

Programmable gateway for the BL67 I/O system
Interface for EtherNet/IP™ (slave)
BL67-PG-EN-IP

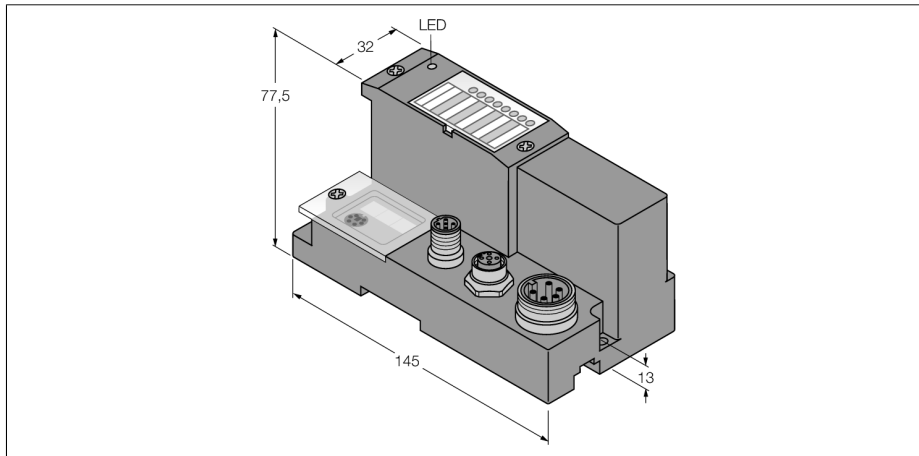

- Programmable acc.to IEC 61131-3 with CoDeSys
- Ethernet and RS232 programming interface
- 512 kbyte program memory
- 32 bit RISC processor
- < 1 ms for 1000 commands
- Protection class IP67
- LEDs for display of supply voltage, group and bus errors
- Interface for EtherNet/IP
- 10/100 Mbps

Type	BL67-PG-EN-IP
Ident-No.	6827246
Supply voltage	24 VDC
Admissible range	18...30 VDC
Rated current from module bus	≤ 600 mA
max. sensor supply I _{sens}	4 A electronically limited current supply
Max. load current I _l	10 A
Voltage supply connection	5-pole male 7/8" connector
Fieldbus transmission rate	10/100 Mbps
Fieldbus addressing	rotary switch, BOOTP, DHCP, IO-ASSISTANT
Fieldbus connection technology	Female connector, M12 x 1, 4-pole, D-coded
Input process image	128 words
Output process image	128 words
PLC data	
Programming	CoDeSys V2.3
Released for CoDeSys version	V 2.3.6.4
Programming languages	IEC 61131-3 (IL, LD, FBD, SFC, ST)
Application tasks	1
Number of POU's	1024
Programming interface	RS232 interface, Ethernet
Processor	RISC, 32 bit
Cycle time	< 1 ms for 1000 IL commands (without I/O cycle)
Program memory	512 kByte
Data memory	512 kByte
Input data	4 kByte
Output data	4 kByte
Non-volatile memory	16 kByte
Service interface	RS232 interface (PS/2 socket)

Without function

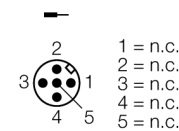

Ethernet

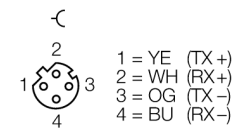

Power supply

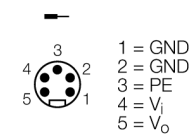

Functional principle

The programmable BL67 gateways can be used as an independent PLC or as a member in a PLC network for fast signal preprocessing.

BL67 gateways are the head component of a BL67 station. The BL67 electronic modules communicate via the internal module bus with the gateway and can be configured independently of the fieldbus protocol.

Programmable gateway for the BL67 I/O system
Interface for EtherNet/IP™ (slave)
BL67-PG-EN-IP

Dimensions (W x L x H)	74x145x77.5mm
Approvals	CE, cULus
Operating temperature	-40...+70 °C
Temperature derating	
> 55 °C Circulating air (Ventilation)	no limitation
> 55 °C Steady ambient air	Isens < 3A, Imb < 1A
Storage temperature	-40 ... +85 °C
Relative humidity	5 to 95% (internal), Level RH-2, no condensation (at 45 °C storage)
Vibration test	acc. to EN 61131
Extended vibration resistance	VN 02-00 and higher
- up to 5 g (at 10 to 150 Hz)	For mounting on DIN rail no drilling according to EN 60715, with end bracket
- up to 20 g (at 10 to 150 Hz)	For mounting on base plate or machinery Therefore every second module has to be mounted with two screws each.
Shock test	acc. to IEC 68-2-27
Drop and topple	acc. to IEC 68-2-31 and free fall to IEC 68-2-32
Electro-magnetic compatibility	acc. to EN 61131-2
Protection class	IP67
DIN rail mounting	yes, Attention: Offset
Direct mounting	Two mounting holes, 6 mm Ø

Programmable gateway for the BL67 I/O system
Interface for EtherNet/IP™ (slave)
BL67-PG-EN-IP

Pin configuration and supply concept

	<p>CANopen (master/slave)</p> <p>The CoDeSys programmable gateways can also be operated as CANopen master or as CANopen slave. Both functions are stored in the library and can be loaded to the gateway together with the CoDeSys application.</p> <p>Connected CANopen subscribers are not supplied by the BL67 system. External power supply is required.</p>	<p>Pin assignment</p> <ul style="list-style-type: none"> 1 = Shield 2 = FD (n.c.) 3 = BK (V₋) 4 = WH (CAN H) 5 = BU (CAN L)
	<p>EtherNet/IP™ slave</p> <p>The M12-D coded Ethernet port is used as interface for configuration and fieldbus communication. The gateway can be operated as a slave at Plus or PC based systems with EtherNet/IP™ scanner (master).</p>	<p>Pin assignment</p> <ul style="list-style-type: none"> 1 = YE (TX +) 2 = WH (RX +) 3 = OG (TX -) 4 = BU (RX -)
	<p>Power supply</p> <p>Double-tuned power supply of the BL67 system.</p> <p>System power supply V_i</p> <p>V_i is for the internal system supply at the backplane bus ($V_{MB(5V)}$) and for the 4A short-circuit limited sensor supply (V_{sens}).</p> <p>Load voltage V_o</p> <p>V_o for output supply, limited to max. 10A.</p>	<p>Pin assignment</p> <ul style="list-style-type: none"> 1 = GND 2 = GND 3 = PE 4 = V_i 5 = V_o <p>voltage supply</p> <p>The diagram shows a dashed line separating the System supply (5V) and Field supply (24V) sections. It includes labels for VMB (5V), IMB (5V), VMB (24V), IMB (24V), a 4A current limit, and output terminals for I_{sens} and I_o. Input terminals are labeled V_i and V_o.</p>

Programmable gateway for the BL67 I/O system
Interface for EtherNet/IP™ (slave)
BL67-PG-EN-IP

LED functions

LED	Color	Status	Description
IO		OFF	No power supply
	GREEN	ON	Station OK
	GREEN	FLASHING (1Hz)	Station in force mode of the I/O-ASSISTANT
	GREEN	FLASHING (4 Hz)	The max. admissible number of modules connected to the gateway is exceeded.
	RED	ON	Insufficient power supply
	RED	FLASHING (1Hz)	The current station configuration does not comply with the configured module list.
	RED	FLASHING (4 Hz)	No module bus communication.
	RED/GREEN	FLASHING (1Hz)	The current and configured module list do not match but the data exchange proceeds as normal.
GW		OFF	No power supply of the CPU.
	GREEN	ON	Firmware active, gateway ready
	GREEN	FLASHING (1Hz)	Firmware inactive.
	GREEN	FLASHING (4 Hz)	Firmware active, gateway hardware error.
	RED	ON	CPU not ready, Vcc too low. Causes of failure: - Too many modules at the gateway - Short circuit in one of the modules - Defective gateway
RUN/STOP		OFF	PG STOP, no application loaded.
	GREEN	FLASHING (1Hz)	PG STOP, CoDeSys application loaded.
	GREEN	ON	PG in RUN, CoDeSys application in process.
Vcc	GREEN	ON	CPU and module bus OK
		OFF	No supply of CPU or short-circuit of the module bus supply.
Vo	GREEN	ON	Supply of outputs OK
	GREEN	FLASHING (1Hz)	Undervoltage Vo; system running.
	GREEN	FLASHING (4 Hz)	Undervoltage Vo; system running.
		OFF	No power supply.
Vi	GREEN	ON	Sensor and system supply OK.
	GREEN	FLASHING (1Hz)	Undervoltage Vi; system running.
	GREEN	FLASHING (4 Hz)	Undervoltage Vi; system running.
	RED	ON	Short-circuit or overload at the sensor supply Vsens.
		OFF	No power supply.
LNK/ACT	GREEN	ON	Link established, 100 Mbps
	GREEN	FLASHING	Ethernet traffic with 100 Mbps
	YELLOW	ON	Link established, 10 Mbps
	YELLOW	FLASHING	Ethernet traffic with 10 Mbps
		OFF	no Ethernet link.
MS	GREEN	ON	An EtherNet/IP™ scanner (master) has established an Ethernet connection to the gateway.
	GREEN	FLASHING	Gateway ready, EtherNet/IP™ connection inactive.
	RED	ON	Gateway error.
	RED	FLASHING	DHCP/BootP search for settings.