

Programmable gateway for the BL67 I/O system
Interface for MODBUS TCP (Slave)
BL67-PG-EN

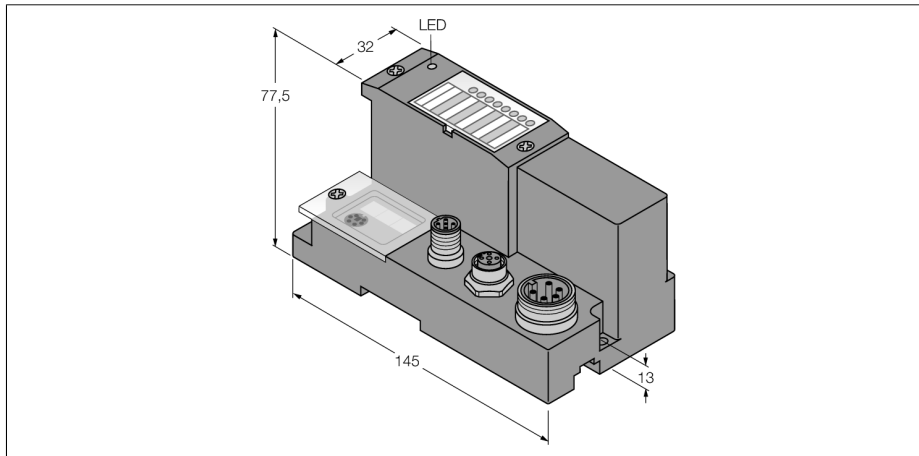

- Programmable acc.to IEC 61131-3 with CoDeSys
- Ethernet and RS232 programming interface
- 512 kbyte program memory
- 32 bit RISC processor
- < 1 ms for 1000 commands
- Protection class IP67
- LEDs for display of supply voltage, group and bus errors
- Interface for MODBUS TCP
- 10/100 Mbps

Type	BL67-PG-EN
Ident-No.	6827241
Supply voltage	24 VDC
Admissible range	18...30 VDC
Rated current from module bus	≤ 600 mA
max. sensor supply I_{sens}	4 A electronically limited current supply
Max. load current I_L	10 A
Fieldbus transmission rate	10/100 Mbps
Fieldbus addressing	rotary switch, BOOTP, DHCP, IO-ASSISTANT
Fieldbus connection technology	Female connector, M12 x 1, 4-pole, D-coded
Input process image	1024 register
Output process image	1024 register
PLC data	
Programming	CoDeSys V2.3
Released for CoDeSys version	V 2.3.6.4
Programming languages	IEC 61131-3 (IL, LD, FBD, SFC, ST)
Application tasks	1
Number of POU's	1024
Programming interface	RS232 interface, Ethernet
Processor	RISC, 32 bit
Cycle time	< 1 ms for 1000 IL commands (without I/O cycle)
Program memory	512 kByte
Data memory	512 kByte
Input data	4 kByte
Output data	4 kByte
Non-volatile memory	16 kByte
Service interface	RS232 interface (PS/2 socket)

Functional principle

The programmable BL67 gateways can be used as an independent PLC or as a member in a PLC network for fast signal preprocessing.

BL67 gateways are the head component of a BL67 station. The BL67 electronic modules communicate via the internal module bus with the gateway and can be configured independently of the fieldbus protocol.

Programmable gateway for the BL67 I/O system

Interface for MODBUS TCP (Slave)

BL67-PG-EN

Dimensions (W x L x H)	74x145x77.5mm
Approvals	CE, cULus
Operating temperature	-40...+70 °C
Temperature derating	
> 55 °C Circulating air (Ventilation)	no limitation
> 55 °C Steady ambient air	Isens < 3A, Imb < 1A
Storage temperature	-40 ... +85 °C
Relative humidity	5 to 95% (internal), Level RH-2, no condensation (at 45 °C storage)
Vibration test	acc. to EN 61131
Extended vibration resistance	VN 02-00 and higher
- up to 5 g (at 10 to 150 Hz)	For mounting on DIN rail no drilling according to EN 60715, with end bracket
- up to 20 g (at 10 to 150 Hz)	For mounting on base plate or machinery Therefore every second module has to be mounted with two screws each.
Shock test	acc. to IEC 68-2-27
Drop and topple	acc. to IEC 68-2-31 and free fall to IEC 68-2-32
Electro-magnetic compatibility	acc. to EN 61131-2
Protection class	IP67
DIN rail mounting	yes, Attention: Offset
Direct mounting	Two mounting holes, 6 mm Ø

Programmable gateway for the BL67 I/O system
Interface for MODBUS TCP (Slave)
BL67-PG-EN

Pin configuration and supply concept

	<p>CANopen (master/slave)</p> <p>The CoDeSys programmable gateways can also be operated as CANopen master or as CANopen slave. Both functions are stored in the library and can be loaded to the gateway together with the CoDeSys application.</p> <p>Connected CANopen subscribers are not supplied by the BL67 system. External power supply is required.</p>	<p>Pin assignment</p> <ul style="list-style-type: none"> 1 = Shield 2 = FD (n.c.) 3 = BK (V₋) 4 = WH (CAN H) 5 = BU (CAN L)
	<p>Modbus TCP (slave)</p> <p>The M12 D-coded Ethernet port is used as interface for programming, configuration and fieldbus communication. The gateway can be operated as a slave at PLCs or PC based systems with Ethernet Modbus TCP master or as a driver.</p>	<p>Pin assignment</p> <ul style="list-style-type: none"> 1 = YE (TX +) 2 = WH (RX +) 3 = OG (TX -) 4 = BU (RX -)
	<p>Power supply</p> <p>Double-tuned power supply of the BL67 system.</p> <p>System power supply V_i</p> <p>V_i is for the internal system supply at the rear panel bus (V_{MB(5V)}) and for the 4A short-circuit limited sensor supply (V_{sens}).</p> <p>Load voltage V_o</p> <p>V_o for output supply, limited to max. 10A.</p>	<p>Pin assignment</p> <ul style="list-style-type: none"> 1 = GND 2 = GND 3 = PE 4 = V_i 5 = V_o <p>voltage supply</p> <p>The diagram shows two supply rails: System supply and Field supply. The System supply rail contains VMB (5 V) and IMB (5 V) terminals. The Field supply rail contains VMB (24 V) and IMB (24 V) terminals. A 4 A current limit is indicated between the field supply rails. The output supply V_o is connected to the field supply rail, and the sensor supply V_{sens} is connected to the field supply rail. The input supply V_i is connected to the field supply rail.</p>

Programmable gateway for the BL67 I/O system
Interface for MODBUS TCP (Slave)
BL67-PG-EN

TURCK

Industrial
Automation

Accessories

Type code	Ident-No.	Description	Dimension drawing
RSSD-RSSD-441-6M/ S2174	6914219	Ethernet cable, M12 straight male connector to M12 male connector, 6 m	
RSSD-RJ45-441-2M/ S2174	6915781	Ethernet cable, M12 straight male connector to RJ45 male connector, 2 m	
RKM52-6M	6914145	Power supply cable, 7/8 straight with open cable end, 6 m	
RSM-2RKM50	6914950	T-piece for power supply, 7/8", 5-pole, 9A nominal current	