

BL20 electronic module
RS232 interface
BL20-1RS232

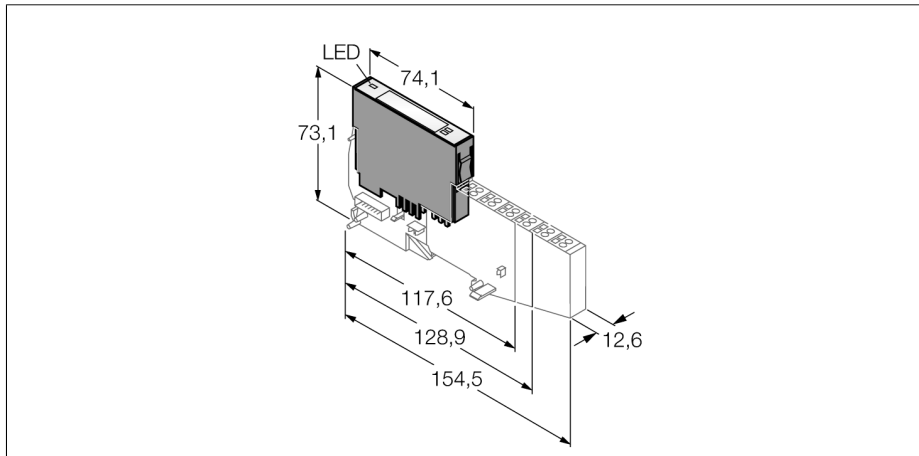

- Fieldbus and connection technology independent
- Protection class IP20
- LEDs indicate status and diagnostic
- Electronics galvanically separated from the field level via optocouplers
- Transmission of serial data via RS232 interface
- For connection of different devices, such as printers, light screens or bar code scanners

Functional principle

BL20 electronic modules are plugged into the purely passive base modules which are used for connection of field devices. Maintenance is significantly facilitated due to separation of the connection level from the module electronics. Furthermore flexibility is enhanced because the base modules provide a choice of tension spring or screw connection technology.

The electronic modules are completely independent of the type of higher level field bus through the use of gateways.

Type	BL20-1RS232
Ident-No.	6827169
Number of channels	
Rated voltage from the supply terminal	24 VDC
Supply voltage	24 VDC
Rated current from field supply	≤ 25 mA
Rated current from module bus	≤ 140 mA
Power loss, typical	≤ 1 W
Inputs / Outputs	
Transmission level active (U RS1)	-15 to -3 VDC
Transmission level inactive (URSO)	3 to 15 VDC
Common-mode range (UGL)	-7 to 12 VDC
Transmission signals	RxD, TxD, RTS, CTS
Data buffer received / sent	128/ 64Byte
Connection type	full duplex
Transmission rate	300 to 115200 bps
Parameter	transmission rate, diagnostics, data bits, stop bits, XON - character, XOFF - character, parity, flow control
Cable length	15m
Electrical isolation	isolation of electronics and field level via optocouplers
Connection technology	
	Screw, tension spring
Number of diagnostics bytes	
Number of diagnostics bytes	1
Number of parameter bytes	4
Dimensions (W x L x H)	
Approvals	12.6x74.1x55.4mm
Operating temperature	CE, cULus, zone2, ClassI,div.2.
Storage temperature	0 ... +55 °C
Relative humidity	-25 ... +85 °C
	5 to 95% (internal), Level RH-2, no condensation (at 45 °C storage)
Vibration test	acc. to EN 61131
Shock test	acc. to IEC 68-2-27
Drop and topple	acc. to IEC 68-2-31 and free fall to IEC 68-2-32
Electro-magnetic compatibility	acc. to EN 50,082-2
Protection class	IP20

BL20 electronic module
RS232 interface
BL20-1RS232

Compatible base modules

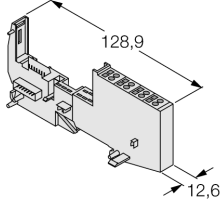
Dimension drawing	Type	Pin configuration
	<p>BL20-S4T-SBBS 6827046 tension spring connection</p> <p>BL20-S4S-SBBS 6827047 screw connection</p>	<p>Wiring diagram</p> 