

LED Diffused On-Axis Lights (75 mm)

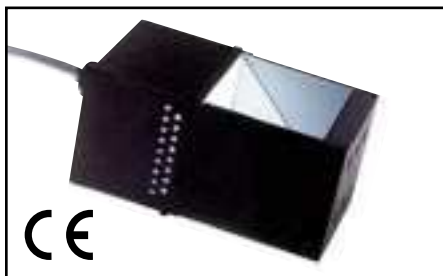

Features

- Diffused on-axis illumination provides uniform lighting for specular surfaces
- 75 mm x 75 mm light aperture
- The suggested field of view is 38 mm x 38 mm and the suggested standoff is 25 mm
- Choose white, blue, or red LED models
- Black anodized aluminum housing

Models

Models	Illumination Type	Color	Cable	Supply Voltage	Supply Current	Connections
LEDW075N [†]	Continuous diffused light	White 6500 K	0.5 m (18") terminated with 9-pin D-sub connector (male pins)	12V dc $\pm 10\%$ with voltage regulation of $\pm 1\%$	1.05 A max.	12V dc models: Pin 1 = +V fan Pin 2 = dc common fan Pin 3 = dc common Pin 4 = +V
LEDB075N [†]		Blue 470 nm				
LEDRO75N [†]		Visible Red 640 nm				
LEDRO75N-H [†]	Continuous diffused light, high output	Red 660 nm			1.0 mA max.	Power supply model PSA-12(E) or PS2V-12(E) is recommended (see other side)
LEDW075N-S [†]	Strobed diffused light	White 6500 K	1.8 m (6') terminated with 9-pin D-sub connector (male pins)	24V dc $\pm 10\%$ with voltage regulation of $\pm 1\%$	9.6 A max.	Pin 4 = +V Pin 1 = dc common
LEDRO75N-S [†]		Red 640 nm				

[†] These models are not stocked and are non-returnable.

Useful Life	White and blue models: 50,000 hours; Red models: 60,000 hours. Note: actual useful life of strobed lights depends on duty cycle
Environmental Rating	IEC IP20; NEMA 1
Operating Conditions	Temperature: 0° to +40°C (+32° to 104°F) Maximum relative humidity: 95% at 40°C (non-condensing)

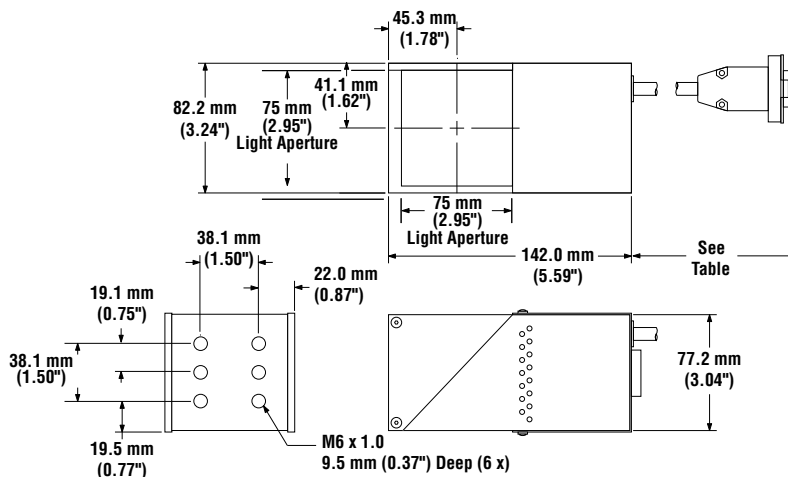

LED Diffused On-Axis Lights (75 mm)

Accessories

Continuous Power Supplies

Models	Input	Input Cord	Output	Output Cable	Used with
PSA-12	100-250V ac 50/60 Hz	North America (NEMA 5-15)	12V dc $\pm 5\%$ with voltage regulation of $\pm 1\%$ 3.5 A max.	1.8 m (6') Terminated with 9-pin D- sub connector (female pins)	Continuous types: LEDW075N LEDB075N LEDRO75N LEDRO75N-H
PSA-12E		Cont. Europe (Schuko CEE 7)			
PSC-24 [†]	100-250V ac 50/60 Hz	North America (NEMA 5-15)	24V dc $\pm 5\%$ with voltage regulation of $\pm 1\%$ 2.2 A max.	1.8 m (6') 2-wire Unterminated	SCM Strobe Control Module (see below)
PSC-24E [†]		Cont. Europe (Schuko CEE 7)			



Variable Power Supplies (see data sheet p/n 67449)

Models	Input	Input Cord	Output	Output Cable	Used with
PS2V-12 [†]	100-140V ac 60 Hz	North America (NEMA 5-15)	2-channels 6 - 12V dc	1.8 m (6') Terminated with 9-pin D-sub connector (female pins)	Continuous types: LEDW075N LEDB075N LEDRO75N LEDRO75N-H
PS2V-12E [†]	200-250V ac 50 Hz	Cont. Europe (Schuko CEE 7)	2 A max. per channel		



Strobe Control Module (see data sheet p/n 67448)

Models	Input	Trigger Input	Output	Output Pulse Range	Used with
SCM [†]	24V dc $\pm 5\%$ 2 A max.	5 - 12V dc pulse rising or falling (switch selectable) 10 mA max.	2-channels 24V dc $\pm 5\%$	5 to 1,300 microseconds	Strobed types: LEDW075N-S LEDRO75N-S
(Use Power Supply PSC-24 or PSC-24E)			9 A nominal per channel @ 60 Hz		



Extension Cables

Models	Length	Configuration	Used with
DB906 [†]	1.8 m (6')	Terminated both ends with 9-pin D-sub connector, for continuous lights (one end male pins and opposite end female pins)	Continuous types: LEDW075N LEDB075N LEDRO75N LEDRO75N-H
DB910 [†]	3.0 m (10')		
DB9Y [†]	1.8 m (6')	Y cable for powering 2 lights from one supply, for continuous lights	
DB906S [†]	1.8 m (6')	Terminated both ends with 9-pin D-sub connector, for strobed lights (one end male pins and opposite end female pins)	Strobed types: LEDW075N-S LEDRO75N-S
DB910S [†]	3.0 m (10')		
DB9YS [†]	1.8 m (6')	Y cable for powering 2 lights from one supply, for strobed lights	

[†] These models are not stocked and are non-returnable.



WARRANTY: Banner Engineering Corp. warrants its products to be free from defects for one year. Banner Engineering Corp. will repair or replace, free of charge, any product of its manufacture found to be defective at the time it is returned to the factory during the warranty period. This warranty does not cover damage or liability for the improper application of Banner products. This warranty is in lieu of any other warranty either expressed or implied.

P/N 67439 rev. A

Banner Engineering Corp., 9714 Tenth Ave. No., Mpls., MN 55441 • Ph: 763.544.3164 • www.bannerengineering.com • Email: sensors@bannerengineering.com