

# LED..R..M Series Ring Lights



LED Ring Lights (in two sizes) for use with PresencePLUS® P4 sensor



- Low-cost ring lights for PresencePLUS® P4 sensor. See Banner's Web site ([www.bannerengineering.com/iknowlighting](http://www.bannerengineering.com/iknowlighting)) for a complete lighting tutorial.
- Solid-state LED matrix; select continuous or strobed operation via sensor software.
- Direct connection to PresencePLUS P4 (if sensor is powered by 24V dc)
- Mounts directly to PresencePLUS P4 sensor using included hardware

## Models

PresencePLUS Pro and ProII Sensor Models					
Model*		Color	Ambient Light Filter Kit	Polarizing Filter Kit	
62 x 62 mm	80 x 80 mm			62 x 62 mm	80 x 80 mm
LEDIR62X62M	LEDIR80X80M	Infrared, 940 nm	FLTI	—	—
LEDRR62X62M	LEDRR80X80M	Visible Red, 630 nm	FLTR (included with LEDRRPFK)	LEDRRPFKS	LEDRRPFK
LEDWR62X62M	LEDWR80X80M	White, All Visible	FLTB or FLTG		
LEDBR62X62M	LEDBR80X80M	Blue, 464 to 475 nm	FLTB		
LEDGR62X62M	LEDGR80X80M	Green, 520 to 540 nm	FLTG		

\*For 9 m (30') integral cable, add suffix "W/30" to the model number (e.g., LEDIR80X80W W/30).

PresencePLUS Mini Pro Sensor Models				
Models	Color	Ambient Light Filter Kit	Polarizing Filter Kit	
62 x 62 mm			62 x 62 mm	80 x 80 mm
LEDIRM62X62M	Infrared, 940 nm	FLTI	—	—
LEDRRM62X62M	Visible Red, 630 nm	FLTR (included with LEDRRPFK)	LEDRRPFKS	LEDRRPFK
LEDWRM62X62M	White, All Visible	FLTB or FLTG		
LEDBRM62X62M	Blue, 464 to 475 nm	FLTB		
LEDGRM62X62M	Green, 520 to 540 nm	FLTG		

\*For 9 m (30') integral cable, add suffix "W/30" to the model number (e.g., LEDIR80X80W W/30).



## Specifications

### Supply Voltage and Current

Voltage supplied by *PresencePLUS* P4 sensors, if operating at 24V dc (see sensor manual).

**62 x 62 Models: Infrared** — 24V dc @ 100 mA max.

**80 x 80 Models:** 24V dc @ 250 mA max.

**All other colors** — 24V dc @ 130 mA max.

### Connections

300 mm (12") attached pigtail with 3-wire, 8 mm male Pico-style connector

### Construction

Low-carbon steel with black zinc plating, acrylic window

### Light Source

LED, see Models table above for wave lengths

### Illumination

High-intensity ring light

### Useful Life

10,000 hours (LED ON time). When operated within specifications, output will decrease less than 30% after 10,000 hours and less than 50% (less than 40% for red and IR models) after 20,000 hours.

### Operating Conditions

Temperature: 0° to +50° C (+32° to 122° F)

Relative humidity: 90% at 50° C (non-condensing) max.

**Cleaning Instructions.** Regularly remove any dust, dirt, or fingerprints from the light source.

1. Blow off dust using anti-static compressed air.
2. If necessary, use a lens cloth and lens cleaner or window cleaner to wipe off remaining debris. Do not use any other chemicals for cleaning.

## Dimensions

### 62 x 62 mm Models

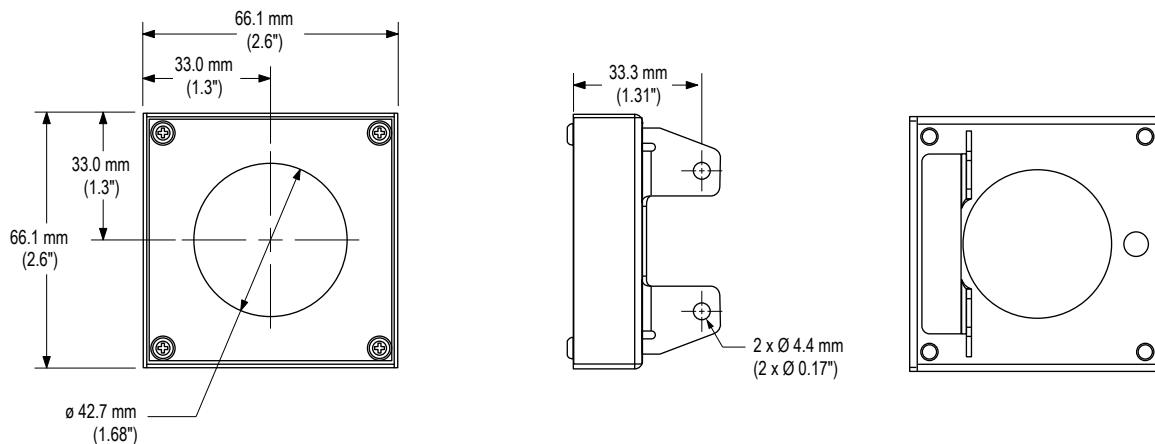

### 80 x 80 mm Models

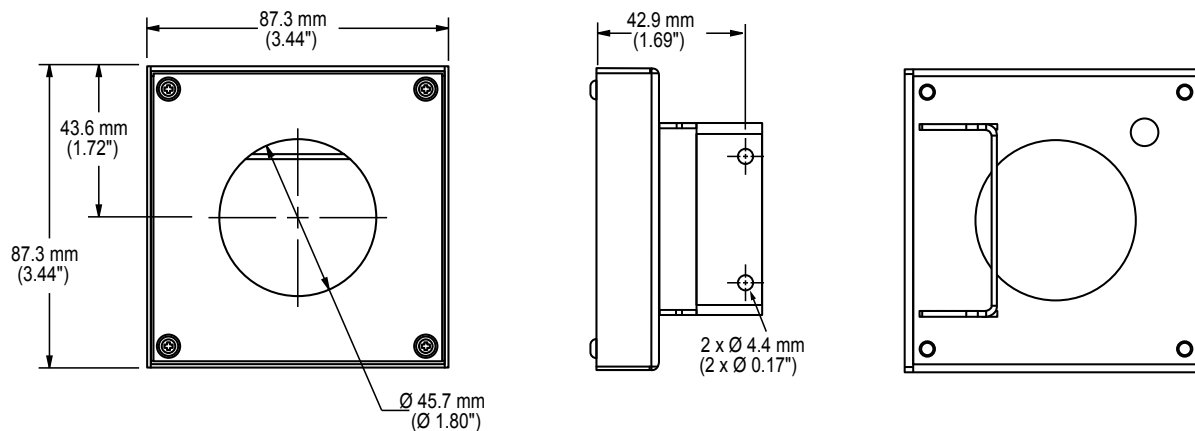

## Installing the Ring Light

The ring light bracket attaches to the top of the *PresencePLUS* P4 lens block, using the hardware kit provided.



**NOTE:** Before installing this light it is recommended that an ambient light filter be installed behind the lens. The filter improves image quality by reducing unwanted ambient light.

### Sensing Shiny Surfaces

To eliminate direct reflections without using polarizing filters, angle the sensor approximately 15° (or more) from perpendicular to a shiny surface.

### Polarizing Kit

If it is necessary to mount the camera at a 90° angle to a shiny surface, the polarizing filter kit provides filters for both the LED ring light and sensor to reduce the negative effects of strong, direct light reflections. The red filter kit (FLTR) is included with the polarizing kit. When light colors other than red are used, discard the red filter in the polarizing kit and use the proper filter (see Models tables). The polarizing filters reduce the amount of light returned to the sensor.

## Banner Engineering Corp Limited Warranty

Banner Engineering Corp. warrants its products to be free from defects in material and workmanship for one year following the date of shipment. Banner Engineering Corp. will repair or replace, free of charge, any product of its manufacture which, at the time it is returned to the factory, is found to have been defective during the warranty period. This warranty does not cover damage or liability for misuse, abuse, or the improper application or installation of the Banner product.

**THIS LIMITED WARRANTY IS EXCLUSIVE AND IN LIEU OF ALL OTHER WARRANTIES WHETHER EXPRESS OR IMPLIED (INCLUDING, WITHOUT LIMITATION, ANY WARRANTY OF MERCHANTABILITY OR FITNESS FOR A PARTICULAR PURPOSE), AND WHETHER ARISING UNDER COURSE OF PERFORMANCE, COURSE OF DEALING OR TRADE USAGE.**

This Warranty is exclusive and limited to repair or, at the discretion of Banner Engineering Corp., replacement. **IN NO EVENT SHALL BANNER ENGINEERING CORP. BE LIABLE TO BUYER OR ANY OTHER PERSON OR ENTITY FOR ANY EXTRA COSTS, EXPENSES, LOSSES, LOSS OF PROFITS, OR ANY INCIDENTAL, CONSEQUENTIAL OR SPECIAL DAMAGES RESULTING FROM ANY PRODUCT DEFECT OR FROM THE USE OR INABILITY TO USE THE PRODUCT, WHETHER ARISING IN CONTRACT OR WARRANTY, STATUTE, TORT, STRICT LIABILITY, NEGLIGENCE, OR OTHERWISE.**

Banner Engineering Corp. reserves the right to change, modify or improve the design of the product without assuming any obligations or liabilities relating to any product previously manufactured by Banner Engineering Corp.