

Models

Clear Glass	Clear Acrylic	Clear Diffusing Acrylic	White Diffusing Acrylic	For Use with Linear Array Models
LEDLA290SW-G	LEDLA290SW-P	LEDLA290SCDW-P	LEDLA290SVDW-P	LED..LA290S..
LEDLA580SW-G	LEDLA580SW-P	LEDLA580SCDW-P	LEDLA580SVDW-P	LED..LA580S..

Installing the Replacement Window

1. Remove all the screws and the bezel on the light (Figure 1).
2. Remove the existing window.

NOTE: It is not required to remove o-ring unless replacing. If necessary, remove any debris on o-ring or surrounding area during window replacement. Replacement o-rings are available through Banner for damaged o-rings; see models below.

O-Ring Model	Linear Array Size	Linear Array Housing
LEDLA290SO	290 mm	Nickel-plated aluminum
LEDLA580SO	580 mm	
LEDLA290SSO	290 mm	Stainless steel
LEDLA580SSO	580 mm	

3. Remove the protective coverings from both sides of the window.

NOTE: Take care not to touch the inside surface of the window; hold it by the edges only. If necessary, clean the window using lens or window cleaner. For Diffused Window models, place "frosted" (diffused) side of window against o-ring.

4. Place the window onto the light. Secure with the screws and bezel. Tighten screws so that there is no gap between the bezel and the light housing.

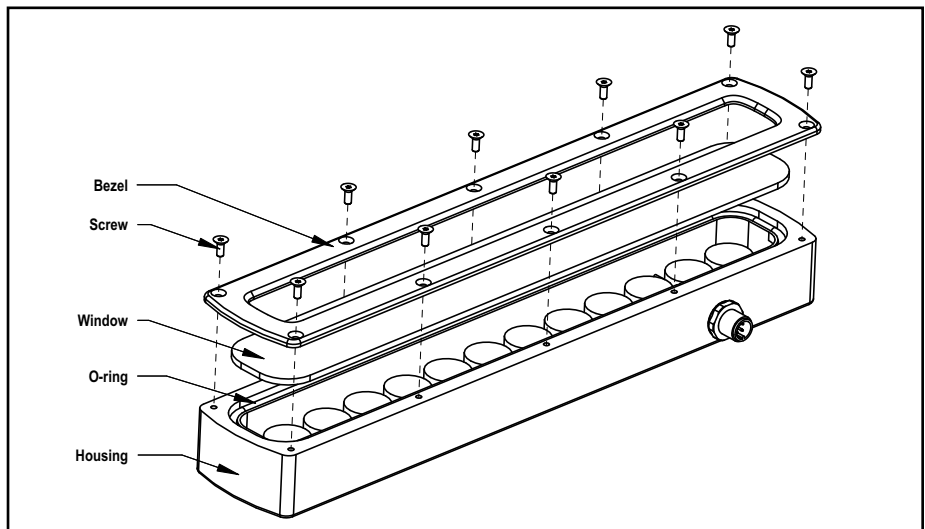

Figure 1. Installing the replacement window on the light