

# Hinge Wing Safety Interlock Switches



SI-HG80 Series Safety Interlock Switches encapsulated in a load-bearing hinge



- Safety switch is integrated and encapsulated into a load-bearing hinge, providing a high degree of protection from intentional defeat
- Identical in appearance to non-switching blank hinge (see [Accessories](#) on page 6)
- Switch components concealed inside the hinge are protected from mechanical impact, providing superior performance to actuator-activated safety switches; rated IEC IP67
- Hinge operates to a full 180° range of motion; safety switching point (guard-closed position) is adjustable over the full 0–180° operating range
- Hinge can support an axial load of 750 N and more than 1,000 N in radial direction
- When properly interfaced or used with an appropriate controller, two SI-HG80D.. switches can achieve safety category 4, per ISO 13849 (EN 954-1)
- Robust zinc die-cast housing is corrosion resistant
- Typical applications include:
  - Hinged covers and guards to machines
  - Hinged doors and gates in safety fencing systems
  - Modular aluminum framing

Inline QD Fitting    Right-angle QD Fitting

Model	QD Connection	Contact Configuration (Closed State)	Contact Configuration (Open State)	Switching Diagram
SI-HG80DQD	Inline QD Fitting			
SI-HG80DQDR	Right-angle QD Fitting			

Note: Terminal #3 is non-safety.

### Switching Diagram Key



## Important Information Regarding the Use of Safety Switches

In the United States, the functions that Banner safety switches are intended to perform are regulated by the Occupational Safety and Health Administration (OSHA). Whether or not any particular safety switch installation meets all applicable OSHA requirements depends upon factors that are beyond the control of Banner Engineering Corp. These factors include the details of how the safety switches are applied, installed, wired, operated, and maintained.

Banner Engineering Corp. has attempted to provide complete application, installation, operation, and maintenance instructions. This information is found in the instruction manual packaged with each safety switch. In addition, we suggest that any questions regarding the use or installation of safety switches be directed to the factory applications department at the telephone numbers or address shown below.



Banner Engineering Corp. recommends that safety switches be applied according to the guidelines set forth in international (ISO/IEC) standards listed below. Specifically, Banner Engineering Corp. recommends application of these safety switches in a configuration which meets safety category 4, per ISO 13849 (EN954-1).

In addition, the user of Banner safety switches has the responsibility to ensure that all local, state, and national laws, rules, codes, and regulations relating to the use of Banner safety switches in any particular application are satisfied. Extreme care is urged that all legal requirements have been met and that all installations and maintenance instructions are followed.

Application Assistance  
Toll Free: 1-888-3-SENSOR (1-888-373-6767)  
Email: sensors@bannerengineering.com  
9714 Tenth Avenue North  
Minneapolis, MN 55441

### U.S. Regulations Applicable to Use of Banner Safety Switches

OSHA Code of Federal Regulations: Title 29, Parts 1900 to 1910

Available from: Superintendent of Documents, Government Printing Office, P.O. Box 371954, Pittsburgh, PA 15250-7954, Tel: 202-512-1800

### U.S. Standards Applicable to Use of Banner Safety Switches

ANSI B11 Standards for Machine Tools Safety

Contact: Safety Director, AMT – The Association for Manufacturing Technology, 7901 Westpark Drive, McLean, VA 22102, Tel.: 703-893-2900

### Applicable European and International Standards

ISO/TR 12100-1 (EN 292-1 & -2) Safety of Machinery – Basic Concepts, General Principles for Design

ISO 13852 (EN 294) Safety of Machinery—Safety Distances to Prevent Danger Zones Being Reached by the Upper Limbs

ISO 13853 (EN 811) Safety of Machinery—Safety Distances to Prevent Danger Zones Being Reached by the Lower Limbs

ISO 13849-1 (EN 954-1) Safety-Related Parts of Control Systems

ISO 13855 (EN 999) The Positioning of Protective Equipment in Respect to Approach Speeds of Parts of the Human Body

ISO 14119 (EN 1088) Interlocking Devices Associated with Guards – Principles for Design and Selection

IEC 60204-1 Electrical Equipment of Machines Part 1: General Requirements

IEC 60947-5-1 Low Voltage Switchgear – Electromechanical Control Circuit Devices

Contact: Global Engineering Documents, 15 Inverness Way East, Englewood, CO 80112-5704, Tel.: 800-854- 7179

## Mechanical Installation



#### WARNING: Hazard Point

**It must not be possible for personnel to reach any hazard point through an opened guard (or any opening) before hazardous machine motion has completely stopped.**

Please reference OSHA CFR 1910.217 and ANSI B11 standards for information on determining safety distances and safe opening sizes for your guarding devices.

All mounting hardware is supplied by the user. Fasteners must be of sufficient strength to guard against breakage. Use of permanent fasteners or locking hardware is recommended to prevent loosening or displacement of the actuator and the switch body. The mounting holes in the switch body and the actuator accept M6 screws (see [Dimensions](#) on page 5).

Ensure that excessive force is not exerted by the weight and swing of the guard, gate, or door (see [Specifications](#) on page 5).

Position blank hinges (if used) and the hinge switch(es) on the guard or gate while it is in its fully closed and latched position. Verify that the axis of rotation is identical for all hinges used. (Typically, this can be accomplished by using a straight edge along the long flat edge to ensure the switch bodies are parallel.) After the mounting hardware is secure, check the rotation of the guard or gate for misalignment and binding.

NOTE: A safety switch must be installed in a manner that discourages tampering or defeat.



**CAUTION:  
End Stops.**

Do not use the switch as an end stop. The operating angle of the switch must be limited by outer end stops.

## Setting the Switch Point



**CAUTION:  
Remove Set Screw Head.**

Shear off the hexagonal head of the set screw after it is set, and before using the switch. If not, the safe activation of the switch can not be ensured.



**Figure 1. Hinge switch with set screw head in place**

1. Ensure the hinge switches (and blind hinges, if used) are properly mounted and the guard or gate swings freely throughout its range of motion without binding. If binding is noticed, repeat the mechanical installation procedures.
2. Place the guard in its closed and latched position.  
After the switch point is set, it cannot be changed. Before proceeding, verify the installation is correct and the resulting switching action is what is expected.
3. Tighten the hexagonal set screw head with a 13 mm open-ended wrench (rotate clockwise when switch is mounted vertically and the nut is on top). See [Figure 1. Hinge switch with set screw head in place](#) on page 3.
4. Continue tightening until the set screw head shears completely off the switch. When the screw head shears off, the switch point is set.

## Electrical Installation



**CAUTION: Electrical Installation**

**Two safety switches must be used for each interlock guard to achieve control reliability or Safety Category 4 (per ISO 13849-1, EN 954-1) of a machine stop circuit. Use of only one safety switch per interlock guard is not recommended.**

In addition, normally-closed safety contacts from each of the two safety switches should be connected to the two separate inputs of a 2-channel safety module or safety interface. This is required to provide monitoring for safety switch contact failure, and to provide the necessary reset routine, as required by IEC 60204-1 and NFPA 79 machine safety standards.



### WARNING: Series Connection of Safety Interlock Switches

Monitoring multiple guards with a series connection of safety interlock switches may result in a failure being masked or not detected at all. When such a configuration is used, periodic checks must be performed regularly to verify proper operation. All failures must be immediately corrected ( e.g. immediately replacing a failed switch), or the loss of the safety stop signal or an inappropriate reset could lead to serious injury or death.

As shown, a normally-closed safety contact (i.e., a safety contact that is closed when the actuator is engaged) from each of two safety switches per interlock guard must connect to a 2-channel safety module or safety interface to achieve a control reliable interface to the master stop control elements of a machine. Examples of appropriate safety modules include 2-channel emergency stop (E-stop) safety modules and gate monitor safety modules.

Two functions of the safety module or safety interface are to:

1. provide a means of monitoring the contacts of both safety switches for contact failure, and to prevent the machine from restarting if either switch fails; and
2. provide a reset routine after closing the guard and returning the safety switch contacts to their closed position. This prevents the controlled machinery from restarting by simply closing the guard. This necessary reset function is required by ANSI B11 and NFPA 79 machine safety standards.

Use only the positively driven, normally closed safety contact (between pins 1 and 2) from each switch for connection to the safety module. A typical use is to communicate with a process controller. Refer to the installation instructions provided with the safety modules for more information regarding the interface of the safety module to the machine stop control elements.

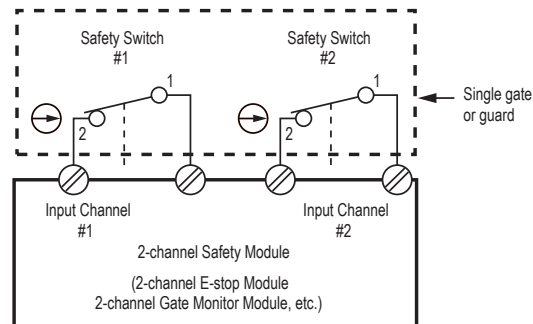

**Figure 2. Hinge Wiring to Safety Module**

Connect two redundant safety switches per interlock guard to an appropriate 2-channel input safety module.

Refer to the installation instructions provided with the safety module for information regarding the interface of the safety module to the machine stop control elements.

## Periodic Checks

A designated person should perform the following safety switch checks at each shift change or machine setup.

A designated person is identified in writing by the employer as being appropriately trained to perform a specified checkout procedure.

1. Check the switch body for damaged or broken parts.
2. Confirm the safety switch is not being used as an end stop.
3. Verify it is not possible to reach any hazard point through an opened guard (or any opening) before hazardous machine motion has completely stopped.
4. Verify the hinge swings freely throughout its total operating range.
5. Tighten any loosened mounting hardware.
6. Check for signs of deterioration or damage.
7. Check for signs of tampering or defeat to the switch or to the wiring interface to the machine.

## Repairs

**Do not attempt any repairs to the Module. It contains no field-replaceable components.** Return it to the factory for warranty repair or replacement by contacting Banner Factory Application Engineering. They will attempt to troubleshoot the system from your description of the problem. If they conclude a component is defective, they will issue a return merchandise authorization (RMA) number for your paperwork and give you the proper shipping address.

**Pack the Module carefully. Damage that occurs in return shipping is not covered by warranty.**



**CAUTION: Abuse of Module After Failure**

If an internal fault has occurred and the Module will not reset, **do not tap, strike, or otherwise attempt to correct the fault by a physical impact to the housing.** An internal relay may have failed in such a manner that its replacement is required.

**If the Module is not immediately replaced or repaired, multiple simultaneous failures may accumulate such that the safety function can not be guaranteed.**

**Specifications**

**Contact Rating**

3A @ 250V ac max., 0.5 A @ 60V dc max.  
 2.5 kV max. transient tolerance  
 NEMA A300 P300

**European Rating**

Utilization categories: AC15 and DC13 (IEC 90497-5-1)  
 Ui = 250V ac  
 Ith = 3A

**Short Circuit Protection**

6 amp Slow Blow, 10 amp Fast Blow. Recommended external fusing or overload protection.

**Wire Connections**

4-pin Micro-style quick-disconnect (QD) fitting. Cables are ordered separately; see Accessories.

**Weight**

0.40 kg (0.88 lb)

**Minimum Switching Speed**

20 operations per minute

**Mechanical Life**

1 million operations

**Force Exerted by Guard per Switch**

Axial: 750 N (165 lbf) max.  
 Radial: 1000 N (220 lbf) max.

**Operating Range**

0° to 180°

**Construction**

Zinc Die-cast (GD-Zn)

**Environmental Rating**

NEMA 4, IEC IP67

**Operating Conditions**

Temperature: -25° to +70° C (-13° to +158° F)

**Application Notes:** To avoid excessive radial stress in applications containing large doors, the hinge switch should be mounted either in pairs of two, or in conjunction with a blank hinge (see page 7).

**Certifications:**



**Dimensions**

**Model SI-HG80DQD**

**Model SI-HG80DQDR**

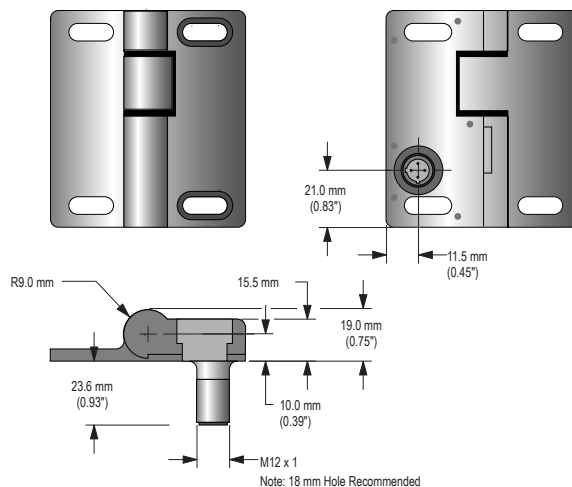
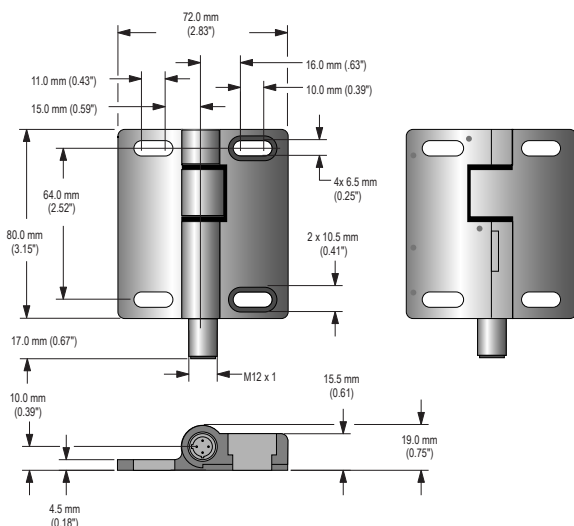

## Accessories

4-Pin Micro-Style Cordsets				
Model	Length	Style	Dimensions	Pinout
MQEAC-406	1.83 m (6 ft)	Straight		<p>1 = Red/Black 2 = Red/White 3 = Red 4 = Green</p>
MQEAC-415	4.57 m (15 ft)			
MQEAC-430	9.14 m (30 ft)			
MQEAC-406RA	1.83 m (6 ft)	Right-Angle		
MQEAC-415RA	4.57 m (15 ft)			
MQEAC-430RA	9.14 m (30 ft)			

Blank Hinge		
Model	Description	Dimensions
SI-HG80A	Same mechanical specifications as SI-HG80 Series Hinge Switches	

## Banner Engineering Corp Limited Warranty

Banner Engineering Corp. warrants its products to be free from defects in material and workmanship for one year following the date of shipment. Banner Engineering Corp. will repair or replace, free of charge, any product of its manufacture which, at the time it is returned to the factory, is found to have been defective during the warranty period. This warranty does not cover damage or liability for misuse, abuse, or the improper application or installation of the Banner product.

**THIS LIMITED WARRANTY IS EXCLUSIVE AND IN LIEU OF ALL OTHER WARRANTIES WHETHER EXPRESS OR IMPLIED (INCLUDING, WITHOUT LIMITATION, ANY WARRANTY OF MERCHANTABILITY OR FITNESS FOR A PARTICULAR PURPOSE), AND WHETHER ARISING UNDER COURSE OF PERFORMANCE, COURSE OF DEALING OR TRADE USAGE.**

This Warranty is exclusive and limited to repair or, at the discretion of Banner Engineering Corp., replacement. **IN NO EVENT SHALL BANNER ENGINEERING CORP. BE LIABLE TO BUYER OR ANY OTHER PERSON OR ENTITY FOR ANY EXTRA COSTS, EXPENSES, LOSSES, LOSS OF PROFITS, OR ANY INCIDENTAL, CONSEQUENTIAL OR SPECIAL DAMAGES RESULTING FROM ANY PRODUCT DEFECT OR FROM THE USE OR INABILITY TO USE THE PRODUCT, WHETHER ARISING IN CONTRACT OR WARRANTY, STATUTE, TORT, STRICT LIABILITY, NEGLIGENCE, OR OTHERWISE.**

Banner Engineering Corp. reserves the right to change, modify or improve the design of the product without assuming any obligations or liabilities relating to any product previously manufactured by Banner Engineering Corp.