





WARNING . . .

Spare actuators must NEVER be used to bypass or otherwise defeat the protective function of a safety switch. To do so may create an unsafe situation which could lead to serious injury or death.



Features

-  Positive opening safety contacts (IEC 60947-5-1) (not dependent upon springs)
-  Insulated device (IEC 60947-5-1)
- Choice of two locking mechanism types:
 - Spring lock with energized solenoid release
 - Energized solenoid lock with spring unlock
- Two solenoid voltages available:
 - 24V ac/dc
 - 24 to 48V dc or 24 to 230V ac
- Choose either of two stainless steel actuator types:
 - Rigid in-line
 - Flexible in-line
- Actuator head rotatable in 90° increments and can be positioned for either horizontal or vertical actuation
- Choice of four switching contact configurations (with actuator engaged):
 - 1 normally-open plus 1 normally-closed
 - 2 normally-closed
 - 2 normally-closed plus 1 normally-open
 - 3 normally-closed

NOTE:  This symbol is used in the switching diagrams to identify the point in actuator travel where the normally closed safety contact is fully open.



Machine Safety Switches – SI-LS42 Series Locking Style Switch



Important Information Regarding the Use of Safety Switches

In the United States, the functions that Banner safety switches are intended to perform are regulated by the Occupational Safety and Health Administration (OSHA). Whether or not any particular safety switch installation meets all applicable OSHA requirements depends upon factors that are beyond the control of Banner Engineering Corp. These factors include the details of how the safety switches are applied, installed, wired, operated, and maintained.

Banner Engineering Corp. has attempted to provide complete application, installation, operation, and maintenance instructions. This information is found in the instruction manual packaged with each safety switch. In addition, we suggest that any questions regarding the use or installation of safety switches be directed to the factory applications department at the telephone numbers or address shown below.

Banner Engineering Corp. recommends that safety switches be applied according to the guidelines set forth in international (ISO/IEC) standards listed below. Specifically, Banner Engineering Corp. recommends application of these safety switches in a configuration which meets safety category 4, per ISO 13849 (EN954-1).

In addition, the user of Banner safety switches has the responsibility to ensure that all local, state, and national laws, rules, codes, and regulations relating to the use of Banner safety switches in any particular application are satisfied. Extreme care is urged that all legal requirements have been met and that all installations and maintenance instructions are followed.

Application Assistance

Toll Free: 1-888-3-SENSOR (1-888-373-6767)
Email: sensors@bannerengineering.com
Address: 9714 Tenth Avenue North
Minneapolis, MN 55441

U.S. Regulations Applicable to Use of Banner Safety Switches

OSHA Code of Federal Regulations: Title 29, Parts 1900 to 1910

Available from: Superintendent of Documents
Government Printing Office
P.O. Box 371954
Pittsburgh, PA 15250-7954
Tel: 202-512-1800

U.S. Standards Applicable to Use of Banner Safety Switches

ANSI B11 Standards for Construction, Care, and Use of Machine Tools"
Available from: Safety Director
AMT—The Association for Manufacturing Technology
7901 Westpark Drive
McLean, VA 22102
Tel: 703-893-2900



Applicable European and International Standards

ISO/TR 12100-1/-2 "Safety of Machinery—Basic Concepts, General Principles for Design"
(EN292-1/-2)
ISO 13852 (EN 294) "Safety of Machinery—Safety Distances to Prevent Danger Zones Being Reached by the Upper Limbs"
ISO 13853 (EN 811) "Safety of Machinery—Safety Distances to Prevent Danger Zones Being Reached by the Lower Limbs"
ISO 13849-1 (EN 954-1) "Safety of Machinery—Safety Related Parts of Control Systems"
ISO 13855 (EN 999) "Safety of Machinery—The Positioning of Protective Equipment in Respect to Approach Speeds of Parts of the Human Body"
ISO 14119 (EN 1088) "Safety of Machinery—Interlocking Devices Associated with Guards—Principles for Design and Selection"
IEC/EN 60204-1 "Safety of Machinery—Electrical Equipment of Machines"
IEC/EN 60947-5-1 "Low Voltage Switchgear—Electromechanical Control Circuit Devices"
Available from: Global Engineering Documents
15 Inverness Way East
Englewood, CO 80112-5704
Phone: 1-800-854-7179
Fax: 303-397-2740

Machine Safety Switches – SI-LS42 Series Locking Style Switch

Models

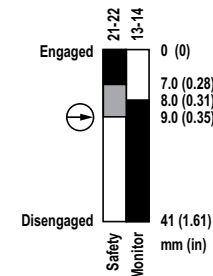
For the following models, the actuator is mechanically locked when it is fully inserted into the actuator head. The actuator is unlocked by applying voltage to the solenoid.

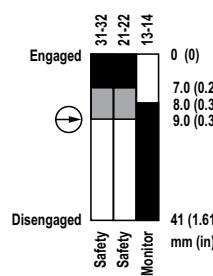
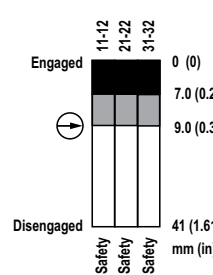
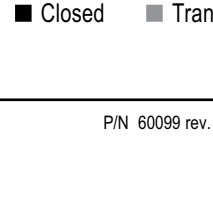
Kit Model†	Solenoid Voltage	Actuator Type†	Interlock Body†	Contact Configuration (Actuator Engaged and Locked)	Contact Configuration (Actuator Unlocked and Removed)	Switching Diagram*
SI-LS42DMSG	24V ac/dc	SI-QM-SSA Rigid In-Line	SI-LS42DSG	Actuator Contacts 21 ○ — ○ 22 13 ○ — ○ 14	Actuator Contacts 21 ○ — ○ 22 13 ○ — ○ 14	
SI-LS42UMSG	24-48V dc 24-230V ac		SI-LS42USG	Solenoid Monitor Contacts 31 ○ — ○ 32 43 ○ — ○ 44 E1 — □ — E2 + — -	Solenoid Monitor Contacts 31 ○ — ○ 32 43 ○ — ○ 44 E1 — □ — E2 + — -	
SI-LS42DMSGF	24V ac/dc	SI-QM-SMFA Flexible In-Line	SI-LS42DSG	Actuator Contacts 11 ○ — ○ 12 21 ○ — ○ 22	Actuator Contacts 11 ○ — ○ 12 21 ○ — ○ 22	
SI-LS42UMSGF	24-48V dc 24-230V ac		SI-LS42USG	Solenoid Monitor Contacts 31 ○ — ○ 32 43 ○ — ○ 44 E1 — □ — E2 + — -	Solenoid Monitor Contacts 31 ○ — ○ 32 43 ○ — ○ 44 E1 — □ — E2 + — -	
SI-LS42DMSH	24V ac/dc	SI-QM-SSA Rigid In-Line	SI-LS42DSH	Actuator Contacts 11 ○ — ○ 12 21 ○ — ○ 22	Actuator Contacts 11 ○ — ○ 12 21 ○ — ○ 22	
SI-LS42UMSH	24-48V dc 24-230V ac		SI-LS42USH	Solenoid Monitor Contacts 31 ○ — ○ 32 43 ○ — ○ 44 E1 — □ — E2 + — -	Solenoid Monitor Contacts 31 ○ — ○ 32 43 ○ — ○ 44 E1 — □ — E2 + — -	
SI-LS42DMSHF	24V ac/dc	SI-QM-SMFA Flexible In-Line	SI-LS42DSH	Actuator Contacts 31 ○ — ○ 32 21 ○ — ○ 22 13 ○ — ○ 14	Actuator Contacts 31 ○ — ○ 32 21 ○ — ○ 22 13 ○ — ○ 14	
SI-LS42UMSHF	24-48V dc 24-230V ac		SI-LS42USH	Solenoid Monitor Contacts 41 ○ — ○ 42 E1 — □ — E2 + — -	Solenoid Monitor Contacts 41 ○ — ○ 42 E1 — □ — E2 + — -	
SI-LS42DMSI	24V ac/dc	SI-QM-SSA Rigid In-Line	SI-LS42DSI	Actuator Contacts 31 ○ — ○ 32 21 ○ — ○ 22 13 ○ — ○ 14	Actuator Contacts 31 ○ — ○ 32 21 ○ — ○ 22 13 ○ — ○ 14	
SI-LS42UMSI	24-48V dc 24-230V ac		SI-LS42USI	Solenoid Monitor Contacts 41 ○ — ○ 42 E1 — □ — E2 + — -	Solenoid Monitor Contacts 41 ○ — ○ 42 E1 — □ — E2 + — -	
SI-LS42DMSIF	24V ac/dc	SI-QM-SMFA Flexible In-Line	SI-LS42DSI	Actuator Contacts 11 ○ — ○ 12 21 ○ — ○ 22 31 ○ — ○ 32	Actuator Contacts 11 ○ — ○ 12 21 ○ — ○ 22 31 ○ — ○ 32	
SI-LS42UMSIF	24-48V dc 24-230V ac		SI-LS42USI	Solenoid Monitor Contacts 41 ○ — ○ 42 E1 — □ — E2 + — -	Solenoid Monitor Contacts 41 ○ — ○ 42 E1 — □ — E2 + — -	
SI-LS42DMSJ	24V ac/dc	SI-QM-SSA Rigid In-Line	SI-LS42DSJ	Actuator Contacts 11 ○ — ○ 12 21 ○ — ○ 22 31 ○ — ○ 32	Actuator Contacts 11 ○ — ○ 12 21 ○ — ○ 22 31 ○ — ○ 32	
SI-LS42DMSJF		SI-QM-SMFA Flexible In-Line		Solenoid Monitor Contacts 41 ○ — ○ 42 E1 — □ — E2 + — -	Solenoid Monitor Contacts 41 ○ — ○ 42 E1 — □ — E2 + — -	

† A kit contains an interlock and actuator. Individual interlock bodies and actuators are for replacement purposes only. See Warning on page 12.

*Contacts: □ Open ■ Closed ▒ Transition

Machine Safety Switches – SI-LS42 Series Locking Style Switch

Models

For the following models, the fully inserted actuator is locked when voltage is applied to the solenoid. The actuator is unlocked when voltage is removed from the solenoid.

Kit Model†	Solenoid Voltage	Actuator Type†	Interlock Body†	Contact Configuration (Actuator Engaged and Locked)	Contact Configuration (Actuator Unlocked and Removed)	Switching Diagram*
SI-LS42DMMG	24V ac/dc	SI-QM-SSA Rigid In-Line	SI-LS42DMG	Actuator Contacts 21 ○ ○ 22 13 ○ ○ 14	Actuator Contacts 21 ○ ○ 22 13 ○ ○ 14	
SI-LS42UMMG	24-48V dc 24-230V ac		SI-LS42UMG	Solenoid Monitor Contacts 31 ○ ○ 32 43 ○ ○ 44 E1- E2 + -	Solenoid Monitor Contacts 31 ○ ○ 32 43 ○ ○ 44 E1- E2 + -	
SI-LS42DMMGF	24V ac/dc	SI-QM-SMFA Flexible In-Line	SI-LS42DMG	Actuator Contacts 11 ○ ○ 12 21 ○ ○ 22	Actuator Contacts 11 ○ ○ 12 21 ○ ○ 22	
SI-LS42UMMGF	24-48V dc 24-230V ac		SI-LS42UMG	Solenoid Monitor Contacts 31 ○ ○ 32 43 ○ ○ 44 E1- E2 + -	Solenoid Monitor Contacts 31 ○ ○ 32 43 ○ ○ 44 E1- E2 + -	
SI-LS42DMMH	24V ac/dc	SI-QM-SSA Rigid In-Line	SI-LS42DMH	Actuator Contacts 11 ○ ○ 12 21 ○ ○ 22	Actuator Contacts 11 ○ ○ 12 21 ○ ○ 22	
SI-LS42UMMH	24-48V dc 24-230V ac		SI-LS42UMH	Solenoid Monitor Contacts 31 ○ ○ 32 43 ○ ○ 44 E1- E2 + -	Solenoid Monitor Contacts 31 ○ ○ 32 43 ○ ○ 44 E1- E2 + -	
SI-LS42DMMHF	24V ac/dc	SI-QM-SMFA Flexible In-Line	SI-LS42DMH	Actuator Contacts 31 ○ ○ 32 21 ○ ○ 22 13 ○ ○ 14	Actuator Contacts 31 ○ ○ 32 21 ○ ○ 22 13 ○ ○ 14	
SI-LS42UMMHF	24-48V dc 24-230V ac		SI-LS42UMH	Solenoid Monitor Contacts 41 ○ ○ 42 E1- E2 + -	Solenoid Monitor Contacts 41 ○ ○ 42 E1- E2 + -	
SI-LS42DMMI	24V ac/dc	SI-QM-SSA Rigid In-Line	SI-LS42DMI	Actuator Contacts 31 ○ ○ 32 21 ○ ○ 22 13 ○ ○ 14	Actuator Contacts 31 ○ ○ 32 21 ○ ○ 22 13 ○ ○ 14	
SI-LS42UMMI	24-48V dc 24-230V ac		SI-LS42UMI	Solenoid Monitor Contacts 41 ○ ○ 42 E1- E2 + -	Solenoid Monitor Contacts 41 ○ ○ 42 E1- E2 + -	
SI-LS42DMMIF	24V ac/dc	SI-QM-SMFA Flexible In-Line	SI-LS42DMI	Actuator Contacts 11 ○ ○ 12 21 ○ ○ 22 31 ○ ○ 32	Actuator Contacts 11 ○ ○ 12 21 ○ ○ 22 31 ○ ○ 32	
SI-LS42UMMIF	24-48V dc 24-230V ac		SI-LS42UMI	Solenoid Monitor Contacts 41 ○ ○ 42 E1- E2 + -	Solenoid Monitor Contacts 41 ○ ○ 42 E1- E2 + -	
SI-LS42DMMJ	24V ac/dc	SI-QM-SSA Rigid In-Line	SI-LS42DMJ	Actuator Contacts 11 ○ ○ 12 21 ○ ○ 22 31 ○ ○ 32	Actuator Contacts 11 ○ ○ 12 21 ○ ○ 22 31 ○ ○ 32	
SI-LS42DMMJF		SI-QM-SMFA Flexible In-Line		Solenoid Monitor Contacts 41 ○ ○ 42 E1- E2 + -	Solenoid Monitor Contacts 41 ○ ○ 42 E1- E2 + -	

† A kit contains an interlock and actuator. Individual interlock bodies and actuators are for replacement purposes only. See Warning on page 12.

*Contacts: □ Open ■ Closed ▒ Transition

Machine Safety Switches – SI-LS42 Series Locking Style Switch

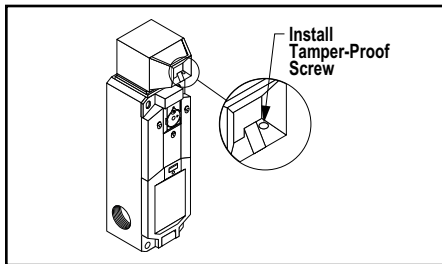

Figure 1. Horizontal actuator head position (as received from the factory): Install tamper-proof screw.

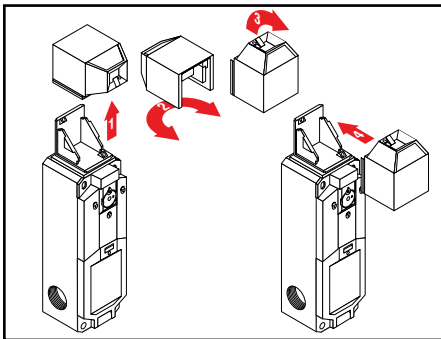

Figure 2. To change actuator head orientation

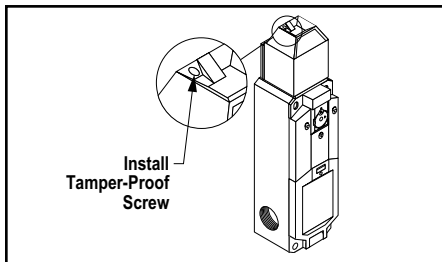

Figure 3. Vertical actuator head position: Install tamper-proof screw.

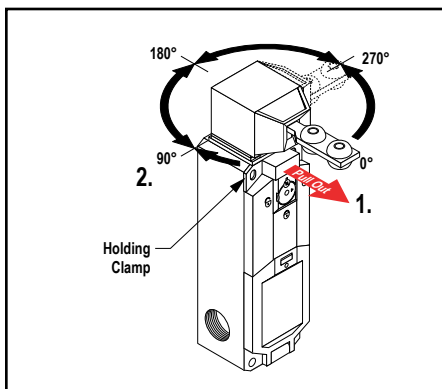

Figure 4. Actuator head rotation

Mechanical Installation

Horizontal or Vertical Actuation

Before installation, orient the switch actuator head for either horizontal (at a right angle to the switch length) or vertical (in-line with the switch length) actuation. The switch is shipped with the actuator head in the horizontal position (Figure 1). If this is the desired orientation, install the M3 x 15 mm tamper-proof (one-way) screw, which is found in a plastic bag, stored in the wiring chamber (see page 6 for information on opening the wiring chamber access door).

If vertical actuation is required, remove the head by pulling straight up and off (Figure 2). Re-orient the actuator head, and slide it back on in the new position until it snaps into place. Install the tamper-proof screw, as shown in Figure 3.

Rotating Actuator Head to Desired Position

The actuator head may be rotated in increments of 90° to create eight possible actuator engagement positions (i.e., four horizontal plus four vertical positions). To rotate the head, pull the holding clamp forward, rotate the head (in either direction) to the desired position, and push the holding clamp back in to lock. The head may be rotated with the actuator either engaged or removed (Figure 4).

Installing the Switch and Actuator

NOTE: All mounting hardware is supplied by the switch user. The fasteners must be of sufficient strength to avoid incidental breakage. Use of permanent fasteners or locking hardware is recommended to prevent loosening or displacement of the actuator and switch body.

The mounting holes in the switch body accept M5 (#10) screws. There are four holes on a mounting pattern of 30 x 124 mm (see dimension drawing of switch, page 10). See page 11 for dimensions of the actuator mounting holes.

Position the switch, with its actuator fully engaged, at the mounting location and mark the mounting holes. Fasten the switch body and the actuator in place. The rigid in-line actuator includes floating sleeves in the mounting holes to allow some forgiveness for switch-to-actuator alignment. If the rigid in-line actuator is used, take care to not over-tighten the actuator fasteners so as to allow this movement. After the mounting hardware is secure, check the actuator/switch engagement for misalignment and binding.

IMPORTANT: A safety switch must be installed in a manner which discourages tampering or defeat. Mount each switch to prevent bypassing of the switching function at the wiring chamber. A switch and its actuator must never be used as a mechanical stop.

Manual Release for Spring Lock Models

Models with spring lock/solenoid unlock may be unlocked manually by rotating the unlock mechanism, using an M3 Allen wrench (not supplied). First loosen the security screw (see dimension drawing of switch, page 10), then turn the unlock mechanism in either direction to the  position.

IMPORTANT: After the switch is installed, check to be certain that the unlock mechanism is in the  position, and that the security screw is tight and covered with tamper-resistant lacquer (user-supplied).

Machine Safety Switches – SI-LS42 Series Locking Style Switch

Electrical Installation

Access to Wiring Chamber

The wiring chamber is accessed via the hinged door. Simply insert a flat-blade screwdriver, as shown in Figure 5, and pry gently down to open. Select the best wiring entrance and thread in the ½" x 14 NPSM conduit adapter (supplied), or the optional M20 x 1.5 cable gland (page 12). The switch knockout will break loose with the final turn of the conduit adapter or cable gland.

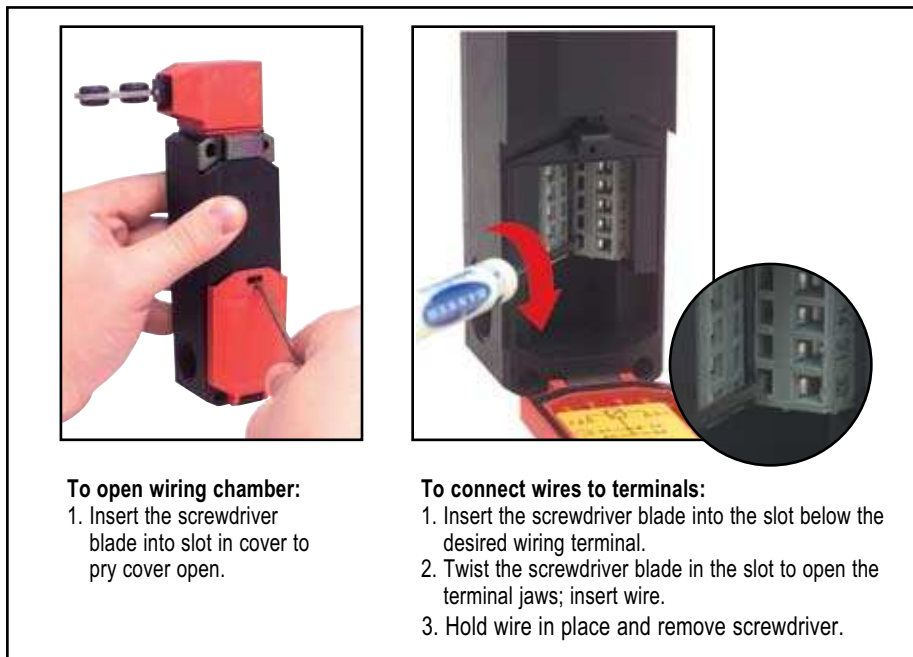

Figure 5. Access to wiring chamber – use a small flat-blade screwdriver

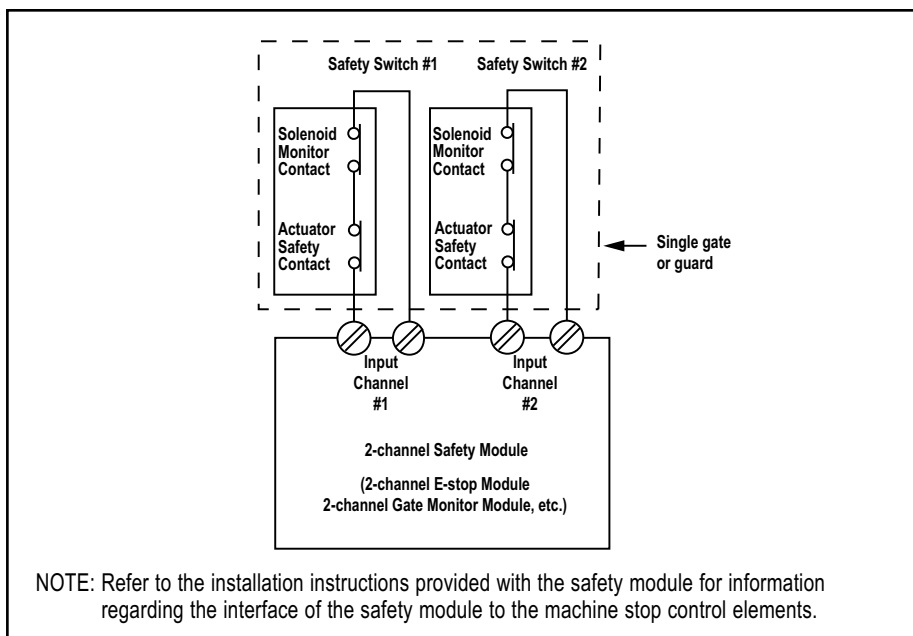

Figure 6. Connect two redundant safety switches per interlock guard to an appropriate 2-channel input safety module.



CAUTION . . .

Electrical Installation

Two safety switches must be used for each interlock guard to achieve control reliability or Safety Category 4 (per ISO 13849-1, EN 954-1) of a machine stop circuit. Use of only one safety switch per interlock guard is not recommended.

In addition, normally-closed safety contacts from each of the two safety switches should be connected to the two separate inputs of a 2-channel safety module or safety interface, as illustrated in Figure 6. This is required to provide monitoring for safety switch contact failure, and to provide the necessary reset routine, as required by IEC 60204-1 and NFPA 79 machine safety standards.



WARNING . . . Series Connection of Safety Interlock Switches

Monitoring multiple guards with a series connection of multiple safety interlock switches is not a Safety Category 4 Application (per ISO 13849-1, EN 954-1). A single failure may be masked or not detected at all. When such a configuration is used, procedures must be performed regularly to verify proper operation of each switch.

Machine Safety Switches – SI-LS42 Series Locking Style Switch



WARNING . . .

It must not be possible for personnel to reach any hazard point through an opened guard (or any opening) before hazardous machine motion has completely stopped. Please reference OSHA CFR 1910.217 and ANSI B11 standards (see page 2) for information on determining safety distances and safe opening sizes for your guarding devices.

Connection to a Machine

Four contacts are offered. Two are safety contacts which must be wired in series, and the other two are considered monitoring contacts which may be used, if desired.

The contact between terminals 11 and 12 or 21 and 22 is a safety contact which is closed (i.e., it conducts) when the actuator is engaged. The contact between terminals 13 and 14 is the associated actuator monitoring contact.

The contact between terminals 31 and 32 is a safety contact which is closed when the solenoid is in its locking state. The contact between terminals 43 and 44 is the associated solenoid monitoring contact.

See the switching diagrams on pages 3 and 4 for contact state information.

Solenoid voltage connects to terminals E1 (+) and E2 (-).

As illustrated in Figure 6, the normally-closed safety contacts (i.e., safety contacts that are closed when the actuator is engaged and the solenoid is in its locking state) from **each of two safety switches per interlock guard** must connect to a 2-channel safety module or safety interface in order to achieve a control reliable interface to the master stop control elements of a machine.

Examples of appropriate safety modules include 2-channel emergency stop (E-stop) safety modules and gate monitor safety modules.

Two functions of the safety module or safety interface are:

1. To provide a means of monitoring the contacts of both safety switches for contact failure, and to prevent the machine from restarting if either switch fails; and
2. To provide a reset routine after closing the guard and returning the safety contacts to their closed position. This prevents the controlled machinery from restarting by simply reinserting the safety switch actuators. This necessary reset function is required by ANSI B11 and NFPA 79 machine safety standards.

Use only positively-driven, normally-closed safety contacts from each switch for connection to the safety module. *The normally-open contacts may be used for control functions that are **not safety-related**.* A typical use is to communicate with a process controller. Refer to the installation instructions provided with the safety modules for more information regarding the interface of the safety module to the machine stop control elements.

Machine Safety Switches – SI-LS42 Series Locking Style Switch

Periodic Checks

Periodic checks should be performed only by Designated Persons or Qualified Persons, as specified below. Safety switches should be checked at each shift change or machine setup by a Designated Person (see below) for:

1. Breakage of the switch body or actuator,
2. Good alignment and full engagement of the actuator with the receptor,
3. Confirmation that the safety switch is not being used as an end stop,
4. Loosening of the switch or actuator mounting hardware, and
5. Verification that it is not possible to reach any hazard point through an opened guard (or any opening) before hazardous machine motion has completely stopped.

In addition, a Qualified Person should check for the following on a periodic schedule, determined by the user, based upon the severity of the operating environment and the frequency of switch actuations:

1. Check the wiring chamber for signs of contamination.
2. Check the contacts for signs of deterioration or damage.
3. Inspect the electrical wiring for continuity and damage.
4. Verify that wiring conforms to the instructions on pages 8 to 10 of this data sheet.

A Designated Person is identified in writing by the employer as being appropriately trained to perform a specified checkout procedure. A Qualified Person possesses a recognized degree or certificate or has extensive knowledge, training, and experience to be able to solve problems relating to the safety switch installation (ANSI B30.2).

Repairs



NOTE: Do not attempt any repairs to the switch. It contains no field-replaceable components. Return the switch to the factory for warranty repair or replacement.

If it ever becomes necessary to return a switch to the factory, please do the following:

1. Contact the Banner applications engineering department at the number or address listed on the front cover. They will attempt to troubleshoot the system from your description of the problem. If they conclude that a component is defective, they will issue an RMA (Return Merchandise Authorization) number for your paperwork, and give you the proper shipping address.
2. Pack the switch carefully. Damage which occurs in shipping is not covered by warranty.

Machine Safety Switches – SI-LS42 Series Locking Style Switch

Specifications

Contact Rating	4A @ 250V ac max. 2.5 kV max. transient tolerance NEMA A300 P300														
European Rating	Utilization categories: AC15 and DC13 (IEC 60947-5-1) Switches with 1 and 2 contact pairs: $U_i = 250V$ ac $I_{th} = 2.5A$	40-60 Hz													
		<table border="1"> <thead> <tr> <th>U_e V</th> <th>$I_e/AC-15$ A</th> <th>$I_e/DC-13$ A</th> </tr> </thead> <tbody> <tr> <td>24</td> <td>4</td> <td>3</td> </tr> <tr> <td>110</td> <td>4</td> <td>0.77</td> </tr> <tr> <td>230</td> <td>4</td> <td>0.3</td> </tr> </tbody> </table>	U_e V	$I_e/AC-15$ A	$I_e/DC-13$ A	24	4	3	110	4	0.77	230	4	0.3	
U_e V	$I_e/AC-15$ A	$I_e/DC-13$ A													
24	4	3													
110	4	0.77													
230	4	0.3													
Contact Material	Silver-nickel alloy														
Solenoid Power Consumption	1.1 VA / Inrush 56 VA (0.2 sec)														
Maximum Actuator Speed	1.5 m/second (5"/second)														
Minimum Actuator Engagement Radius	In-line actuators: 400 mm (16") Flexible actuators: 150 mm (6")														
Actuator Extraction Force	2000 Newtons (440 lbf) when locked														
Short Circuit Protection	6 amp Slow Blow, 10 amp Fast Blow. Recommended external fusing or overload protection.														
Mechanical Life	1 million operations														
Wire Connections	10 cage clamp elements 1.5 mm stranded max. / 16 AWG														
Cable Entry	M20 x 1.5 threaded entrance. Adapter supplied to convert M20 x 1.5 to 1/2" - 14 NPT threaded entrance.														
Construction	Glass fiber-reinforced polyimide thermoplastic housing; UL 94-V0 rating														
Environmental Rating	IEC IP67														
Operating Conditions	Temperature: -30° to +70° C (-22° to +158° F)														
Weight	0.3 kg														
Certifications	  														

Machine Safety Switches – SI-LS42 Series Locking Style Switch

Dimensions

Model SI-LS42.. Interlock Body

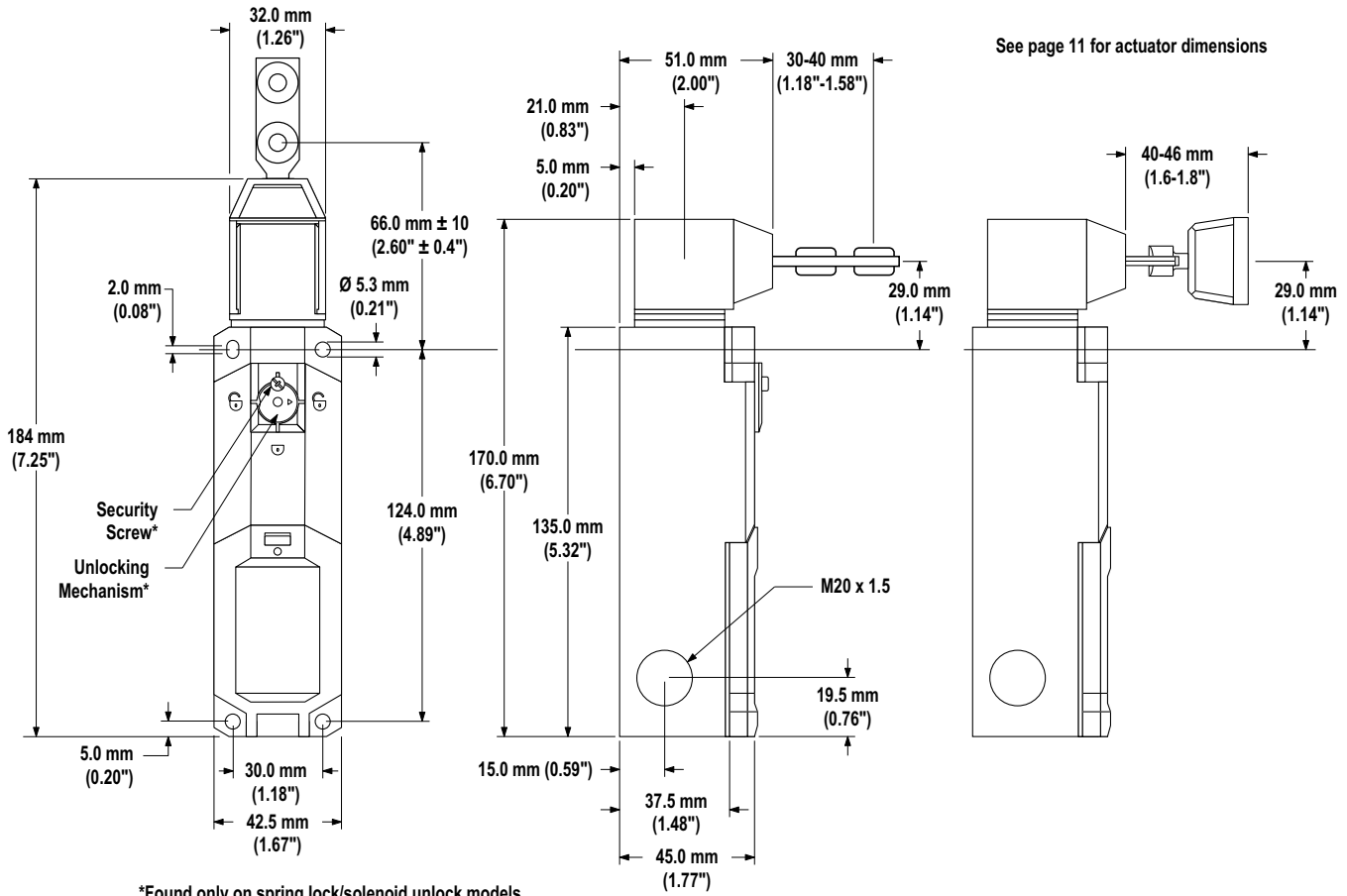

Machine Safety Switches – SI-LS42 Series Locking Style Switch

Actuator Dimensions

SI-QM-SSA Rigid In-Line Actuator

400 mm (16") minimum actuator engagement radius

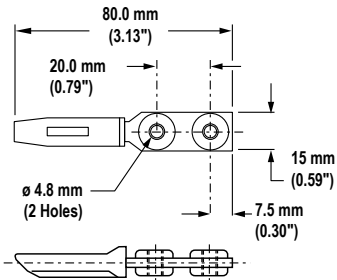

SI-QM-SMFA Flexible In-line Actuator

150 mm (6") minimum actuator engagement radius

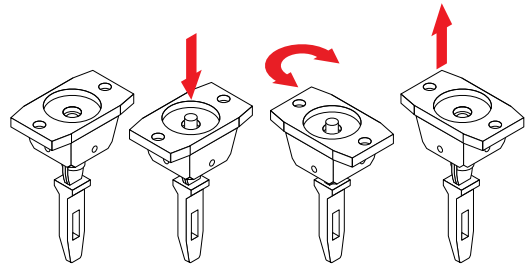
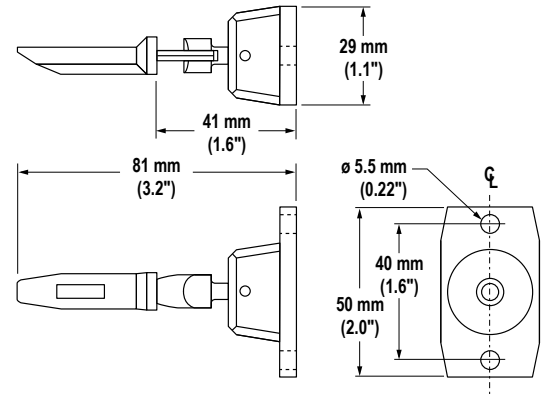

The flexible actuator mounting flange may be rotated 90° with respect to the actuator position. To rotate, push the flange in the direction of actuation, turn the flange either direction, and release to lock the flange in the new position; see the diagram above.

Machine Safety Switches – SI-LS42 Series Locking Style Switch

Accessories

Cable Glands

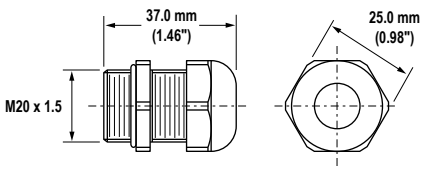
Size	Model	Used with Switch Models	For Cable Diameters	Dimensions
M20 x 1.5 Plastic	SI-QS-CGM20	All	5.0 to 12.0 mm (0.20" to 0.47")	

Replacement Parts

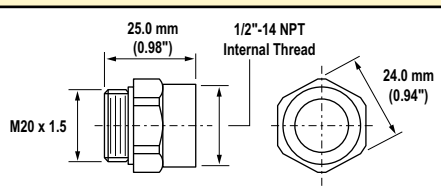
Description	Model	Used with Switch Models	Dimensions
1/2"-14 NPT Plastic Conduit Adaptor	SI-QS-M20	All	
Replacement Terminal Cover	SI-LS42-COVER	All	N/A

Accessory Actuators

Description	Model	Used with Switch Models	
Rigid In-line metal actuator used for doors or covers. Slide-bolt design for use in heavy-duty applications where alignment is difficult to maintain.	SI-QM-SB	All	



WARNING . . .

Spare actuators must NEVER be used to bypass or otherwise defeat the protective function of a safety switch. To do so may create an unsafe situation which could lead to serious injury or death.



the machine safety specialist

WARRANTY: Banner Engineering Corp. warrants its products to be free from defects for one year. Banner Engineering Corp. will repair or replace, free of charge, any product of its manufacture found to be defective at the time it is returned to the factory during the warranty period. This warranty does not cover damage or liability for the improper application of Banner products. This warranty is in lieu of any other warranty either expressed or implied.