

DUO-TOUCH[®] – Two-Hand Control Modules

Models *AT-FM-2A*, *AT-AM-2A*, and *AT-BM-2A*, for Use with Two Actuating Devices



Features

- Two redundant, forced-guided (mechanically linked) output contacts rated at 4 A
- One auxiliary N.C. relay output rated at 0.5 A
- Feedback input for monitoring external machine control elements
- Four indicator LEDs for Power, Input 1, Input 2, and Fault
- 24V ac/dc, 115V ac, or 230V ac operation, depending on model
- DIN-rail-mountable 45-mm-wide housing
- 500 ms (max.) simultaneity requirement for touch-/push-button operation

Description

A DUO-TOUCH Two-Hand Control Safety Module may be used with:

- Two Banner OTB Optical Touch Buttons, each with one normally open relay output contact, or
- Two Banner OTB Optical Touch Buttons, one with current-sourcing PNP output, and one with current-sinking NPN output, or
- Two mechanical push buttons, each with one normally open contact

If the machine operator removes one or both hands from the actuating device(s), the DUO-TOUCH Module relays de-energize, causing the output contacts to open. The relays will not re-energize until both actuating devices are deactivated and then simultaneously reactivated (SSI input channels closed).

The DUO-TOUCH Two-Hand Control system has been designed to meet:

- Type IIIA/B requirements of ISO 13851 (EN 574) Safety of Machinery – Two-Hand Control Devices, and
- Category 1 and 3 requirements of ISO 13849-1 (EN 954-1) Safety of Machinery – Safety-Related Parts of Control Systems – Part 1: General Principles of Design

The Safety Module's output signal consists of two sets of redundant, forced-guided (mechanically linked) contacts (see figures on page 8). Circuitry within the Safety Module is Category 4 (per EN954-1) without consideration of the inputs. This circuitry monitors the internal contacts and prevents an output signal from occurring if a fault is detected. A feedback loop is offered for monitoring the status of the machine control elements.



**WARNING ...
Point-of-Operation
Guarding**

When properly installed, the DUO-TOUCH Two-Hand Control Safety Module provides protection only for the hands of the machine operator. It may be necessary to install additional safeguarding, such as safety light screens and/or hard guards, to protect personnel from hazardous machinery.

Failure to properly guard hazardous machinery can result in a dangerous condition which could lead to serious injury or death.

DUO-TOUCH® – Models AT-..M-2A Two-Hand Control Modules



Important ... read this page before proceeding!

In the United States, the functions that the Banner DUO-TOUCH Two-Hand Control Module is intended to perform are regulated by the Occupational Safety and Health Administration (OSHA). Whether or not any particular DUO-TOUCH Two-Hand Control Module installation meets all applicable OSHA requirements depends upon factors that are beyond the control of Banner Engineering Corp. These factors include the specific ways the safety module is applied, installed, wired, operated, and maintained.

Banner Engineering Corp. has attempted to provide complete application, installation, operation, and maintenance instructions. In addition, we suggest that any questions regarding the use or installation of this two-hand control safety system be directed to the factory applications department at the telephone numbers or address shown on the back cover of this manual.

The user of this Two-Hand Control Safety Module must ensure that all machine operators, maintenance personnel, electricians, and supervisors are thoroughly familiar with and understand all instructions regarding the installation, maintenance, and use of this system, and with the machinery upon which it is installed.

The user and any personnel involved with the installation and use of this Safety Module must be thoroughly familiar with all applicable OSHA regulations and ANSI standards. The regulations and standards, listed below, directly address the use of two-hand control systems. Banner Engineering Corp. makes no claim regarding a specific recommendation of any organization, the accuracy or effectiveness of any information provided, or the appropriateness of the provided information for a specific application.

The user has the responsibility to ensure that all local, state, and national laws, rules, codes, and regulations relating to the use of this Two-Hand Control Module are satisfied. Extreme care is urged that all legal requirements are met and that all installation and maintenance instructions contained in this manual are followed.

U. S. Standards Applicable to Use of Two-Hand Control Systems

ANSI B11 Standards for Machine Tools “Safety Requirements for the Construction, Care and Use”
Available from: Safety Director
AMT – The Association for Manufacturing Technology
7901 Westpark Drive
McLean, VA 22102
Tel.: 703-893-2900 Fax: 703-893-1151

NFPA79 “Electrical Standard for Industrial Machinery”
Available from: National Fire Protection Association
1 Batterymarch Park, P.O. Box 9101
Quincy, MA 02269-9101
Tel.: 800-344-3555

ANSI/RIA R15.06 “Safety Requirements for Industrial Robots and Robot Systems”
Available from: Robotic Industries Association
900 Victors Way, P.O. Box 3724
Ann Arbor, MI 48106
Tel.: 734-994-6088

International Standards Applicable to Use of Two-Hand Control Systems

ISO/TR12100-1 & -2 “Safety of Machinery – Basic Concepts, General Principles for Design, Part 1: Basic Terminology, Methodology”, and
(EN292-1 & -2) “Part 2: Technical Principles and Specifications”

IEC/EN60204-1 “Electrical Equipment of Machines: Part 1: General Requirements”
Also, request a type “C” standard for your specific machinery.

ISO13849-1 (EN954-1) “Safety of Machinery – Safety Related Parts of Control Systems”

ISO13855 (EN999) “Safety of Machinery – The Positioning of Protective Equipment”

ISO13851 (EN574) “Safety of Machinery – Two-Hand Control Devices”

Available from: Global Engineering Documents
15 Inverness Way East
Englewood, CO 80112-5704
Tel.: 800-854-7179

DUO-TOUCH® – Models AT-..M-2A Two-Hand Control Modules

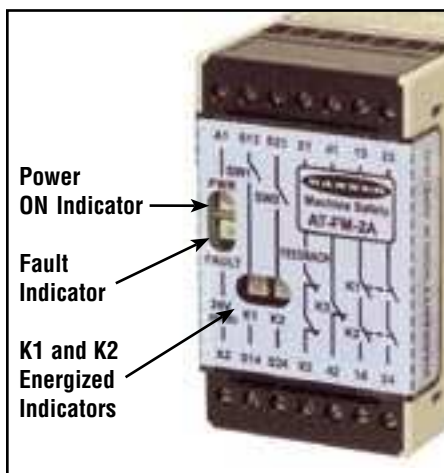

Figure 1. AT-..M-2A status indicators



CAUTION ... Not an Anti-Repeat Control Device

Anti-repeat control is not a function of the AT-..M-2A Two-Hand Control Safety Module. The user of this device must provide a suitable means of anti-repeat control for any single-stroke or single-cycle machines.



WARNING ... Avoid Hazardous Installations

The user has the responsibility to satisfy all local, state, and national laws, rules codes, and regulations relating to the use of safety equipment in any application. It is extremely important to be sure that all appropriate agency requirements have been met and that all installation and maintenance instructions contained in the appropriate manuals are followed.

Appropriate Applications

The DUO-TOUCH Two-Hand Control Safety Module may be used as an initiation device for most powered machinery when machine cycling is controlled by a machine operator.

Using a two-hand control system makes the operator a “hostage” while the hazard is present, thus limiting or preventing exposure to the hazard. The two-hand control actuators must be located in a way that hazardous motion is completed or stopped before the operator can release one or both of the buttons and reach the hazard (see **Separation Distance** on page 6).

Simultaneous use of both hands is required, meaning that both buttons must be actuated within a very short time span. The time span is specified by ANSI/RIA R15.06, ANSI/NFPA79, and ISO 13851 (EN 574) as not more than 500 ms, even under single-fault conditions. This requirement reduces the possibility of intentional defeat and unintended initiation of the machine cycle.

When used in single-cycle or single-stroke mode, the machine control must provide an anti-repeat feature so that the operator must release the two-hand control actuators after each machine cycle, before a new cycle can be initiated.

The actuating devices must be protected from accidental or unintended operation. This can be accomplished by their mounting position and/or through the use of protective shields such as rings, guards or shields; see Figure 3.

NOTE: Two-hand control and two-hand trip safeguarding protect *only the operator's hands*. Additional safeguarding may be required. The user must refer to the relevant standards for additional requirements for the application of two-hand control and two-hand trip devices when used for safeguarding.

Part-Revolution Clutched Machinery

A two-hand control safety module can be used for the following functions: “inch” (jog), “single-stroke,” or “continuous” (run). Two-hand control safety modules are recognized as a means of protecting the machine operator when the hand controls are safely located and protected from false operation (see **Mechanical Installation** on pages 4-5 and **Separation Distance** on page 6) and when properly interfaced to the machine (see **Electrical Installation** on page 7) to control the required stopping action.

Full-Revolution Clutched Machinery

A two-hand control safety module used to initiate the cycle of a full-revolution clutched machine is known as a “two-hand trip device.” Two-hand trip devices are recognized as a means of protecting the machine operator when the hand controls are safely located and protected from false operation (see **Mechanical Installation** on pages 4-5 and **Separation Distance** on page 6) and when properly interfaced to the machine (see **Electrical Installation** on pages 6-7) to prevent accidental cycle initiation.

DUO-TOUCH® – Models AT-..M-2A Two-Hand Control Modules

Theory of Operation

The input circuit of the DUO-TOUCH Safety Module requires simultaneous actuation (within 0.5 seconds of each other) of both two-hand control actuators to generate an output signal.

The timing diagram in Figure 2 illustrates that an output signal from the DUO-TOUCH Safety Module occurs only if switches #1 and #2 (SW1 and SW2) are actuated within 0.3 seconds of each other (300 ms typical, not more than 500 ms under single-fault conditions). The output signal drops within 25 milliseconds following the release of either switch. The device output does not reenergize until both hand controls are disengaged, and then simultaneously re-actuated. This logic reduces the possibility of defeating the two-hand control system by tying down one or both actuators.

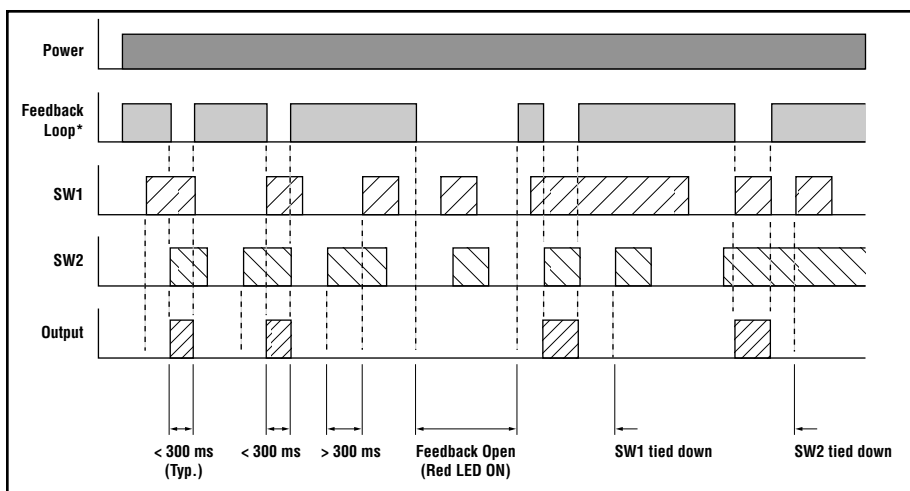

Figure 2. DUO-TOUCH Safety Module AT-..M-2A timing diagram

Mechanical Installation

The DUO-TOUCH Safety Module must be installed inside a NEMA 3 (IEC IP54) rated, or better, enclosure. It is not designed for exposed wiring. Safety Module dimensions are shown in Figure 6. The device mounts directly onto standard 35 mm DIN rail.

Heat Dissipation Considerations

For reliable operation, the user must ensure that the operating specifications are not exceeded. The enclosure must provide adequate heat dissipation, so that the air closely surrounding the Module does not exceed the maximum operating temperature stated in the Specifications (page 11). Methods to reduce heat build-up include venting, forced airflow (e.g., exhaust fans), adequate enclosure exterior surface area, and spacing between modules and other sources of heat.

DUO-TOUCH® – Models AT-.M-2A Two-Hand Control Modules



CAUTION ... Install Hand Controls to Prevent Accidental Actuation

Total protection for the two-hand control system from “defeat” is not possible. However, regulations require the user to arrange and protect hand controls to minimize possibility of defeat or accidental actuation.



CAUTION ... Hand Controls

The environment in which hand controls are installed must not adversely affect the means of actuation. Severe contamination or other environmental influences may cause slow response or false ON conditions of mechanical or ergonomic buttons. **This may result in exposure to a hazard.**

Installation of Hand Controls

Each actuating device requires a normally open (e.g., SPST) hard contact capable of reliably conducting 20mA at 12V dc. For solid-state operation, model OTBVN6.. and OTBVP6.. touch buttons must be used to ensure proper functionality.

Standards require that the actuating devices be mounted to protect them from accidental or unintentional operation. Use shields, covers, rings, collars, dividers, or similar protection to prevent accidental switch actuation and to discourage use of forearms or elbows. European standard ISO13851 includes a detailed discussion of approaches to protection of hand controls.

The hand controls must be arranged far enough apart so that the operator cannot operate both hand controls by the use of one arm (typically, not less than 550 mm/21.7" in a straight line, per ISO13851).

Figure 3 shows two examples for mounting Banner’s OTB Touch Buttons. When mounted on top of the control bar, the protective field covers should be in place, as shown. For added protection, mount the devices sideways under and behind a protective hood, rather than on top of the bar, leaving the field covers off. This side mount reduces the possibility of the operator easily positioning and leaving an object in the path of the beam, intentionally bypassing the safeguard.

The hand controls must be arranged far enough apart so that the operator cannot operate both hand controls using only one hand. Typically, this distance is not less than 550 mm (21.7"), but using guards or an alternate mounting arrangement can allow a shorter distance, per ISO13851 (EN574). This standard also recommends that the hand control be arranged on a horizontal (or nearly horizontal) surface that is not less than 1,100 mm (43.3") above the floor.

Employ ergonomic principles to avoid unnecessary fatigue in the use of the hand controls. See ISO13851 (EN574) Two-Hand Control, ANSI B11.TR1–Ergonomic Guidelines, and EN894–Safety of Machinery–Ergonomic Requirements–Control Actuators for further information.

Requirements for Multiple-Operator Control

Standards have specified several conditions for situations where multiple operators work together to control one machine:

- Each operator must actuate his/her own pair of actuating devices, with all pairs of actuators active at one time, in order to initiate a machine cycle; the machine may not be allowed to operate until this condition is true.
- The actuators all must be released between cycles.
- The actuation and de-actuation of all workstations requiring two-hand control must be supervisable and must provide indication.
- The clutch/brake control system must be designed so that the clutch cannot be actuated if all the operating workstations are bypassed.

It is the responsibility of the user to determine if this two-hand control system can be interfaced to the machine in a manner to satisfy all existing requirements for multiple-operator control.

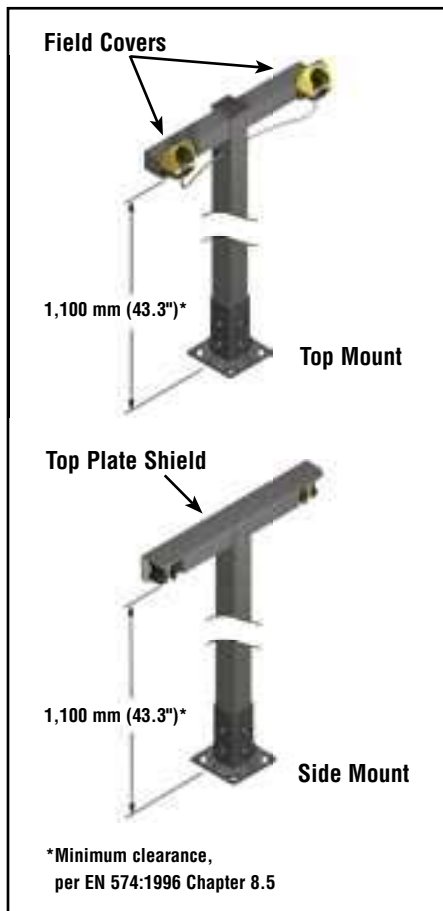

Figure 3. Protect activation devices in order to prevent defeat or inadvertent actuation

DUO-TOUCH® – Models AT-..M-2A Two-Hand Control Modules

Separation Distance

Both hand controls must be located far enough away from the nearest hazard point that the operator cannot reach the hazard with a hand or other body part before the hazardous motion ceases. This is the “separation distance,” and may be calculated as follows:

For Part-Revolution Clutch Machinery

Where the machine and its controls allow the machine to stop motion during the hazardous portion of the machine cycle, use the following formula:

$$D_s = K \times (T_s + T_r + T_h)$$

For Full-Revolution Clutch Machinery

Where the machine and its controls are designed to complete a full machine cycle, once activated, use the following formula:

$$D_s = K \times (T_m + T_r + T_h)$$

For both formulas:

D_s = the separation distance in millimeters or inches,

K = 1600 mm (63") per second (the hand speed constant currently accepted by OSHA; see NOTE 1)

T_s = the stop time (in seconds) of the machine, measured from the application of the “stop” signal to the final ceasing of all motion, including stop times of all relevant control elements, and measured at maximum machine velocity (see NOTE 2)

T_r = 0.025 seconds (the response time of the Safety Module as measured from the time either hand disengages a hand control)

T_h = the response time of the slowest hand control (from the time when a hand disengages that control until the switch opens; see NOTE 3)

T_m = the maximum time (in seconds) the machine takes to cease all motion after it has been tripped. For full-revolution clutch presses with only one engaging point, T_m is equal to the time necessary for 1.5 revolutions of the crankshaft. For full-revolution clutch presses with more than one engaging point, T_m is calculated as follows:

$$T_m = (1/2 + 1/N) \times T_{cy}$$

where:

N = number of clutch engaging points per revolution

T_{cy} = time (in seconds) necessary to complete one revolution of the crankshaft

Electrical Installation

Because the DUO-TOUCH Safety Module interfaces to many types of machine controls, it is not possible to give exact wiring instructions here. The following guidelines are general in nature.

Connection of Input Switches

The actuation devices are connected to the DUO-TOUCH module as shown in Figures 5 a, b, and c. SW1 and SW2 must both be isolated normally-open switches capable of reliably switching up to 20 mA, at 12V dc. If hand controls have metal housings, the housings must be connected to protective earth ground.

If OTB Touch Buttons with PNP/NPN outputs are used, the System must be connected as shown in Figure 5b. Electronic actuation devices other than OTB Touch Buttons must share the same voltage supply with the Safety Module (see Electronic Hand Control WARNING on page 7).



WARNING ... Location of Touch Button Controls

Hand controls must be mounted at a safe distance from moving machine parts, as determined by the appropriate standard. It must not be possible for the operator or other non-qualified persons to relocate them. Failure to establish and maintain the required safety distance could result in serious injury or death.

Example Separation Distance (D_s) Calculation

The following example illustrates the use of the formula to calculate separation distance for a part-revolution clutch machine. This example uses 0.50 seconds as a typical value for T_s and 0.10 seconds for T_h :

K = 1600 mm (63") per second,

T_s = 0.50 seconds (measured by a stop-time measuring device)

T_r = 0.025 seconds

T_h = 0.10 seconds

$D_s = K \times (T_s + T_r + T_h)$
= 1600 mm (or 63") (0.50 + 0.025 + 0.10)
= 1000 mm (39.4")

In this example, both hand controls must be located no closer than 1000 mm (39.4") from the nearest hazard point.

NOTES:

- 1) The OSHA-recommended hand speed constant K has been determined by various studies, and although these studies indicate speeds of 1600-2500 mm/sec (63"/sec to over 100"/sec), they are not conclusive determinations. The employer should consider all factors, including the physical ability of the operator, when determining the value of K to be used.
- 2) T_s is usually measured by a stop-time measuring device. If the specified machine stop time is used, add at least 20% as a safety factor to account for brake system deterioration. If the stop-time of the two redundant machine control elements is unequal, the slower of the two times must be used for calculating the separation distance.
- 3) T_h is usually insignificant for purely mechanical switches. However, T_h should be considered for separation distance calculation when using electronic or electromechanical (i.e., powered) hand controls. In this example, OTB response time = 0.10 seconds.

DUO-TOUCH® – Models AT-..M-2A Two-Hand Control Modules



CAUTION ... Disconnect Power Before Wiring

Always disconnect all power from the DUO-TOUCH Safety Module and the machine being controlled before making any wire connections.

Electrical installation of hand controls, the DUO-TOUCH SG Safety Module, and the interconnection to the machine control must be made by qualified personnel and must comply with NEC (National Electrical Code), ANSI/NFPA79 or IEC60204-1, and all applicable local standards.

Connection of Power to the DUO-TOUCH Safety Module

The Safety Module requires a 24V dc, 115V ac or 230V ac supply voltage (see Specifications on page 11). Use extreme caution whenever installing ac power. Use a minimum of 16 to 18 AWG wire for power and output connections. A hand-operated supply disconnect (e.g. a circuit breaker) must be provided (per NFPA79 and IEC/EN60204).

Connection to the Machine to be Controlled

Figure 5d shows a generic connection of the Safety Module's two redundant output contacts to machine primary control elements MPCE1 and MPCE2. An MPCE is defined as an electrically-powered element, external to the safety module, which directly controls the machine's normal operating motion so that it is the last (in time) to operate when motion is either initiated or arrested. Some older machines offer only one MPCE; for such machines, it may be necessary to add a second MPCE to establish the appropriate level of safety integrity.



WARNING ... Use of Electronic Hand Controls

Electronic (powered) hand controls include optical touch buttons, capacitive touch buttons and similar devices. **When electronic hand controls are used as input switches for a DUO-TOUCH Safety Module, the hand controls and the Safety Module must be powered from the same voltage source. Failure to do so creates a potentially dangerous condition, which could result in serious injury or death.**

If power is applied to the Safety Module before power is applied to the electronic hand controls, an output from the DUO-TOUCH Safety Module could result and may trigger machine motion. Also, electronic hand controls cannot guarantee the state of their outputs at the time power is applied to them.

The connection of the safety outputs must be in such a manner that the stop command issued by the AT-..M-2A can not be overridden by a device or circuit that is not at the same level of safety integrity. This means that the safety outputs are interfaced on the output of the machine logic (e.g., PLC or PC). Then, normally, a feedback signal identifies to the machine logic the status of the Safety Module and, if possible, the status of the MPCEs. If interposing relays are used, they must be of mechanically linked (forced-guided) design and monitored by the MPCE Monitoring Circuit (X1/X2).

As shown in Figure 5d, a normally-closed, mechanically linked monitor contact from each of the two MPCEs must be connected in series across terminals X1 and X2. This allows the Safety Module to monitor the state of the MPCEs, and to prevent a successive machine cycle, if an MPCE fault is detected. There is a timing requirement associated with the operation of X1 and X2 inputs. The monitoring contacts of external relays must close within 200 ms following deactivation of the AT-..M-2A outputs. If this requirement is not met or an internal fault is detected, the unit enters a lockout mode (indicated by Fault LED ON Red). **A power cycle is required to exit the lockout.** See Figure 4 and Caution on page 10.

When MPCE monitor contacts are not available, a jumper wire must be installed across terminals X1 and X2.

When a jumper wire is used (dotted line between X1 and X2 in Figure 5d), it is the user's responsibility to provide an appropriate level of safety for the means of machine interfacing to ensure that any single MPCE component failure will not result in the loss of safety.

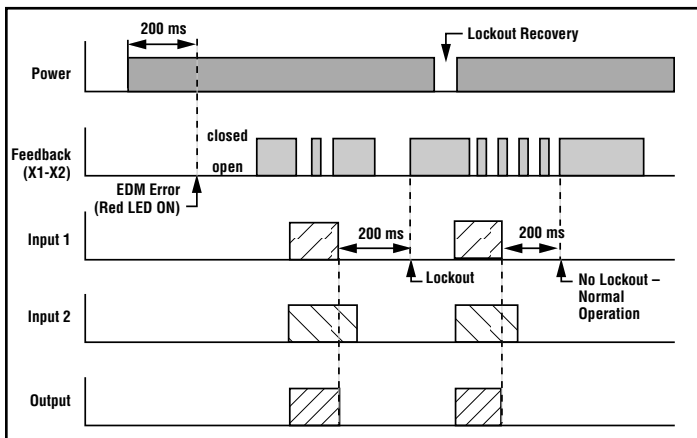

Figure 4. X1 and X2 Input timing requirements

When switching inductive ac loads, it is good practice to protect the Safety Module outputs by installing appropriately-sized arc suppressors. However, if arc suppressors are used, they must be installed across the load being switched (e. g., across the coils of external safety relays), and never across the Safety Module's output contacts (see WARNING on page 8).

DUO-TOUCH® – Models AT-..M-2A Two-Hand Control Modules

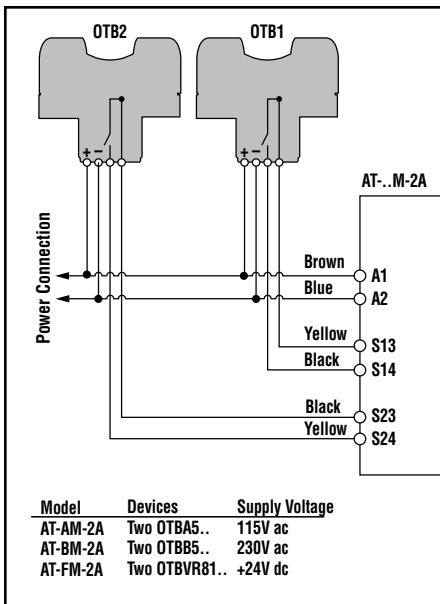

Figure 5a. Type IIIA hookup to two OTB touch buttons with contact outputs

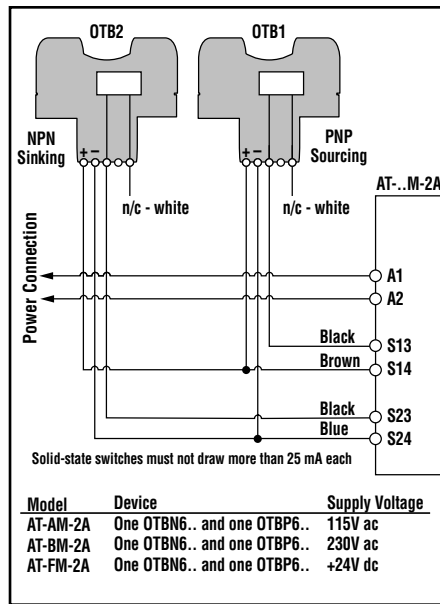

Figure 5b. Type IIIA hookup to two OTB touch buttons with PNP/NPN outputs

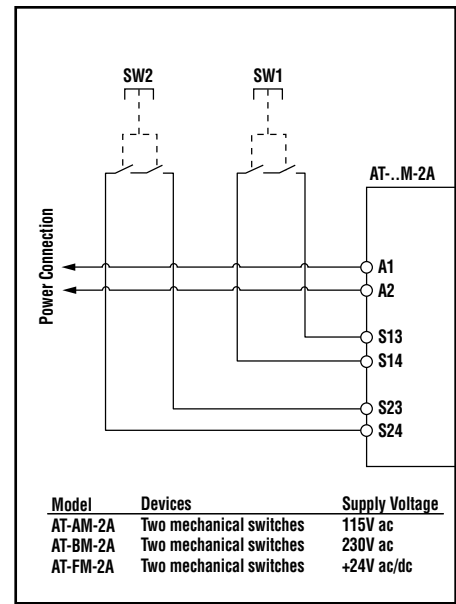

Figure 5c. Type IIIB hookup to two mechanical push buttons with contact outputs

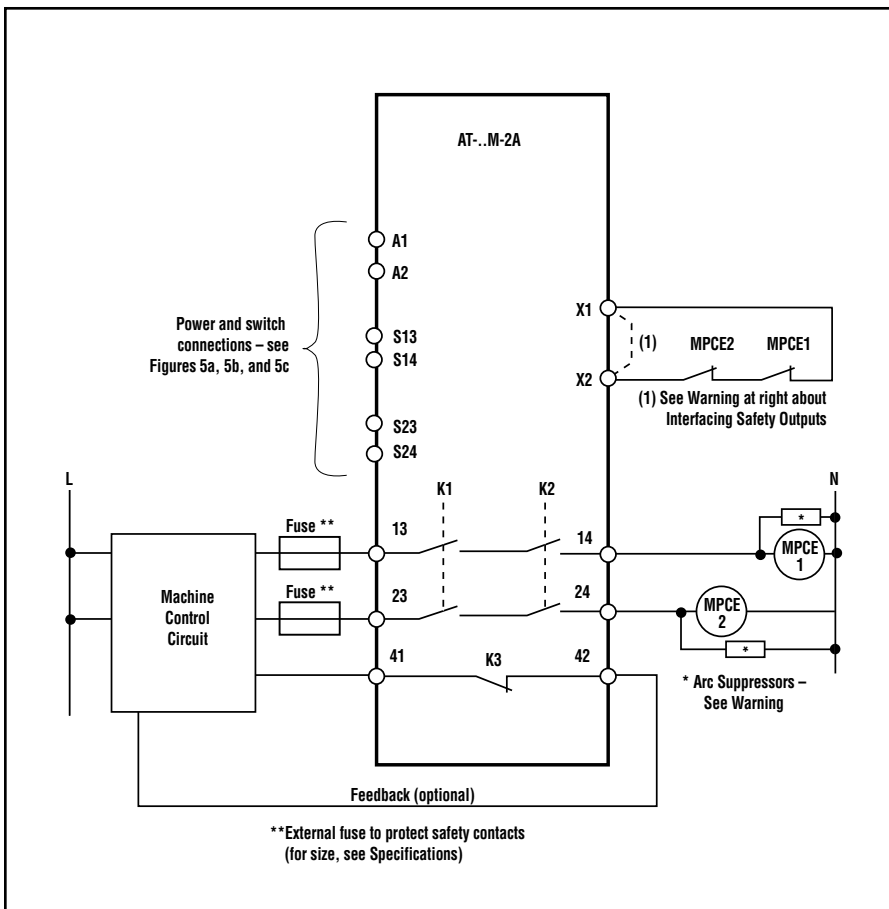

Figure 5d. Machine control circuit connections



WARNING ... Use of Arc Suppressors

If arc suppressors are used, they **MUST** be installed as shown across the coils of the Machine Primary Control Elements (MPCEs). **NEVER install suppressors directly across the output contacts of the DUO-TOUCH Safety Module.** It is possible for suppressors to fail as a short circuit. **If installed directly across the output contacts of the DUO-TOUCH Safety Module, a short-circuited suppressor will create an unsafe condition which could result in serious injury or death.**



WARNING ... Interfacing Safety Outputs

Never wire or interface an intermediate device (e.g., PLC, PES, PC) that can fail in such a manner that there is the loss of the safety stop command to the MPCEs. To do so could result in serious bodily injury. See page 7, **Connection to the Machine to be Controlled.**

DUO-TOUCH® – Models AT-. .M-2A Two-Hand Control Modules



CAUTION ... Disconnect Power Before Checkout

Before performing the initial checkout procedure, make certain all power is disconnected from the machine to be controlled. Temporarily disconnect the wires connected to the outputs of the DUO-TOUCH SG Safety Module at terminals 13/14, 23/24, and 41/42.



WARNING ... Do Not Use System Until Checkouts Are Verified

If all of the described checks cannot be verified, the two-hand-control system must not be used until the problem has been corrected. Injury or death to personnel may result from attempts to use the machine under such conditions.

Initial Checkout Procedure

To perform the initial checkout, it is necessary to view the Status indicators: Power, Fault, K1 and K2. Proceed with caution around open wiring.

- 1) Verify that two actuating devices are properly connected to the DUO-TOUCH Safety Module.
- 2) Apply power to the Safety Module and to the actuating devices, if applicable.
- 3) Verify that only the Power indicator is ON. If any other Safety Module indicators are ON, disconnect the power to the Safety Module and check all wiring. **Do not continue this checkout procedure until the cause of the problem is corrected.**
- 4) Activate one hand control and hold it engaged for 2 seconds, then release. Repeat this step for other hand control. **If the module locks out, do not continue this checkout procedure until the cause of the problem is corrected.**
- 5) Activate both hand controls simultaneously (within 0.3 seconds), and hold them engaged. K1 and K2 indicators should come ON. Release both hand controls simultaneously. K1 and K2 indicators should go OFF.
- 6) Again, activate the two hand controls simultaneously, and hold them engaged. K1 and K2 indicators should come ON. Release one hand control while holding the other engaged. One of the indicators should turn OFF. Re-activate the hand control that was just released. The indicator that was OFF should remain OFF. Release both hand controls. K1 and K2 indicators should then be OFF. Repeat for other hand control.
- 7) Activate only one hand control and hold it engaged. K1 (or K2) indicator should come ON. After more than 1/2 second, activate the second hand control. K1 (or K2) indicator should remain ON, while K2 (or K1) indicator remains OFF. Repeat for other hand control.
- 8) Remove power from the Safety Module and disconnect the monitor contact feedback loop at terminal X1 or X2. Re-apply power to the Safety Module. Activate both hand controls simultaneously. K2 indicator LED should remain OFF, and the Module should lock out.

If the DUO-TOUCH Safety Module passes all of these tests, reconnect the output wires at terminals 13/14, 23/24, and 41/42. Also reconnect the monitor contact feedback loop at terminals X1 and X2. **Do not attempt to use the DUO-TOUCH Two-Hand Control Safety Module until all of the previous tests are passed.**

Periodic Checkout and Maintenance

Daily Checkout: To be performed at every power-up, shift change, and machine setup change. Daily checkout and checkouts after tooling and machine setup changes must be performed by a Designated Person, appointed and identified in writing by the employer.

- 1) Verify that all point-of-operation guards are in place and operating properly.
- 2) Verify that the two actuating devices must be simultaneously engaged to actuate the machine.
- 3) **For single-cycle machines:** Verify that maintained engagement of the two actuating devices results in only one machine cycle.
- 4) **For part-revolution clutch machinery:** Verify that release of either actuating device results in the immediate arrest of the machine motion.
- 5) Verify that the distance from each actuating device to the closest hazard point is not less than the calculated separation (safety) distance (see page 6).

DUO-TOUCH® – Models AT-..M-2A Two-Hand Control Modules

Semi-Annual Checkout: To be performed at six-month intervals. This semi-annual checkout must be performed by a Qualified Person (see definition below). A copy of the test results should be kept on or near the machine.

- 1) Perform the daily checkout procedure as explained above.
- 2) Perform the initial checkout procedure (see page 9).
- 3) Calculate the separation distance (see page 6), and verify that the actuating devices are far enough away from the nearest hazard point. Relocate the actuating devices, if necessary.
- 4) Verify that the actuating devices are positioned to require the use of both hands for operation, and are protected from false or inadvertent operation.
- 5) Inspect the machine controls and the connections to the DUO-TOUCH Safety Module to ensure that wiring is correct, as described on pages 6 through 8, and that no modifications have been made which could adversely affect the System.

Qualified Person: A person who, by possession of a recognized degree or certificate of professional training, or who, by extensive knowledge, training, and experience, has successfully demonstrated the ability to solve problems relating to the installation, maintenance and use of the DUO-TOUCH Two-Hand Control Safety System.

Repairs

NOTE: Do not attempt any repairs to the DUO-TOUCH Two-Hand Control Module. It contains no field-replaceable components. Return it to the factory for warranty repair or replacement.

If it ever becomes necessary to return a DUO-TOUCH Safety Module to the factory, please do the following:

- 1) Contact the Banner Factory Application Engineering Group at the address or at the numbers listed at the bottom of the back page. They will attempt to troubleshoot the system from your description of the problem. If they conclude that a component is defective, they will issue an RMA (Return Merchandise Authorization) number for your paperwork, and give you the proper shipping address.
- 2) Pack the component carefully. Damage which occurs in return shipping is not covered by warranty.



WARNING ... Do Not Use System Until Checkouts Are Verified

If all of the described checks cannot be verified, the two-hand-control system must not be used until the problem has been corrected. Injury or death to personnel may result from attempts to use the machine under such conditions.





CAUTION ... Abuse of Module After Failure

If an internal fault has occurred and the Module will not reset, **do not tap, strike, or otherwise attempt to correct the fault by a physical impact to the housing.** An internal relay may have failed in such a manner that its replacement is required.

If the Module is not immediately replaced or repaired, multiple simultaneous failures may accumulate such that the safety function can not be guaranteed.

DUO-TOUCH[®] – Models AT-..M-2A Two-Hand Control Modules

Specifications

Supply Voltage and Current	<p>Model AT-AM-2A: 115V ac \pm 15% at 100 mA</p> <p>Model AT-BM-2A: 230V ac \pm 15% at 50 mA</p> <p>Model AT-FM-2A: 24V ac/dc \pm 15% at 250 mA</p>
Supply Protection Circuitry	Protected against transient voltages and reverse polarity (dc hookup is without regard to polarity)
Output Configuration (including Auxiliary N.C. output 51/52)	<p>Outputs (K1 and K2): two redundant (total of four) safety relay (forced-guided) contacts</p> <p>Contact ratings:</p> <p>Maximum voltage: 250V ac or 250V dc</p> <p>Maximum current: 4A ac or dc (resistive load)</p> <p>Maximum power: 1000 VA, 200 watts</p> <p>Mechanical life: 10,000,000 operations</p> <p>Electrical life: 100,000 cycles (typically @ 1.0 kVA switching power)</p> <p>NOTE: Transient suppression is recommended when switching inductive loads. Install suppressors across load. Never install suppressors across output contacts (see Warning on page 8).</p> <p>Auxiliary Monitor Output (K3): One non-safety relay contact</p> <p>Maximum switching voltage: 125V ac or dc</p> <p>Maximum switching current: 500 mA (resistive load)</p>
Contact Fuse Protection	6.3 A quick or 4 A slow
Output Response Time	25 milliseconds maximum
Input Requirements	Outputs from actuating devices must each be capable of switching 40 to 100 mA @ 12 to 18V dc.
Simultaneity Monitoring Period	300 milliseconds (typical) < 500 milliseconds under single-fault conditions
Status Indicators	<p>3 green LED indicators (see Figure 1):</p> <p>Power ON</p> <p>K1 energized</p> <p>K2 energized</p> <p>1 red LED indicator:</p> <p>Fault</p>
Housing	Polycarbonate. Rated NEMA 1 (IEC IP20)
Mounting	Mounts to standard 35 mm DIN rail track. Safety Module must be installed inside an enclosure rated NEMA 3 (IEC IP54), or better.
Vibration Resistance	10 to 55Hz @ 0.35 mm displacement per IEC 68-2-6
Operating Conditions	<p>Temperature: 0° to +50°C (+32° to 122°F)</p> <p>Maximum Relative Humidity: 90% @ +50°C (non-condensing)</p> <p>Heat Dissipation Considerations: See page 4.</p>
Dimensions	See Figure 6.
Safety Category	1 and 3 per ISO 13849-1; Type IIIA/B per ISO 13851 (EN574) (Dependent on hookup and installation of the hand controls)
Certifications	  

DUO-TOUCH® – Models AT-..M-2A Two-Hand Control Modules

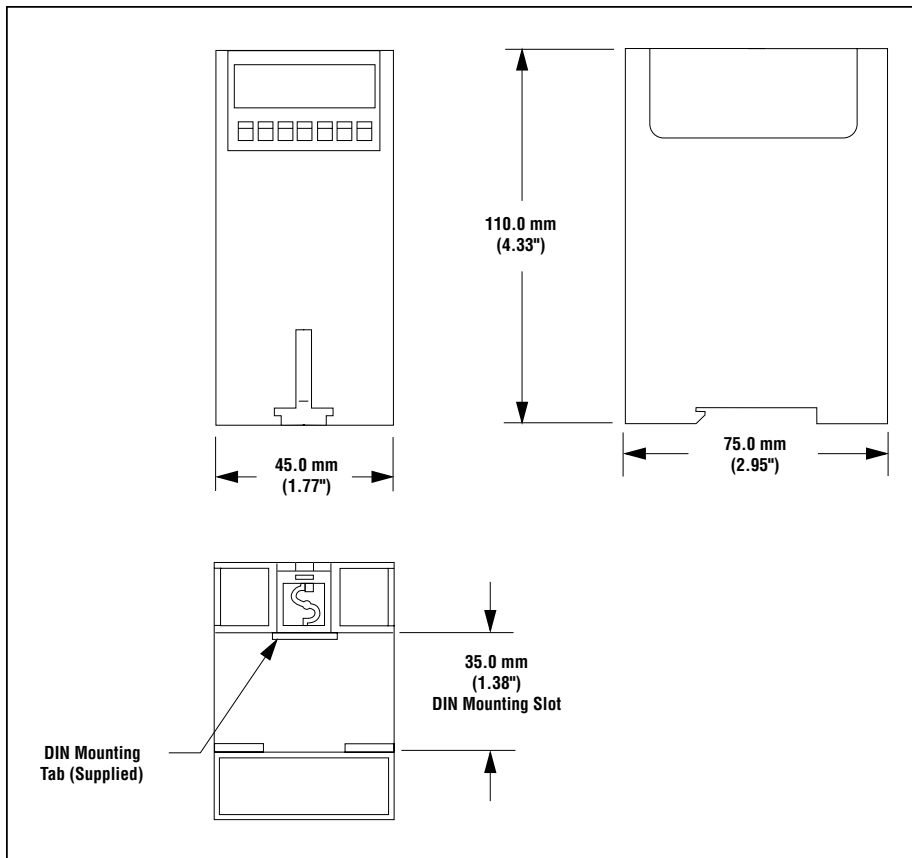

Figure 6. Module housing dimensions



WARRANTY: Banner Engineering Corp. warrants its products to be free from defects for one year. Banner Engineering Corp. will repair or replace, free of charge, any product of its manufacture found to be defective at the time it is returned to the factory during the warranty period. This warranty does not cover damage or liability for the improper application of Banner products. This warranty is in lieu of any other warranty either expressed or implied.