

### Features

- Safety Extension Module provides additional safety outputs for a Primary Safety Device (for example, an E-stop safety module or a two-hand control module)
- Features four delayed 6-amp switching channels for connection to control-reliable machine power interrupt circuits
- For use in functional controlled stop category 1 applications per NFPA 79 and EN418
- Contact status outputs are provided for connection to the Primary Safety Device's monitoring input
- 24V ac/dc operation
- Housed in a narrow, 22.5 mm (0.9") DIN-rail-mountable module
- Design complies with standards UL 991 and EN 60204

### Description

EM-FD-7G Series Safety Extension Modules provide additional forced-guided (positive-guided) relay contacts for a Primary Safety Device, such as an E-stop relay or a two-hand control module. Controlled by a safety output of the Primary Safety Device, the Extension Module provides four safety outputs. These outputs may be connected to control-reliable machine power interrupt circuits. Each of the four Extension Module safety outputs is a series connection of two forced-guided relay contacts.

The EM-FD-7G Series is available in three models with varying OFF delays:

Models	Delay OFF
EM-FD-7G2	0.5 Second
EM-FD-7G3	1 Second
EM-FD-7G4	2 Seconds

The safety outputs of the Safety Extension Module follow the action of the safety output from the Primary Safety Device which controls it, with a switching delay time as noted above. The output delay permits dynamic motor braking typical of variable frequency motor drives and servo motor controllers. The Extension Module's four safety outputs are each rated for up to 250V ac/dc at up to 6A.

The Safety Extension Module offers an output circuit at terminals Y1 and Y2 which provides K1 and K2 contact status information for connection to the monitoring input of the Primary Safety Device (see Figure 3). This monitoring circuit prevents the Primary Safety Device from being reset if contacts of either K1 or K2 of the Extension Module fail in a shorted condition.

The Safety Extension Module has indicators for input power (green), and status of internal relays (K1 and K2, both green) (see Figure 1). There are no adjustments and no user-serviceable parts. See page 6 for information regarding repair service.



**WARNING . . .**  
**These Safety Extension Modules are not point-of-operation guarding devices, as defined by OSHA regulations.** It is necessary to install point-of-operation guarding devices, such as safety light screens and/or hard guards, to protect personnel from hazardous machinery. **Failure to install point-of-operation guards on hazardous machinery could lead to serious injury or death.**



## **IMPORTANT NOTICE . . . Read this page before proceeding!**

Banner Engineering Corp. has made every effort to provide complete application, installation, operation, and maintenance instructions. In addition, any questions regarding the use or installation of this Banner Safety Extension Module should be directed to the factory applications department at the telephone numbers or addresses shown on the back cover.

The user shall ensure that all machine operators, maintenance personnel, electricians, and supervisors are thoroughly familiar with and understand all instructions regarding the installation, maintenance, and use of this Safety Extension Module, and with the machinery it controls.

The user and any personnel involved with the installation and use of this Safety Extension Module must be thoroughly familiar with all applicable ANSI/NFPA standards. The standards, listed below, directly address the use of Primary Safety Devices, by which the Extension Module can be controlled. Banner Engineering Corp. makes no claim regarding a specific recommendation of any organization, the accuracy or effectiveness of any information provided, or the appropriateness of the provided information for a specific application.

The user has the responsibility to ensure that all local, state, and national laws, rules, codes, and regulations relating to the use of this Safety Extension Module in any particular application are satisfied. Extreme care is urged that all legal requirements have been met and that all installation and maintenance instructions contained in this manual are followed.

### **U. S. Standards Applicable to Use of Primary Safety Devices**

ANSI B11	Standards for Machine Tools “Safety Requirements for the Construction, Care and Use” Available from: Safety Director AMT – The Association for Manufacturing Technology 7901 Westpark Drive McLean, VA 22101-4269 Tel.: 703-827-5266
NFPA 79	“Electrical Standard for Industrial Machinery (1997)” Available from: National Fire Protection Association 1 Batterymarch Park, P.O. Box 9101 Quincy, MA 02269-9101 Tel.: 800-344-3555
ANSI/RIA R15.06	“Safety Requirements for Industrial Robots and Robot Systems” Available from: Robotic Industries Association 900 Victors Way, P.O. Box 3724 Ann Arbor, MI 48106 Tel.: 734-994-6088

### **European Standards Applicable to Use of Primary Safety Devices**

EN 292-1	“Safety of Machinery – Basic Concepts, General Principles for Design Part 1: Basic Terminology, Methodology”
EN 292-2	“Safety of Machinery – Basic Concepts, General Principles for Design Part 2: Technical Principles and Specifications”
EN 60204-1	“Electrical Equipment of Machines: Part 1: General Requirements” Also, request a type “C” standard for your specific machinery.
EN 418	“Safety of Machinery – Emergency Stop Equipment Functional Aspects, Principles for Design” Available from: Global Engineering Documents 15 Inverness Way East Englewood, CO 80112-5704 Tel.: 800-854-7179

# Safety Extension Modules – EM-FD-7G Series with Delayed Output

## EM-FD-7G Series Specifications

<b>Supply Voltage and Current</b>	A1-A2: 24V ac/dc, +/-10%, 10% maximum ripple on dc
<b>Supply Protection Circuitry</b>	Protected against transient voltages and reverse polarity
<b>Output Configuration</b>	<p><b>Four output channels:</b> Each channel is a series connection of two forced-guided (positive-guided) safety relay contacts – AgSnO<sub>2</sub></p> <p><b>Contact ratings:</b>  <b>Maximum voltage:</b> 250V ac/dc  <b>Maximum current:</b> 6 A ac/dc (at specified operating temperature)  <b>Minimum current:</b> 30 mA @10V dc  <b>Maximum power:</b> 1500VA, 150 W  <b>Mechanical life:</b> 10,000,000 operations  <b>Electrical life:</b> 100,000 at full resistive load  <b>Feedback contact rating (Y1-Y2):</b> 250V ac/dc @ 3.0A</p> <p><b>NOTE: Transient suppression is recommended when switching inductive loads. Install suppressors across load. Never install suppressors across output contacts (see Warning, page 5).</b></p>
<b>Output Response Time</b>	<p><b>Delay OFF:</b> 0.5 sec ± 30% for model EM-FD-7G2, 1 sec ± 30% for model EM-FD-7G3, 2 sec ± 30% for model EM-FD-7G4, as measured from the time when the supply voltage to A1 is interrupted</p> <p><b>Delay ON:</b> 30 milliseconds for all models</p>
<b>Input Requirements</b>	Input from Primary Safety Device must be capable of switching 40 to 100mA @ 13 to 27V ac/dc.
<b>Status Indicators</b>	<p><b>3 green LED indicators:</b>  Power ON  K1 energized  K2 energized</p>
<b>Construction</b>	Polycarbonate housing.
<b>Environmental Rating</b>	Rated NEMA 1, IEC IP20. Safety Extension Module must be installed inside an enclosure rated NEMA 3 (IEC IP54), or better.
<b>Mounting</b>	Mounts to standard 35 mm DIN-rail track.
<b>Vibration Resistance</b>	10 to 55Hz @ 0.35 mm displacement per IEC 68-2-6
<b>Operating Temperature</b>	0° to +50°C (+32° to 122°F)
<b>Application Notes</b>	There are no adjustments and no user-serviceable parts. See page 6 for information regarding repair service.

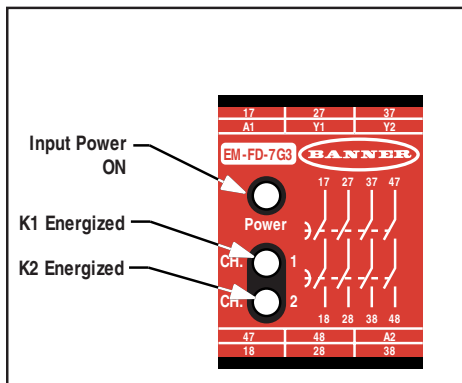

Figure 1. EM-FD-7G Series status indicators

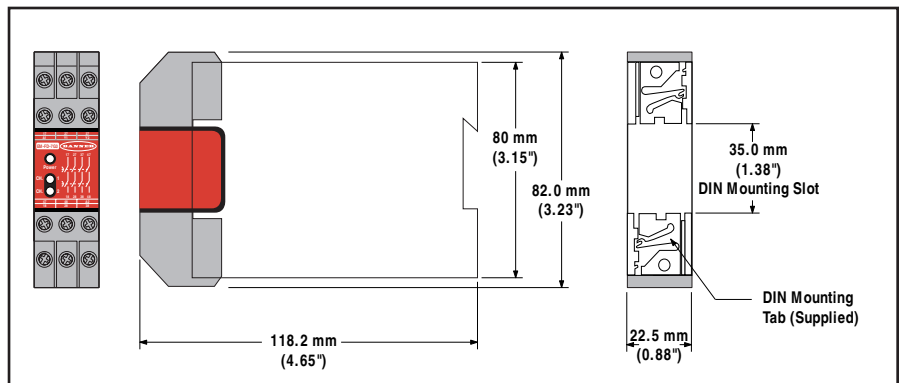

Figure 2. EM-FD-7G Series Safety Extension Module enclosure dimensions

# Safety Extension Modules – EM-FD-7G Series with Delayed Output

## Installation

### Primary Safety Device Requirements

An EM-FD-7G Series Safety Extension Module is driven by one safety output channel of a Primary Safety Device. The design of the Primary Safety Device must meet OSHA and ANSI control reliability requirements. **The EM-FD-7G Series module must be used only with a Primary Safety Device which has a dedicated input for feedback monitor contacts** (see hookup diagram, Figure 3).

The output channel of the Primary Safety Device must meet the following requirements:

- Include two (or more) redundant, normally open forced-guided (positive-guided) contacts,
- Be self-monitored to result in a safe (open) condition in the event of a contact failure, and
- Be capable of switching 40 to 100 mA at 13 to 27V ac/dc.

### Mechanical Installation

The EM-FD-7G Series Safety Extension Module must be installed inside an enclosure. It is not designed for exposed wiring. It is the user's responsibility to house the Extension Module in an enclosure with NEMA 3 (IEC IP54) rating, or better.

Dimensions of the Safety Extension Module are shown in Figure 2; it mounts directly to standard 35mm DIN rail.

### Electrical Installation

Because the Extension Module can be used with many different Primary Safety Devices and can interface to a multitude of machine control configurations, it is not possible to give exact wiring instructions for the output contacts. The following guidelines are general in nature.

The output contacts of the Extension Module have a delay function. They will open within the specified delay after the controlling contacts coming from the Primary Safety Device open.

Model	Delay OFF
EM-FD-7G2	0.5 second
EM-FD-7G3	1.0 second
EM-FD-7G4	2.0 seconds



#### WARNING . . . Possible OFF-Delay Failure

The delay outputs of EM-FD-FG Series Safety Extension Modules may open faster than the OFF-delays specified in the chart, due to a failure within the module. **In applications that require a specified OFF-delay (in order to operate a machine brake, for example), in which such a failure could result in a hazardous situation, the installation, including its wiring, must be designed to prevent such a hazard.**



#### WARNING . . . Not for Use As a Stand-Alone Safety Relay

- 1) **DO NOT connect E-stop switches, 2-hand control switches, safety interlock switches, or similar devices directly to this Extension Module.**
- 2) **ALWAYS connect terminals Y1 and Y2 of this Extension Module to the monitoring input of the Primary Safety Device that controls it (see Figure 3).**

This Safety Extension Module does not have the circuitry required to perform a self-check. A single fault inside the unit or in external devices like switches or E-stop buttons connected to the unit can go undetected and create an unsafe condition. **Failure to properly connect this Safety Extension Module to a control-reliable Primary Safety Device could result in serious injury or death.**



#### CAUTION . . . Dangerous Voltages

**Always disconnect all power from the Safety Extension Module, the Primary Safety Device, and from the machine being controlled before making any wire connections.** Electrical installation and wiring must be made by qualified personnel and must comply with the NEC (National Electrical Code), EN 60204-1 and -2, and all applicable local standards and codes.

# Safety Extension Modules – EM-FD-7G Series with Delayed Output



## WARNING . . . Use of Arc Suppressors

If arc suppressors are used, they **MUST** be installed as shown across the actuator coil of the master stop control elements (MSC1 to MSC4). **NEVER** install suppressors directly across the output contacts of the Safety Extension Module. It is possible for suppressors to fail as a short circuit. If installed directly across the output contacts of the Safety Extension Module, a short-circuited suppressor will create an unsafe condition which could result in serious injury or death.



## WARNING . . . Maintain Control Reliability

**NEVER** wire an intermediate device (e.g., a programmable logic controller/ PLC), other than a safety relay, between any safety output of the Safety Extension Module and the master stop control element it switches. To do so sacrifices the control reliability of the control-to-machine interface, and creates an unsafe condition which could result in serious injury or death. Whenever a safety relay is added as an intermediate switching device, a normally-closed forced-guided monitor contact of that relay must be added to the series feedback loop.

(Reference ANSI B11.1 – 1988, Appendix B4)

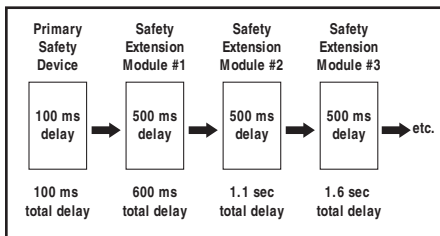

Figure 4. Figuring the total delay response of each Safety Extension Module in a multiple-module circuit

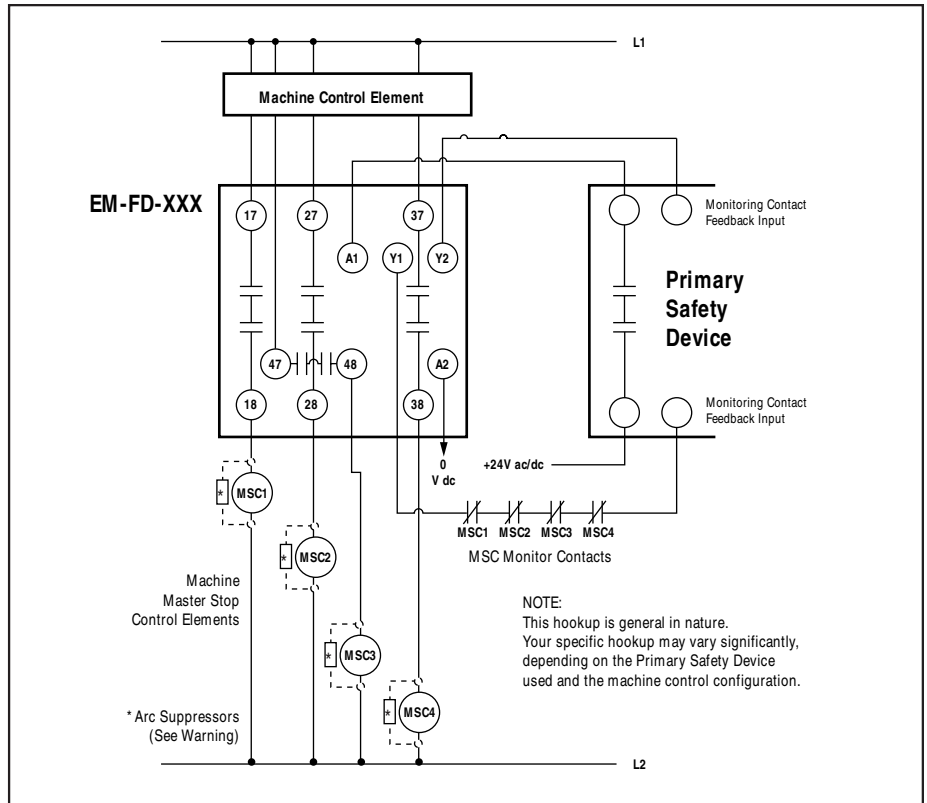

Figure 3. Generalized EM-FD-7G Series hookup

### One-Channel Control (Figure 3)

One-channel control affords simplicity of wiring. However, one-channel wiring requires eliminating the possibility of an unsafe failure of the control wires (which connect the output of the Primary Safety Device to the input of the Extension Module). One of the ways to reduce the probability of such failure is to locate the Primary Safety Device adjacent to the Safety Extension Module, in the same enclosure.

The output of the Primary Safety Device must consist of two or more series-connected, normally open contacts, coming from forced-guided safety relays. These contacts must be monitored for failure by the Primary Safety Device. In addition, a single contact failure cannot prevent normal stopping action, and a successive cycle cannot be initiated until the failure has been corrected. An example of this type of output is any single output channel of a Banner E-stop safety module.

### Use of Multiple Safety Extension Modules

Multiple Safety Extension Modules may be series-connected to provide additional output channels. However, the delay time of each Safety Extension Module must be added to the delay (or response) time(s) of the Primary Safety Device and all Safety Extension Modules ahead of it in the circuit to determine its total output response time (see Figure 4).

Whenever more than one Safety Extension Module is controlled by one Primary Safety Device, the monitoring contacts of all Safety Extension Modules (terminals Y1 and Y2) must be wired together in series and connected to the Monitoring Contact Feedback Input of the Primary Safety Device.

# Safety Extension Modules – EM-FD-7G Series with Delayed Output

## Connection to the Machine to be Controlled

Some machines, such as those using dynamic motor braking, require power to be provided during the braking action. EM-FD-7G Series Safety Extension Modules offer delayed OFF time to accomplish this type of controlled stop. This is a Category 1 Stop, per EN418 and NFPA 79.

The hookup diagram in Figure 3 shows a generic connection of the four safety output channels of the Safety Extension Module to Master Stop Control Elements MSC1 through MSC4. A Master Stop Control Element is defined as an electrically powered device, external to the Extension Module, which stops the machinery being controlled by immediately removing the electrical power to the machine and (when necessary) by applying braking to dangerous motion (reference ANSI B11.19, section 5.2: “Stop Control”). **To achieve control reliability, two redundant MSCs are required to control each machine hazard.**

To satisfy the requirements of control reliability, all MSCs must offer at least one normally closed forced-guided monitor contact. One normally closed monitor contact from each MSC is wired in series to the monitoring contact feedback input of the Primary Safety Device, as shown in Figure 3. In operation, if one of the switching contacts of any MSC fails in the shorted condition, the associated monitor contact will remain open. As a result, it will not be possible to reset the Primary Safety Device.

NOTE: To allow the Primary Safety Device to properly monitor the MSC feedback monitoring circuit, the installation’s total series resistance (wire and contact) must not exceed manufacturer’s specifications (typically 30Ω resistance). If this value is exceeded, the Primary Safety Device may not allow a reset of the System.

Many types of mechanisms are used to arrest dangerous machine motion. Examples include mechanical braking systems, clutch mechanisms, and combinations of brakes and clutches. Additionally, control of the arresting scheme may be hydraulic or pneumatic. As a result, an MSC may be one of several control types, including a wide variety of contactors and electromechanical valves. If your machine documentation leaves any doubt about the proper connection points for the Safety Extension Module output contacts, do not make any connections. Contact the machine builder for clarification regarding connection to the MSCs.

## NOTICE regarding MSCs

To achieve control reliability, two redundant Master Stop Control Elements (MSCs) are required to control each machine hazard. Each MSC must be capable of immediately stopping the dangerous machine motion, irrespective of the state of the other. Some machines offer only one primary control element. For such machines, it is necessary to duplicate the circuit of the single MSC to add a second MSC.

MSCs must offer at least one forced-guided auxiliary contact which is wired to the monitoring contact feedback input of the Primary Safety Device (see hookup diagram, Figure 3).



### **WARNING . . . Zero-speed detection circuitry is required for reverse current braking applications**

Applications which use reverse current braking require zero-speed detection circuitry to prevent the motor from starting in the reverse direction. This additional circuitry is necessary in situations where motor reversal may cause a machine hazard and/or machine damage. Model EM-FD-7Gx extension modules **DO NOT** provide zero-speed detection circuitry.



### **WARNING . . . MSC Monitoring**

**All Master Stop Control elements (MSCs), such as control relays, must be of forced-guided, captive contact design to allow the MSC Monitoring circuit to detect unsafe failures within the master stop control elements.** This monitoring extends the safe switching point of the Primary Safety Device and the EM-FD-7G Series Safety Extension Module to the MSC elements. For this monitoring to be effective, a minimum of two redundant MSCs are required to control each hazard. This is to detect the unsafe failure of one MSC (e.g., a welded contact), while stopping the hazard and preventing a successive machine cycle with the second MSC.

**If the MSCs are the last electrically controlled device generating the hazard (i.e., not relays or contactors) and they do not have forced-guided, captive contacts to monitor (such as a solenoid), then the customer must ensure that failure or fault of any single component of the MSCs will prevent a successive machine cycle and will not result in a hazardous situation.**

NOTE: MSC monitoring is also called external device monitoring (EDM), MPCE feedback, and relay backchecking.

# Safety Extension Modules – EM-FD-7G Series with Delayed Output



**CAUTION . . .**  
Disconnect Power Prior  
to Checkout

**Before performing the initial checkout procedure, make certain all power is disconnected from the machine to be controlled.**

Dangerous voltages may be present along the Safety Extension Module wiring barriers whenever power to the machine control elements is ON. **Exercise extreme caution whenever machine control power is or may be present.**

## Initial Checkout Procedure

NOTE: *The Safety Extension Module can be used safely only when its operation is controlled via an appropriate Primary Safety Device, connected to the Extension Module according to the wiring diagram shown in Figure 3.*

Checkout procedure:

- 1) Remove the power controlling (and switched by) the machine control elements (see Caution at right).
- 2) Verify that the Primary Safety Device which will be controlling the Safety Extension Module is operating correctly, according to its product documentation and manufacturer's recommendations.
- 3) Confirm proper connection of the Safety Extension Module to the controlling Primary Safety Device according to the wiring diagram (see Figure 3).
- 4) Verify that all four Safety Extension Module output contacts follow exactly the operation of the safety output contacts of the controlling Primary Safety Device, within the specified delay time, when the Primary Safety Device is operated according to its product documentation and manufacturer's recommendations.

## Periodic Checkout

The checkout procedure described on page 6 should be performed according to the intervals specified by the product documentation of the Primary Safety Device controlling this Safety Extension Module.

## Repairs

**Do not attempt any repairs to the EM-FD-7G Series Safety Extension Module. It contains no field-replaceable components.** Return the Safety Extension Module to the factory for warranty repair or replacement.

If it ever becomes necessary to return a Safety Extension Module to the factory, please do the following:

- 1) Contact the Banner Factory Application Engineering Group at the addresses or at the numbers listed at the bottom of page 8. They will attempt to troubleshoot the system from your description of the problem. If they conclude that a component is defective, they will issue an RMA (Return Merchandise Authorization) number for your paperwork, and give you the proper shipping address.
- 2) Pack the Safety Extension Module carefully. Damage which occurs in return shipping is not covered by warranty.

# Safety Extension Modules – EM-FD-7G Series with Delayed Output

---



**the machine safety specialist**

## Banner Engineering Corp Limited Warranty

Banner Engineering Corp. warrants its products to be free from defects in material and workmanship for one year following the date of shipment. Banner Engineering Corp. will repair or replace, free of charge, any product of its manufacture which, at the time it is returned to the factory, is found to have been defective during the warranty period. This warranty does not cover damage or liability for misuse, abuse, or the improper application or installation of the Banner product.

THIS LIMITED WARRANTY IS EXCLUSIVE AND IN LIEU OF ALL OTHER WARRANTIES WHETHER EXPRESS OR IMPLIED (INCLUDING, WITHOUT LIMITATION, ANY WARRANTY OF MERCHANTABILITY OR FITNESS FOR A PARTICULAR PURPOSE), AND WHETHER ARISING UNDER COURSE OF PERFORMANCE, COURSE OF DEALING OR TRADE USAGE.

This Warranty is exclusive and limited to repair or, at the discretion of Banner Engineering Corp., replacement. IN NO EVENT SHALL BANNER ENGINEERING CORP. BE LIABLE TO BUYER OR ANY OTHER PERSON OR ENTITY FOR ANY EXTRA COSTS, EXPENSES, LOSSES, LOSS OF PROFITS, OR ANY INCIDENTAL, CONSEQUENTIAL OR SPECIAL DAMAGES RESULTING FROM ANY PRODUCT DEFECT OR FROM THE USE OR INABILITY TO USE THE PRODUCT, WHETHER ARISING IN CONTRACT OR WARRANTY, STATUTE, TORT, STRICT LIABILITY, NEGLIGENCE, OR OTHERWISE.

Banner Engineering Corp. reserves the right to change, modify or improve the design of the product without assuming any obligations or liabilities relating to any product previously manufactured by Banner Engineering Corp.