

## E-Stop Safety Modules with Adjustable Delay

Models **ES-TN-1H5** with 0-20 second delay, **ES-TN-1H6** with 0-200 second delay



### Features

- Selectable Auto-Reset or monitored Manual Reset.
- Auto or manual power-up
- One- or two-channel feedback monitoring
- Monitors one dual-channel or one single-channel normally closed E-stop switch circuit for a contact failure or wiring fault (safety category 2 or 4, per EN954-1; see pages 5 and 6).
- 4 amp safety output contacts
- Removable terminal blocks
- Input monitoring circuit has diverse-redundant microprocessors
- Designed for use in functional stop Category 0 and 1 applications (per EN 60204-1 and NFPA79)
- Two immediate output switching channels (functional stop Category 0) and two delayed output switching channels (functional stop Category 1). Delay time is adjustable from 0-20 seconds or 0-200 seconds, depending on model.
- One auxiliary non-safety, normally closed immediate output and one auxiliary non-safety normally closed delayed output for status monitoring.



**WARNING . . .**  
**This Emergency Stop Safety Module is not a point-of-operation guarding device, as defined by OSHA regulations.** It is necessary to install point-of-operation guarding devices, such as safety light screens and/or hard guards, to protect personnel from hazardous machinery. **Failure to install point-of-operation guards on hazardous machinery can result in a dangerous condition which could lead to serious injury or death.**

# E-Stop Safety Modules with Adjustable Delay — Models ES-TN-1H5/-1H6



## **Important ... read this page before proceeding!**

Banner Engineering Corp. has made every effort to provide complete application, installation, operation, and maintenance instructions. In addition, any questions regarding the use or installation of this Banner Emergency Stop Safety Module should be directed to the factory applications department at the telephone numbers or address shown on back cover.

The user shall ensure that all machine operators, maintenance personnel, electricians, and supervisors are thoroughly familiar with and understand all instructions regarding the installation, maintenance, and use of this Emergency Stop Safety Module, and with the machinery it controls.

The user and any personnel involved with the installation and use of this model Emergency Stop Safety Module must be thoroughly familiar with all applicable ANSI/NFPA standards. The standards, listed below, directly address the use of emergency stop systems. Banner Engineering Corp. makes no claim regarding a specific recommendation of any organization, the accuracy or effectiveness of any information provided, or the appropriateness of the provided information for a specific application.

The user has the responsibility to ensure that all local, state, and national laws, rules, codes, and regulations relating to the use of this Emergency Stop Safety Module in any particular application are satisfied. Extreme care is urged that all legal requirements have been met and that all installation and maintenance instructions contained in this manual are followed.

### **U. S. Standards Applicable to Use of Emergency Stop Safety Modules**

ANSI B11	Standards for Machine Tools "Safety Requirements for the Construction, Care and Use" Available from: Safety Director AMT – The Association for Manufacturing Technology 7901 Westpark Drive McLean, VA 22101-4269 Tel.: 703-893-2900
NFPA79	"Electrical Standard for Industrial Machinery (1997)" Available from: National Fire Protection Association 1 Batterymarch Park, P.O. Box 9101 Quincy, MA 02269-9101 Tel.: 800-344-3555
ANSI/RIA R15.06	"Safety Requirements for Industrial Robots and Robot Systems" Available from: Robotic Industries Association 900 Victors Way, P.O. Box 3724 Ann Arbor, MI 48106 Tel.: 734-994-6088

### **European Standards Applicable to Use of Emergency Stop Safety Modules**

ISO/TR 12100-1 & -2 (EN292-1 & -2)	"Safety of Machinery – Basic Concepts, General Principles for Design Part 1: Basic Terminology, Methodology, and Part 2: Technical Principles and Specifications"
ISO 13849-1 (EN954-1)	"Safety of Machines: Safety Related Parts of Control Systems"
IEC/EN60204-1	"Electrical Equipment of Machines: Part 1: General Requirements" Also, request a type "C" standard for your specific machinery.
ISO 13850 (EN418)	"Safety of Machinery – Emergency Stop Equipment Functional Aspects, Principles for Design" Available from: Global Engineering Documents 15 Inverness Way East Englewood, CO 80112-5704 Tel.: 800-854-7179

# E-Stop Safety Modules with Adjustable Delay — Models ES-TN-1H5/-1H6

## Key to Categories

• **A Functional Stop Category (0, 1 or 2), per EN60204-1 and NFPA79**, refers to the type of stopping action required by the guarded machine in question. Some machines may be stopped safely, immediately following a stop command (removal of power); others, due to their high speed, mass or momentum, would run on following an immediate stop command. These machines require power to be provided to the guarded machine's braking system for a specified delay time, to effect a controlled stop.

**Category 0 Stop:** immediate removal of power, uncontrolled stop

**Category 1 Stop:** controlled stop with a delay before power is removed from guarded machine

**Category 2 Stop:** controlled stop with power left available to the guarded machine actuators

• **A Safety Category (B, 1, 2, 3 or 4), per EN954-1**, refers to "the performance of a safety related part of a control system (or circuit) with respect to the occurrence of faults..." Of the many factors involved when selecting an appropriate safety category, hazard analysis, risk assessment and risk reduction are among the most important. The level of risk is based on the severity of a potential harm and its probability of occurring, which is used to determine the appropriate performance of a control system or circuit. Typically, as described in Annex B of EN954-1, in cases where serious injury is possible:

- **Safety Category 2** would be selected only if exposure to a hazard is infrequent, and of a short duration.
- **Safety Category 4** would be selected if exposure to a hazard is frequent to continuous, or if exposure is for a long duration.

For more information, refer to standards EN954-1, EN418, NFPA 79, EN60204-1 and British Standard 5304:(1988).

## Overview

The purpose of an Emergency Stop Safety Module (E-Stop Safety Module) is to increase the control reliability of an emergency stop circuit. As indicated in Figures 2 and 3, the E-Stop Safety Modules described in this document are designed to monitor a 1-channel or 2-channel E-stop switch. A 2-channel E-stop switch has two electrically isolated contacts.

### ISO 13849-1 Safety Categories

Both contacts of a 2-channel E-stop switch are monitored by the Safety Module. If either input is short-circuited, the Safety Module cannot be reset, and the controlled machinery cannot be restarted, following actuation of the E-stop switch. Two-channel E-stop switches used with this Safety Module are suitable for Safety Category 4 applications, per European Standard ISO 13849-1 (EN954-1), of which Category 4 is the highest safety category.

Use of a 1-channel E-stop switch provides no input redundancy, and no ability for the Safety Module to monitor for input short circuits. One-channel E-stop switches used with this Safety Module are generally suitable only for Safety Category 2 applications, per ISO 13849-1 (EN954-1).

### IEC/EN60204-1 and NFPA79 Functional Stop Categories

In a functional Category 0 emergency stop circuit, the opening of either of the two E-stop switch contacts (or the one contact, if configured to 1-channel) immediately removes electrical power from the machine control elements, which react to stop hazardous machine motion and/or other machine hazards. This redundancy of stopping control offered by a two-pole E-stop switch is the first step towards control reliability in an emergency stop circuit.

A functional stop Category 1 emergency stop circuit is a controlled stop with power available to the machine actuators to achieve the stop and then removal of power when the stop is achieved. When a Category 1 stop function is used, final removal of power must be ensured by means of electromechanical switching devices.

Functional stop Category 1 stops are intended for use on machines where immediate removal of power would not stop the machine immediately because its high speed, high mass or momentum would cause the machine to run on. To stop such machines quickly and safely, electro-mechanical or electrical brake systems like DC-injection brakes or reverse current via the machine's actuators are commonly used.

The outputs of E-stop Safety Modules ES-TN-1H5 and -1H6 are two redundant normally open *immediate* safety contacts (each of which is a series of two forced-guided relay contacts, K1 and K2 in Figure 2), and two redundant normally open *delayed* contacts (also each a series of two forced-guided relay contacts, K3 and K4). The delayed contacts may be used in a functional stop Category 1 application.

# E-Stop Safety Modules with Adjustable Delay — Models ES-TN-1H5/-1H6

In addition to the safety contacts, the E-Stop Safety Module has one normally closed immediate auxiliary contact (from K1 and K2) and one normally closed delayed auxiliary contact (from K3 and K4) for status monitoring by a process controller.

All output contacts of the E-Stop Safety Module, the normally open and the normally closed, are rated for up to 250V ac/dc at up to 4 amps.

The E-Stop Safety Module also provides a necessary reset function. ANSI B11 and NFPA 79 standards require that a Reset routine be performed after returning the E-stop switch to its closed-contact position. This prevents the controlled machinery from restarting simply by closing the E-stop switch. Models ES-TN-1H5 and -1H6 may be configured for Automatic Reset via two DIP switches located inside the Module housing, under the front cover (see Figures 5 and 6). **Automatic Reset mode is useful for some automated processes. However, when Automatic Reset is used, an alternate means must be established to require a Reset routine after the E-stop switch is returned to its closed-contact position (see WARNING on page 9).**

This E-stop Safety Module complies with the following design standards:

- EN418 Emergency Stop Equipment - Functional Aspects, Principles for Design
- EN954-1 Safety of Machinery: Safety-related Parts of Control Systems Part 1: General Design Directives (Safety Category 4)
- EN292-2-1991 Safety of Machinery: Basic Concepts, General Principles for Design Part 2: Technical Principles and Specifications
- IEC 60204-1-1997 Safety of Machinery: Electrical Equipment of Machines Part 1: General Requirements

The Safety Module has indicators for input power (Power), internal faults (Fault), E-stop inputs (E-Stop), reset input (Reset), monitoring of feedback contacts (Monitor), immediate outputs (Out) and delayed outputs (Timed-Out); see Figure 1.

E-Stop Safety Modules ES-TN-1H5 and -1H6 have no user-serviceable parts. See page 16 for information regarding repair service.

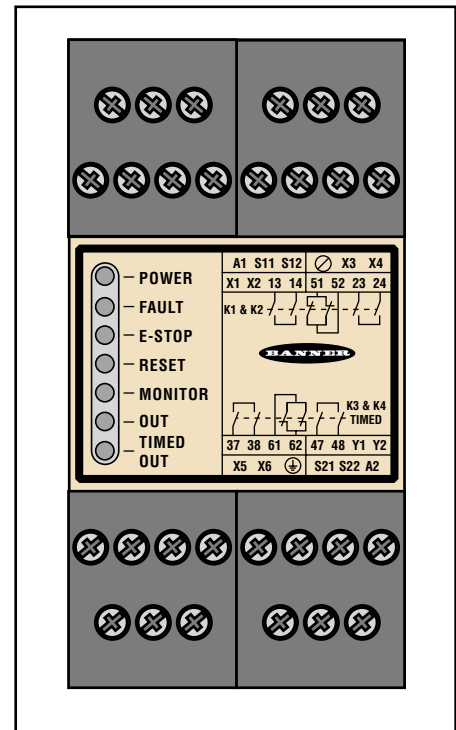

Figure 1. ES-TN-1H5 and -1H6 status indicators

# E-Stop Safety Modules with Adjustable Delay — Models ES-TN-1H5/-1H6

## E-Stop Switch Requirements

As shown in Figure 2, the E-stop switch must provide one or two contacts which are closed when the switch is armed. Once activated, the E-stop switch must open all its contacts, and must be returned to the closed contact position *only* by means of a deliberate action (such as twisting, pulling, or unlocking). The switch should be a “positive-opening type,” as described by IEC947-5-1. A mechanical force applied to such a button (or switch) is transmitted directly to the contacts, forcing them open. This ensures that the switch contacts will open whenever the switch is activated. NFPA 79 section 13.2, Emergency Stop Devices, specifies the following additional switch (“stop control”) requirements:

- Emergency Stop push buttons shall be located at each operator control station and at other operating stations where emergency shutdown shall be required.
- Stop and Emergency Stop push buttons shall be continuously operable from all control and operating stations where located.
- Actuators of Emergency Stop devices shall be colored RED. The background immediately around the device actuator shall be colored YELLOW. The actuator of a push-button-operated device shall be of the palm or mushroom-head type.
- The Emergency Stop actuator shall be a self-latching type.

NOTE: Some applications may have additional requirements. The user must refer to all relevant regulations.

If the Module is programmed for 1-channel E-stop (S11-S12), a jumper must be installed on the second channel (S21-S22) and configured for 1-channel input; see Figure 6.

When a 1-channel E-stop is used, the user must guard against failure modes that can result in an unsafe condition, for example the failure of the contact to a short circuit condition. A switch with positive opening operation should be used to reduce the possibility of a failure of the switch to open. A short circuit failure results in loss of switching function. This can occur from a short across the switch contacts, or a short across the wires connected to the switch somewhere between the switch and the E-Stop safety module. To reduce these possibilities, physically separate the wires from each other (e.g., in separate wireways or conduit).

According to the definition of European standard ISO 13849-1 (EN 954-1), a 1-channel E-stop should be used only in an application where Safety Category 2 or less (1 or B) has been determined via a risk-assessment procedure.

Two-channel E-stops, with positive open switches, are designed to issue a stop command even in the event of a single failure of this type and provide a high level of safety.

If the Module is programmed for 2-channel E-stop, the immediate normally open output contacts (13-14 and 23-24), will open and the normally closed auxiliary contact (51-52) will close as soon as at least one of the two E-stop contacts opens. The second contact, however, must open within 2 seconds of the first one; if not, the unit will go into a lockout condition that results in the outputs opening and requiring a reset after the fault has been corrected.



### **WARNING . . .** **1-Channel Input**

If a 1-channel E-stop button is used, a single fault (such as a short across the single E-stop contact or from the contact to a secondary source of power) can lead to the complete loss of safety.

**A 1-channel E-stop should be used only in applications where such a fault and the resulting loss of safety cannot result in serious injury or death.**

**If a 1-channel E-stop is used, separate the wires from each other by routing them through separate wireways or conduit in order to increase the reliability of the interface.**

# E-Stop Safety Modules with Adjustable Delay — Models ES-TN-1H5/-1H6

## Mechanical Installation

The E-stop Safety Module must be installed inside an enclosure. It is not designed for exposed wiring. It is the user's responsibility to house the E-Stop Safety Module in an enclosure with NEMA 3 (IEC IP54) rating, or better.

Dimensions of the Safety Module are shown in Figure 8, page 16. The Safety Module mounts directly to standard 35 mm DIN rail.

### Heat Dissipation Considerations

For reliable operation, the user must ensure that the operating specifications are not exceeded. The enclosure must provide adequate heat dissipation, so that the air closely surrounding the Module does not exceed the maximum operating temperature stated in the Specifications (page 15). Methods to reduce heat build-up include venting, forced airflow (e.g., exhaust fans), adequate enclosure exterior surface area, and spacing between modules and other sources of heat.

## Electrical Installation

It is not possible to give exact wiring instructions for a device such as an E-stop Safety Module which interfaces to a multitude of machine control configurations. The following guidelines are general in nature.

Models ES-TN-1H5 and -1H6 have two redundant immediate normally open supply output contacts (13-14 and 23-24), as well as two redundant delayed contacts (37-38 and 47-48). This qualifies this E-Stop Module to be used in applications as a functional stop Category 0 or 1 E-Stop Control as defined by NFPA 79 and ISO 13850 (EN 418).

NOTE: As the normally open immediate and delayed output contacts come from physically separate relays, an internal fault could cause only one set of contacts (either the immediate or the delayed) to close after a manual or auto reset. This possibility must be considered in the design of the machine control circuit.

## Connection of E-Stop Switch

Connect the poles of the E-stop switch as shown in Figure 3. The switch in Figure 3 is shown in the "armed" position with both contacts closed. Multiple E-stop switches connected to one E-stop Safety Module must be series connected (see Figure 2 and the warning on page 8).



### CAUTION . . . Shock Hazard

**Always disconnect power from the E-stop Safety Module and all power from the machine being controlled before making any wire connections.**

Electrical installation and wiring must be made by qualified personnel and must comply with the NEC (National Electrical Code), EN60204-1 and -2, and all applicable local standards and codes.

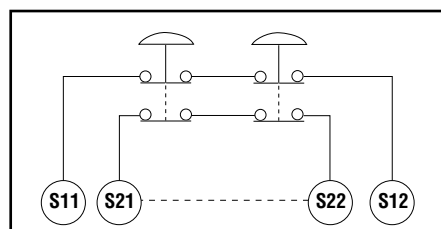

Figure 2. Series connection of multiple E-Stop switches. Jumper between S21 and S22, if 1-channel E-stop is selected.



### WARNING . . . Multiple E-Stop Switches

Whenever two or more E-stop switches are connected to the same E-Stop Safety Module:

- The contacts of both switches must be connected together in series. This series combination is then wired to the respective Safety Module input. **Never connect the contacts of multiple E-stop switches in parallel to the E-Stop Safety Module inputs; this defeats the switch contact monitoring ability of the Safety Module, and creates an unsafe condition.**
- Each switch must be individually actuated (engaged), then re-armed and the E-Stop Safety Module reset (if Manual Reset mode is selected). This allows the monitoring circuits to check each switch and its wiring to detect faults.

**Failure to do so could result in undetected faults and create an unsafe condition which could result in serious injury or death.**

# E-Stop Safety Modules with Adjustable Delay — Models ES-TN-1H5/-1H6



## WARNING . . . Wiring of Arc Suppressors

If arc suppressors are used, they **MUST** be installed as shown across the actuator coil of the Master Stop Control elements (MSC1 to MSC4). **NEVER** install suppressors directly across the output contacts of the E-Stop Safety Module. It is possible for suppressors to fail as a short circuit. If installed directly across the output contacts of the Safety Module, a **short-circuited suppressor will create an unsafe condition which could result in serious injury or death.**



## WARNING . . . Interfacing MSCs

**NEVER** wire an intermediate device (e.g., PLC, PES, PC) between E-Stop Safety Module outputs and the Master Stop Control Element it switches, in such a manner that:

- In the event of a failure there is a loss of the safety stop command, or,
- The safety function can be suspended, overridden, or defeated, unless accomplished with the same or greater degree of safety.

Whenever forced-guided, mechanically linked relays are added as intermediate switching devices, a normally closed forced-guided monitor contact from each relay must be added to the series feedback loop between Safety Module terminals X3 and X4 or X5 and X6.

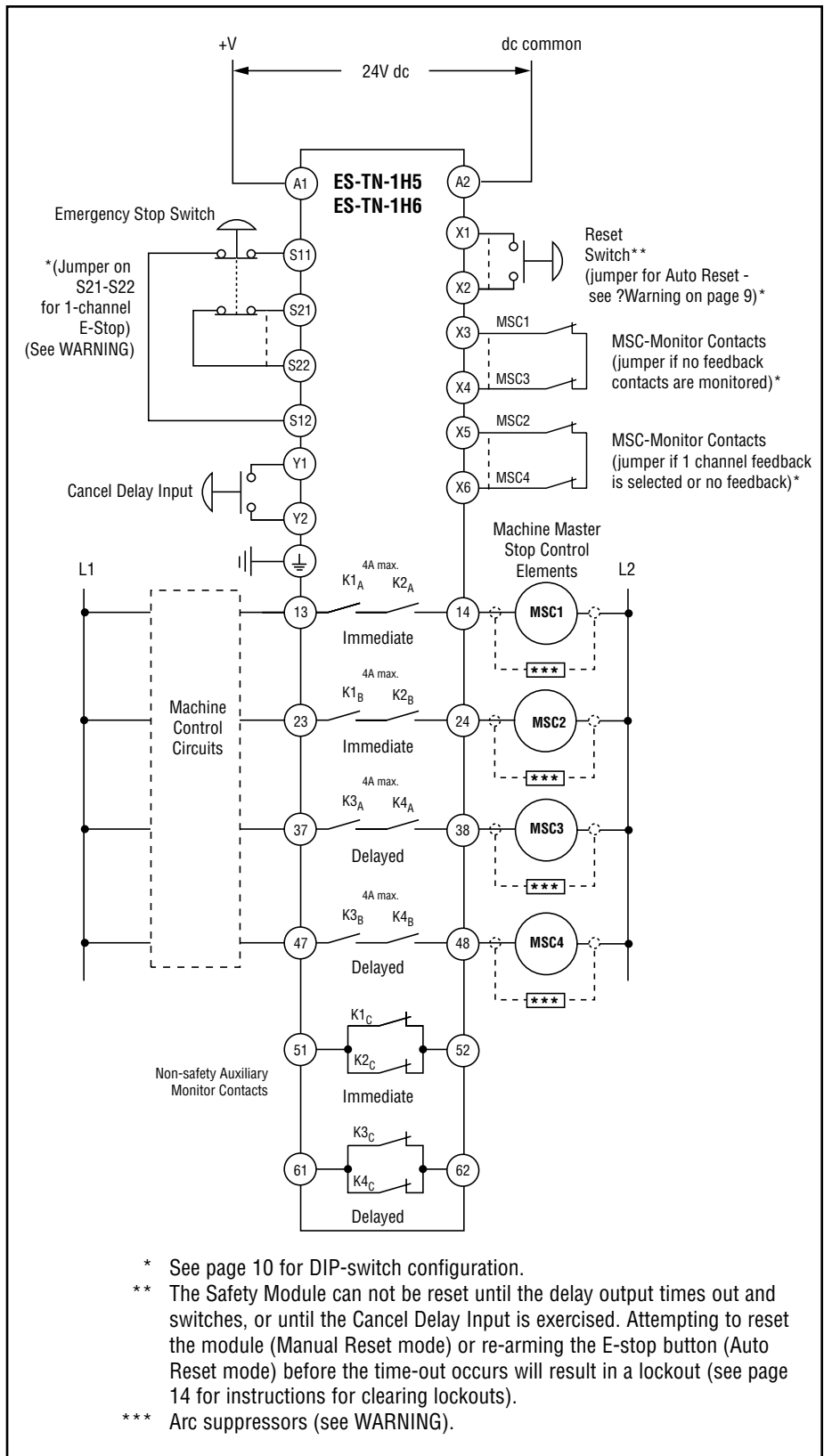

Figure 3. E-Stop Safety Modules ES-TN-1H5 and -1H6 hookups

# E-Stop Safety Modules with Adjustable Delay — Models ES-TN-1H5/-1H6

## Connection of Safety Switches

Models ES-TN-1H5 and ES-TN-1H6 may be used as a safety gate monitoring module. To achieve Safety Category 4 operation per EN954-1, two individually mounted, positive-opening safety switches that operate concurrently when the gate or guard is opened must be used (see Figure 4).

The ES-TN-1H5 and ES-TN-1H6 verify concurrent opening of two contacts – one from each safety switch. Reset of the Safety Module is not possible if one switch fails to open, or if a short circuit occurs between the safety switches or to dc common or to +24V.

Please contact the Banner Factory Applications Group at the numbers listed on the last page to discuss your intended use.

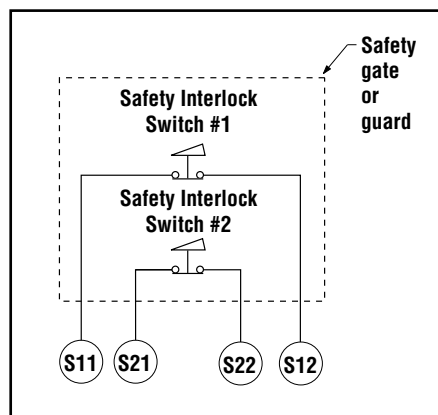

Figure 4. Hookup using contacts from two safety switches

## Connection of Reset Switch (Manual Monitored Reset)

The Reset Circuit switch can be any mechanical switch, such as a normally open momentary switch, or a two-position key switch. The Reset switch must be capable of reliably switching 18-30V dc at 10-25 mA. As shown in Figure 3, the Reset switch connects between terminals X1 and X2 of the Safety Module. A reset will occur after the Reset button goes from open, to closed, and back to open state.

**The Reset switch must be located outside of – and not be accessible from – the area of dangerous motion, and must be positioned so that any area of dangerous motion may be observed by the switch operator during the Reset procedure.**

## External Device Monitoring (EDM)

To satisfy the requirements of Safety Category 4 of EN 954-1, the Master Stop Control elements must each offer a normally closed, forced-guided monitor contact. For **2-channel monitoring**, one normally closed monitor contact from one Master Stop Control element, controlled by one of the immediate output contacts from the E-Stop Safety Module, is wired in series to one normally closed monitor contact from one Master Stop Control element, controlled by one of the delayed output contacts from the E-Stop Safety Module, to input X3-X4. The same configuration (one immediate N.C. series connected to one delayed N.C.) is wired to X5-X6 (Figure 3). In operation, if one of the switching contacts of any Master Stop Control (MSC) element fails in the shorted condition, the associated monitor contact will remain open, making reset of the E-Stop Safety Module impossible.

There is no specific feedback input to which the immediate MSCs must be connected. However, two immediate contacts (from two MSCs) or two delayed contacts (from two MSCs) should not be connected to the same input. If **1-Channel Monitoring** is selected, input X5-X6 must be jumpered, the Module configured for 1-Channel Monitoring (see Figure 3) and all monitoring contacts must be wired in series to X3 and X4. **See 1-Channel, 2-Channel, or No External Device Monitoring on page 10 for more information.**

## Connection to the Guarded Machine

The hookup diagram (Figure 3) shows a generic connection of the E-Stop Safety Module's four redundant output circuits to Master Stop Control elements MSC1 through MSC4. A Master Stop Control element is defined as an electrically powered device, external to the E-Stop Safety Module, which stops the machinery being controlled by immediately removing electrical power to the machine and (when necessary) by applying braking to dangerous motion. This stopping action is accomplished by removing power to the actuator coil of any Master Stop Control Element.

# E-Stop Safety Modules with Adjustable Delay — Models ES-TN-1H5/-1H6

## Configuration



### **WARNING . . . Reset Routine Required**

ANSI B11 and NFPA 79 standards require that a reset routine be performed after returning the E-stop switch to its closed-contact position (arming the E-stop switch). When Automatic Reset is used, an alternate means must be established to require a reset routine, after the E-stop switch is armed. **Allowing the machine to restart as soon as the E-stop switch is armed creates an unsafe condition which could result in serious injury or death.**



### **WARNING . . . Auto Power-Up and Momentary Power Loss**

If Auto Power-Up is selected, a momentary loss of power could cause the outputs to energize, even without a manual reset, when the power resumes. **Be sure that this Auto Power-Up situation does not cause the machine to restart, or an unsafe condition may occur that could result in serious injury or death.**

## Automatic Reset Mode

The E-Stop Safety Module may be configured for Automatic Reset via two independent DIP switches, located inside the Module housing, under the front cover (see Figures 5 and 6) and by replacing the Reset switch with a jumper wire in the X1-X2 reset input circuit (see Figure 3).

The E-Stop Safety Module will reset (and the outputs energize) as soon as the E-Stop switch returns to its closed-contact position (S11-S12 and S21-S22 closed), feedback inputs are closed (X3-X4 and X5-X6), and no fault exists. Automatic Reset will not occur if Manual Power-up is selected and the E-stop switch is already closed when power is applied.

Automatic reset mode is useful for some automated processes. **However, if Automatic Reset is used, it is necessary to provide a means of preventing resumption of hazardous machine motion, until an alternate reset procedure is performed.** The alternate procedure must include a Reset switch, located outside the area of dangerous motion, which is positioned so that any area of dangerous motion may be observed by the switch operator during the reset procedure.

NOTE: The minimum amount of time required for the Module to be in a STOP or OFF condition is 100 ms. This “recovery time” (OFF-state) is required for the internal circuitry of the Safety Module to normalize, allowing a reliable reset to occur. A lockout will occur if the Module is cycled too quickly. To clear the lockout, the Module must be re-cycled, meeting the minimum OFF time requirement.

## Auto Power-Up

If the Module is programmed for Auto Power-Up (see Figures 6 and 7), K1-K4 relays will close as soon as power is connected to A1-A2 – if the E-stop inputs S11-S12 and S21-S22 are closed, the appropriate jumpers are installed and feedback contacts X3-X4 and X5-X6 are closed, whether the Module is programmed for Auto or Manual Reset.

Auto Reset may be used only if the machine being controlled will not initiate dangerous motion if power is applied to or interrupted from the module. In addition, an alternate Reset routine must be required (see WARNING at left).

The next time the E-stop is cycled when the Module is set to Manual Reset, the Reset button at X1-X2 must go from open to closed and back to open in order to reset the unit and energize the four internal relays.

NOTE: Auto Power-Up in combination with Manual Reset energizes the output contacts automatically only one time after applying power to the Module. Cycling the E-stop button while power is applied *will not reset the unit.*

## Manual Power-Up

If the DIP switches are set to Manual Power-Up and Manual Reset, the unit will reset only after power is applied and the Reset button is pushed and released. If Manual Power-Up and Auto Reset is selected, the E-stop button must be cycled (opened and closed) if it is closed after power up (but simply closed if it is open after power-up).

# E-Stop Safety Modules with Adjustable Delay — Models ES-TN-1H5/-1H6

## Cancel Delay Input

The Cancel Delay Time input Y1-Y2 must be open during normal operation. After the E-stop button is activated (its contacts opened), and the delay time is running, a momentary closing of input Y1-Y2 will immediately terminate the delay time and open contacts 37-38 and 47-48, and close contact 61-62. A jumper between Y1-Y2 results in a Fault condition.

## External Device Monitoring Settings

### 1-Channel Monitoring

If 1-channel monitoring is selected (see Figure 6), one or more normally closed contacts from the MSCs must be wired to terminals X3-X4. If more than one contact is used, they must be wired in series (see Figure 3). The second channel (X5-X6) must be jumpered. The Module will reset only if both inputs are closed. After the unit is reset, the state of the X3-X4 input is irrelevant.

### 2-Channel Monitoring

If 2-channel monitoring is selected (see Figure 6), the Module will check both inputs X3-X4 and X5-X6 for closed state, before a reset can occur. After the unit is reset, and during RUN mode, both inputs will be checked for matching state. In other words, if one input opens, the other input must open within 200 milliseconds.

If both pairs of output contacts (both immediate and delayed) are used, and MSCs from all four contacts are controlled (Figure 3), both an immediate MSC and a delayed MSC contact must be connected in series to each of the two feedback inputs.

### No External Monitoring

If monitoring contacts are not required or if External Device Monitoring is not otherwise possible, jumper both X3-X4 and X5-X6 inputs and select 2-channel monitoring. **It is the responsibility of the user to ensure that any single failure will not result in a hazardous condition and will prevent a successive machine cycle.**



### CAUTION . . . Turn OFF Power Before Removing Cover

The front cover should only be removed and the switches set when no voltage is applied to terminals A1-A2. **Changing the position of the switches while power is ON could result in a Fault condition or a short circuit.**

# E-Stop Safety Modules with Adjustable Delay — Models ES-TN-1H5/-1H6

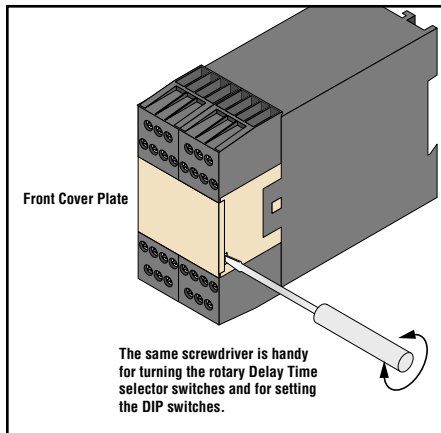

Figure 5. Use a screwdriver to gently pry the cover loose from the Module housing.

## DIP-Switch and Selector Switch Settings

The DIP switches and selector switches are located inside the Module housing, behind the front plate. Before adjusting any settings, turn OFF power to the Module. Remove the front plate by using a screwdriver in the slot on the right side and gently prying the cover away from the housing (Figure 5). Turn the rotary Delay Time selector switches to the desired position using the same small screwdriver in the slot on the arrow. Use the screwdriver blade to slide the DIP switches to their proper positions also.

The corresponding pairs of DIP switches and the two rotary Delay Time selector switches must match at all times, or a Fault condition will result. (If this occurs, turn the power OFF, adjust the pairs of switches to match, and turn the power supply back ON.) Figure 6 shows the DIP switches and Delay Time selector switches properly set for No Delay, Manual Reset, 1-Channel Monitoring, Manual Power-Up, and 2-Channel Input.

The E-Stop Safety Module factory settings are as follows:

Switch	Factory Setting	Optional Setting
<b>Manual/Auto Reset (S1, S1.1)</b>	0 – Manual reset	1 – Auto reset
<b>1-/2-Channel Monitoring (S2, S2.1)</b>	0 – 1-Channel Monitoring	1 – 2-Channel Monitoring
<b>Manual/Auto Power-Up (S3,S3.1)</b>	0 – Manual power-up	1 – Auto power-up
<b>2-/1-Channel E-Stop (S4, S4.1)</b>	0 – 2-Channel E-stop	1 – 1-Channel E-stop
<b>Delay Time Seconds* (T1, T2)</b>	0 – 0 Seconds	See table below

\*The amount of delay time between the opening of contacts 13-14 and 23-24, and contacts 37-38 and 47-48.

Optional settings for Delay Time (T1/T2) rotary switches (in seconds):

Switch Position	0	1	2	3	4	5	6	7	8	9	
ES-TN-1H5	0	0.5	1	2	4	6	8	10	15	20	Seconds
ES-TN-1H6	0	5	10	20	30	50	70	100	150	200	Seconds

**DIP AND SELECTOR SWITCH SETTINGS**  
(REMOVE COVER, FACTORY SETTINGS SHOWN)

**DELAY OFF TIME FOR CONTACTS**  
37 - 38, 47 - 48, 61 62.

9 0 1  
8 2  
7 3  
6 4  
5 4

0 = 0S  
1 = 0.5S  
2 = 1S  
3 = 2S  
4 = 4S

5 = 6S  
6 = 8S  
7 = 10S  
8 = 15S  
9 = 20S

9 0 1  
8 2  
7 3  
6 4  
5 4

↑ SWITCHES MUST MATCH TO OBTAIN DESIRED DELAY TIME.

S1 S2 S3 S4

S1.1 S2.1 S3.1 S4.1

	S1	S1.1	S2	S2.1	S3	S3.1	S4	S4.1
AUTO RESET	1	1						
MANUAL RESET	0	0						
2 CHANNEL MONITORING			1	1				
1 CHANNEL MONITORING			0	0				
AUTO POWER UP					1	1		
MANUAL POWER UP					0	0		
1 CH. INPUT							1	1
2 CH. INPUT							0	0

Figure 6. Module DIP switches and selectors, set to factory settings

**WARNING . . .**  
**Consequence of OFF-Delay Failure**

It is possible for any programmed OFF-delay timing function to fail, due to circuit failure or power loss, resulting in premature opening of the delay contacts. **The installation, including its wiring, must be designed to prevent any hazard which could result from the loss of a programmed output switching delay time.**

**WARNING . . .**  
**After Switch Configuration**

Follow the complete checkout and troubleshooting procedure (see page 12) following any change in the settings to the DIP switches or Time Delay Selector Switches.

# E-Stop Safety Modules with Adjustable Delay — Models ES-TN-1H5/-1H6

## Initial Checkout and Troubleshooting Procedure

**NOTE: If more than one E-Stop switch is series-connected to one E-Stop Safety Module, this checkout procedure must be run individually for each switch.**

1. Remove power from the machine being guarded and from the E-Stop Safety Module.
2. Activate the E-stop buttons (open their contacts).
3. Remove the E-Stop Safety Module front cover, (see Figure 5).
4. Check for correct settings on the DIP switches S1-S4 and S1.1-S4.1 (see Figure 6). The related pairs of switches (S1/S1.1, S2/S2.1, S3/S3.1, and S4/S4.1) must match at all times, as must the two Delay Time selector switches (T1/T2).
5. After switches are set to the proper position for the application, replace the E-Stop Safety Module front cover.
6. Make sure that jumpers, if required, are installed:  
**1-channel monitoring:** X5-X6                      **1-channel E-stop:** S21-S22  
**No monitoring:** X3-X4, X5-X6                      **Auto reset:** X1-X2
7. Turn the power ON to the E-Stop Safety Module. All LEDs will turn ON for a period of about 0.5 seconds, after which time all but the power LED will turn OFF for about 0.5 seconds; then the normal status indicator function will be displayed. If any LEDs do not cycle ON, then OFF after power is ON, disconnect power and check all wiring; return to step 5 after correcting the problem. If the problem cannot be corrected, return the Module to the factory for repair (see step 12 and page 16).
8. E-Stop LED will be OFF if the E-stop contacts are not closed. Out and Timed-Out LEDs must be OFF; Monitor LED must be ON (monitor inputs are closed). The Reset LED must be OFF if configured for Manual Reset, and ON if configured for Automatic Reset.
9. Arm the E-stop button.  
**If the Module is set for Auto Reset,** output contacts 13-14, 23-24, 37-38, and 47-48 should close immediately, and contacts 51-52 and 61-62 should open immediately. E-Stop, Out, and Timed-Out LEDs must all come ON.  
**If the Module is set for Manual Reset,** the E-Stop LED will come ON.  
After the E-Stop button is armed and the Reset LED starts flashing, reset the Module by closing and opening the reset input. (The Reset button should remain closed longer than 100 ms, but not longer than 2.5 seconds. The Reset LED will begin to flash again if the button is held in too long.) After Reset is opened, the Out and Timed-Out LEDs must come ON immediately. All normally open output contacts are closed now, and all normally closed output contacts are open. The Reset LED will be steady ON as long as the reset input is closed; it will go OFF if the reset input is opened and the four relays are ON.
10. Activate the E-Stop switch (open its contacts); the E-Stop LED must go OFF. Out LED must go OFF. Contacts 13-14 and 23-24 must open immediately; contact 51-52 will close immediately. Contacts 37-38 and 47-48 open after the selected delay time; contact 61-62 closes after the selected delay time. Timed-Out LED will go OFF after the delay time is over.
11. (Optional) Close the Cancel Delay input to immediately terminate the delay.
12. If the complete Safety Module must be replaced, the modular terminal strips may easily be removed for quick installation into another module. To remove the terminal strips, first replace the Safety Module front cover. Then insert the blade of a small screwdriver into one of the four depressions in the Safety Module front cover and pry them loose; see Figure 7.

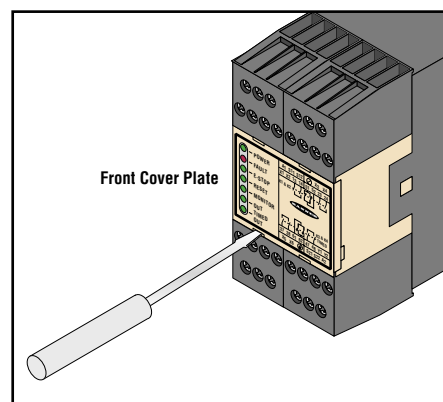

**Figure 7. To remove the Module's terminal strips, insert a small screwdriver blade into each of the four slots at the top and bottom of the front cover.**

# E-Stop Safety Modules with Adjustable Delay — Models ES-TN-1H5/-1H6



**CAUTION . . .**  
**Disconnect Power Prior**  
**to Checkout**

**Before performing the initial checkout procedure, make certain all power is disconnected from the machine to be controlled.** Dangerous voltages may be present along the E-stop Safety Module wiring barriers whenever power to the machine control elements is ON.  
**Exercise extreme caution whenever machine control power is or may be present. Always disconnect power to the machine control elements before opening the enclosure housing of the E-stop Safety Module.**

## Periodic Checkout Procedure

The functioning of the E-stop system must be verified periodically to ensure proper operation (see also the machine manufacturer's recommendations).

**NOTE: If two or more E-stop switches are series-connected to one E-Stop Safety Module, this test must be individually run for EACH switch.**

Procedure:

1. With the machine running, engage the E-stop switch (open its contact). Verify that the machine stops.
2. Return the E-stop switch to its closed-contact position. Verify that the machine does not restart.
3. Close and then open the Reset switch (if using manual reset mode). Verify that the machine restarts.

## LED Indicators

E-Stop Safety Modules ES-TN-1H5 and -1H6 provide seven indicator LEDs

<b>Power (green)</b>	ON – Power is connected to terminals A1-A2 OFF – No power or low power to terminals A1-A2, or internal power supply failure
<b>Fault (red)</b>	ON – External fault or configuration fault. The corresponding function LED (see below) will flash to indicate the area where the fault has been detected. See Fault Indication Table for probable cause. Flashing – Internal Fault. See page 16 for repair.
<b>E-Stop (green)</b>	ON – E-Stop inputs are closed (S11-S12 and S21-S22). OFF – E-Stop inputs are open. Flashing (Fault LED OFF) – If the Module is configured for Manual Power-up and Auto Reset, the E-Stop button must be cycled (opened, then closed) to enter RUN mode. (Ensure Cancel Delay input is open or a fault will occur.) Flashing (Fault LED ON) – See Fault Indication Table for probable cause.
<b>Reset (green)</b>	ON – Reset input is closed (X1-X2). OFF – Reset input is open. Flashing (Fault LED OFF) – “Reset Requested.” The Reset input (button) must be cycled (closed, then opened), to enter RUN mode. Flashing (Fault LED ON) – See Fault Indication Table for probable cause.
<b>Monitor (green)</b>	ON – Monitoring inputs are closed (X3-X4 and X5-X6). OFF – Monitoring inputs are open. Flashing (Fault LED ON) – See Fault Indication Table for probable cause.
<b>Out (green)</b>	ON – Both internal relays K1 and K2 are energized. (Immediate N.O. outputs 13-14 and 23-24 are closed. Immediate N.C. output 51-52 is open.) OFF – Both internal relays K1 and K2 are de-energized. (Immediate N.O. outputs 13-14 and 23-24 are open. Immediate N.C. output 51-52 is closed.)
<b>Timed-out (green)</b>	ON – Both internal relays K3 and K4 are energized. (Delayed N.O. outputs 37-38 and 47-48 are closed. Delayed N.C. output 61-62 is open.) OFF – Both internal relays K3 and K4 are de-energized. (Delayed N.O. outputs 37-38 and 47-48 are open. Delayed N.C. output 61-62 is closed.) Flashing (Fault LED ON) – See Fault Indication Table for probable cause.

# E-Stop Safety Modules with Adjustable Delay — Models ES-TN-1H5/-1H6

## Clearing Faults

To clear a fault condition, first correct the problem and then cycle the E-stop inputs to the module. When the Fault LED lights, the corresponding Function LED will flash to indicate the problem. If the Fault LED is flashing, refer to “Repairs,” on page 16.

LED	Indication	Fault and Probable Cause
POWER FAULT E-STOP RESET MONITOR OUT TIMED-OUT	ON ON FLASHING OFF ON or OFF OFF OFF	<b>E-Stop Input Fault</b> a) Jumper on S21-S22 missing if configured for 1-Channel E-Stop (S4/S4.1 = 1). b) Simultaneity fault on opening of E-Stop input channels (S11-S12 and S21-S22 must open within 2 seconds of each other). c) Short circuit between channels. d) E-Stop input short circuit to power or common.
POWER FAULT E-STOP RESET MONITOR OUT TIMED-OUT	ON ON ON or OFF FLASHING ON or OFF OFF OFF	<b>Reset Input Fault</b> a) Jumper on X1-X2 missing if configured for Auto Reset (S1/S1.1 = 1). b) Reset input short circuit to power or common. c) X1-X2 jumpered when configured for Manual Reset (S1/S1.1 = 0).
POWER FAULT E-STOP RESET MONITOR OUT TIMED-OUT	ON ON ON or OFF ON or OFF FLASHING OFF OFF	<b>Monitoring Input Fault</b> a) One or both monitoring inputs are open during reset. b) In 2-Channel Monitoring, inputs are not in the same state within 200 milliseconds of each other after the N.O. outputs close. c) In 1-Channel Monitoring, the X3-X4 input was not closed during reset. d) In 1-Channel Monitoring, the jumper on X5-X6 is missing.
POWER FAULT E-STOP RESET MONITOR OUT TIMED-OUT	ON FLASHING ON or OFF ON or OFF ON or OFF OFF OFF	<b>Internal Fault</b> a) Internal relay failure. b) Incorrect check sum. c) Other internal fault.
POWER FAULT E-STOP RESET MONITOR OUT TIMED-OUT	ON ON ON or OFF ON or OFF ON or OFF OFF OFF	<b>Configuration Fault</b> a) DIP switch blanks do not match. b) DIP switches changed while powered up. c) Time-delay rotary switches do not match. d) Time-delay rotary switches changed while powered up.  Cycle the power OFF, then ON to clear the fault.
POWER FAULT E-STOP RESET MONITOR OUT TIMED-OUT	ON ON FLASHING ON ON or OFF OFF FLASHING	<b>E-Stop Release Fault</b> a) In Auto-Reset, the E-Stop button was re-armed (closed) before Timed-out (K3-K4 de-energized).
POWER FAULT E-STOP RESET MONITOR OUT TIMED-OUT	ON ON ON ON or OFF ON or OFF OFF FLASHING	<b>Cancel Delay Input Fault</b> a) In Auto Reset mode, the E-Stop button was re-armed (closed) with cancel delay input closed. b) In Manual Reset mode, the E-Stop button was re-armed (closed) and the reset button pushed and released with cancel delay input closed.

# E-Stop Safety Modules with Adjustable Delay — Models ES-TN-1H5/-1H6

## Specifications

<b>Supply Voltage and Current</b>	24V dc, $\pm 20\%$ Power consumption: approx. 5 W												
<b>Supply Protection Circuitry</b>	Protected against transient voltages and reverse polarity												
<b>Output Configuration</b>	<p><b>Outputs K1 &amp; K2:</b> two redundant (total of four) safety relay (forced-guided) contacts – AgNi, gold flashed one auxiliary N/C contact – AgNi, gold flashed</p> <p><b>Outputs K3 &amp; K4:</b> two redundant (total of four) delayed relay (forced-guided) contacts – AgNi, gold flashed one auxiliary N/C contact – AgNi, gold flashed</p> <p><b>Contact ratings (all normally open and normally closed output contacts):</b>            Max. voltage: 250V ac or 250V dc            Max. current: 4 A ac or dc            Min. current: 30 mA @ 24V dc            Max. power: 1000VA, 100W            Mechanical life: 50,000,000 operations            Electrical life: 100,000 at full resistive load</p> <p><b>NOTE: Transient suppression is recommended when switching inductive loads. Install suppressors across load. Never install suppressors across output contacts (see Warning, page 6).</b></p>												
<b>Output Response Time</b>	<p><b>K1 &amp; K2:</b> 50 milliseconds typical</p> <p><b>K3 &amp; K4 (ES-TN-1H5):</b> 0, 0.5, 1, 2, 4, 6, 8, 10, 15, 20 seconds</p> <p><b>K3 &amp; K4 (ES-TN-1H6):</b> 0, 5, 10, 20, 30, 50, 70, 100, 150, 200 seconds</p> <p><b>Delayed Output Timing Tolerance:</b> Set time <math>\pm 100</math> ms or <math>\pm 2\%</math>, whichever is greater</p>												
<b>Input Requirements</b>	<p>E-stop switch must have normally closed contact capable of switching 20 mA @ 24V dc.            Reset switch must have one normally open contact capable of switching 20 mA @ 24V dc.</p> <p>NOTE: Inputs must be voltage-free, dry contacts.</p>												
<b>ON-Time Delay</b>	$\geq 100$ ms; time from the E-stop contacts to close (Auto Reset) or the Reset button to open (Manual Reset) and the safety outputs to close.												
<b>Status Indicators</b>	<table border="0"> <tr> <td colspan="2"><b>6 green LED indicators:</b></td> <td><b>1 red LED indicator:</b></td> </tr> <tr> <td>Power</td> <td>Monitor</td> <td>Fault</td> </tr> <tr> <td>E-Stop</td> <td>Out (K1 &amp; K2 ON/OFF)</td> <td></td> </tr> <tr> <td>Reset</td> <td>Timed-Out (K3 &amp; K4 ON/OFF)</td> <td></td> </tr> </table>	<b>6 green LED indicators:</b>		<b>1 red LED indicator:</b>	Power	Monitor	Fault	E-Stop	Out (K1 & K2 ON/OFF)		Reset	Timed-Out (K3 & K4 ON/OFF)	
<b>6 green LED indicators:</b>		<b>1 red LED indicator:</b>											
Power	Monitor	Fault											
E-Stop	Out (K1 & K2 ON/OFF)												
Reset	Timed-Out (K3 & K4 ON/OFF)												
<b>Housing</b>	Polycarbonate. Rated NEMA 1; IEC IP40, Terminals IP20, max. terminal torque 0.8 Nm												
<b>Mounting</b>	Mounts to standard 35 mm DIN rail track. Safety Module must be installed inside an enclosure rated NEMA 3 (IEC IP54), or better.												
<b>Vibration Resistance</b>	10 to 55Hz @ 0.35 mm displacement per IEC 68-2-6												
<b>Operating Conditions</b>	<p><b>Temperature:</b> 0° to +50°C (+32° to 122°F)</p> <p><b>Maximum Relative Humidity:</b> 90% @ +50°C (non-condensing)</p> <p><b>Heat Dissipation Considerations:</b> See page 7.</p>												
<b>Dimensions</b>	See Figure 8.												

# E-Stop Safety Modules with Adjustable Delay — Models ES-TN-1H5/-1H6

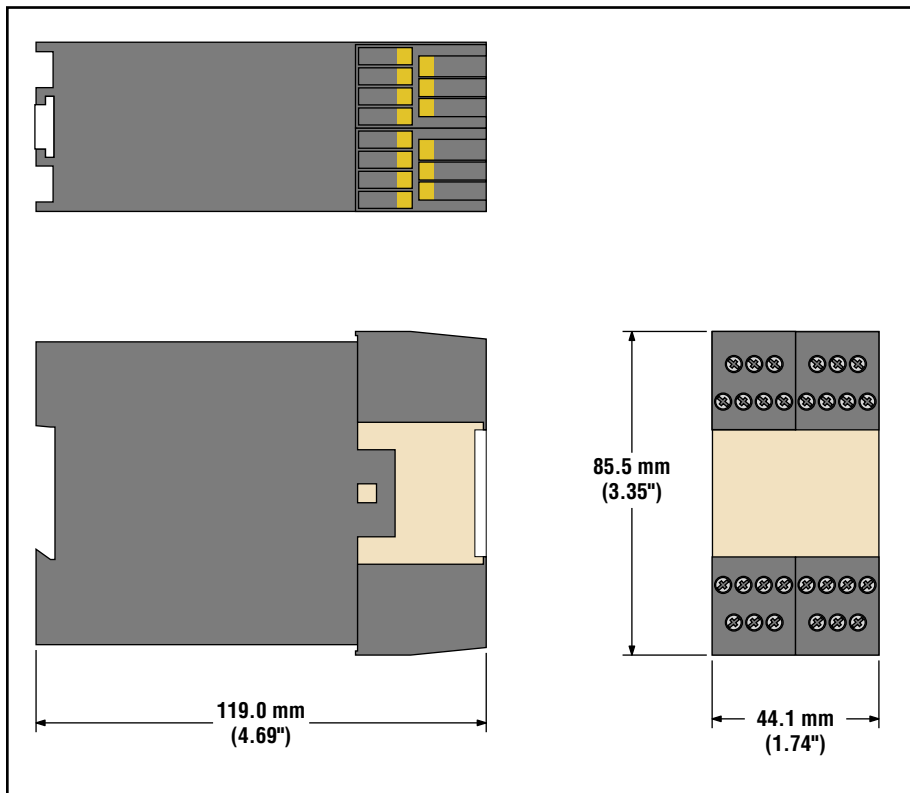

Figure 8. E-Stop Safety Modules ES-TN-1H5 and ES-TN-1H6 enclosure dimensions

## Repairs

**NOTE: Do not attempt any repairs to the ES-TN-1H5 or 1H6 Emergency Stop Safety Module. It contains no field-replaceable components. Return the Safety Module to the factory for warranty repair or replacement.**

If it ever becomes necessary to return an E-Stop Safety Module to the factory, please do the following:

- 1) Contact the Banner Factory Application Engineering Group at the address or at the numbers listed below. They will attempt to troubleshoot the system from your description of the problem. If they conclude that a component is defective, they will issue an RMA (Return Merchandise Authorization) number for your paperwork, and give you the proper shipping address.
- 2) Pack the E-Stop Safety Module carefully. Damage which occurs in return shipping is not covered by warranty.



### **WARNING . . . Abuse of Module After Failure**

If an internal fault has occurred and the Module will not reset, **do not tap, strike, or otherwise attempt to correct the fault by a physical impact to the housing.** An internal relay may have failed in such a manner that its replacement is required.

**If the Module is not immediately replaced or repaired, multiple simultaneous failures may accumulate such that the safety function can not be guaranteed.**



# Banner Engineering Corp Limited Warranty

---

Banner Engineering Corp. warrants its products to be free from defects in material and workmanship for one year following the date of shipment. Banner Engineering Corp. will repair or replace, free of charge, any product of its manufacture which, at the time it is returned to the factory, is found to have been defective during the warranty period. This warranty does not cover damage or liability for misuse, abuse, or the improper application or installation of the Banner product.

**THIS LIMITED WARRANTY IS EXCLUSIVE AND IN LIEU OF ALL OTHER WARRANTIES WHETHER EXPRESS OR IMPLIED (INCLUDING, WITHOUT LIMITATION, ANY WARRANTY OF MERCHANTABILITY OR FITNESS FOR A PARTICULAR PURPOSE), AND WHETHER ARISING UNDER COURSE OF PERFORMANCE, COURSE OF DEALING OR TRADE USAGE.**

This Warranty is exclusive and limited to repair or, at the discretion of Banner Engineering Corp., replacement. **IN NO EVENT SHALL BANNER ENGINEERING CORP. BE LIABLE TO BUYER OR ANY OTHER PERSON OR ENTITY FOR ANY EXTRA COSTS, EXPENSES, LOSSES, LOSS OF PROFITS, OR ANY INCIDENTAL, CONSEQUENTIAL OR SPECIAL DAMAGES RESULTING FROM ANY PRODUCT DEFECT OR FROM THE USE OR INABILITY TO USE THE PRODUCT, WHETHER ARISING IN CONTRACT OR WARRANTY, STATUTE, TORT, STRICT LIABILITY, NEGLIGENCE, OR OTHERWISE.**

Banner Engineering Corp. reserves the right to change, modify or improve the design of the product without assuming any obligations or liabilities relating to any product previously manufactured by Banner Engineering Corp.

