

R-GAGE QT50R-RH Sensor

Radar-Based Retroreflective Sensors for Detection of Moving and Stationary Targets

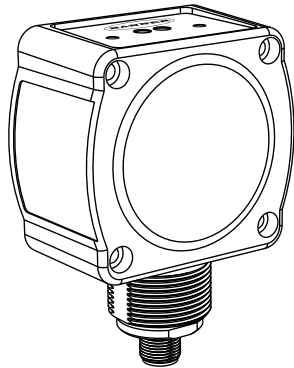

Features

- FMCW (true-presence) radar detects moving and stationary objects
- Retro-wave sensor - use of a reference signal (retroreflective target) enables reliable detection of weak targets in the foreground
- Retro-wave detection - output activates for objects detected in the foreground OR for loss of detection of the retroreflective target
- Easy setup and configuration of range, sensitivity, and output with simple DIP switches
- Ignores objects in the background beyond the retroreflective target
- Double reflection immunity technology
- Sensing field is configured via remote TEACH
- Sensing functions are unaffected by wind, falling rain or snow, fog, humidity, air temperatures, or light
- Sensor operates in Industrial, Scientific, and Medical (ISM) telecommunication band; no special license required
- Rugged IP67 housing withstands harsh environments

Protected by US patents

Models

Models ¹	Maximum Range	Connection	Supply Voltage	Telecom Approval ²	Output
QT50R-US-RH	12 m (39 ft)	5-wire 2 m (6.5 ft) Integral cable	12 to 30V dc	Telecom approved for US, Canada and Brazil	Bipolar NPN/PNP DIP-switch-selectable N.O. or N.C.
QT50R-EU-RH				Telecom approved for Europe (except UK), Australia, New Zealand, China, and Japan	
QT50R-UK-RH				Telecom approved for UK	



CAUTION: Make No Modifications to this Product

Any modifications to this product not expressly approved by Banner Engineering could void the user's authority to operate the product. **Contact the Factory for more information.**



WARNING: Not To Be Used for Personnel Protection

Never use this device as a sensing device for personnel protection. Doing so could lead to serious injury or death. This device does NOT include the self-checking redundant circuitry necessary to allow its use in personnel safety applications. A sensor failure or malfunction can cause either an energized or de-energized sensor output condition.

¹ Cabled models only are listed. For integral 5-pin Euro-style (M12) quick-disconnect fitting, add suffix "Q" to the model number (for example, QT50R-xx-RHQ). QD models require a mating cordset; see [Quick Disconnect \(QD\) Cordsets](#) on page 7.

² For additional countries, contact Banner Engineering.

Overview

The R-GAGE sensor emits a well-defined beam of high-frequency radio waves from an internal antenna. This emitted energy reflects off of a retroreflective target and returns to the receiving antenna. As long as the antenna is receiving reflected radio waves, the output will remain off. If an object blocks radio waves, the output will turn on. The distance range for the retroreflective target can be configured via remote TEACH wire. Objects beyond the retroreflective target are ignored (also called background suppression). In Normally Closed mode, the output operates like a foreground suppression sensor.

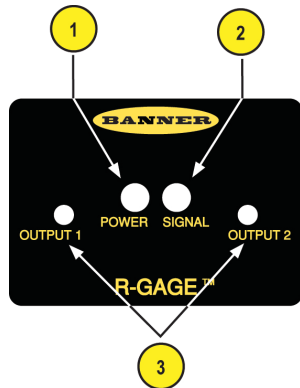

1. Power LED: Green (power ON)
2. Signal Strength LED: Red (flashes in proportion to signal strength)
3. Output LEDs: Yellow (output energized); Red (configuration)

Access DIP switches behind threaded cap on sensor back (not shown)

Figure 1. R-Gage Features

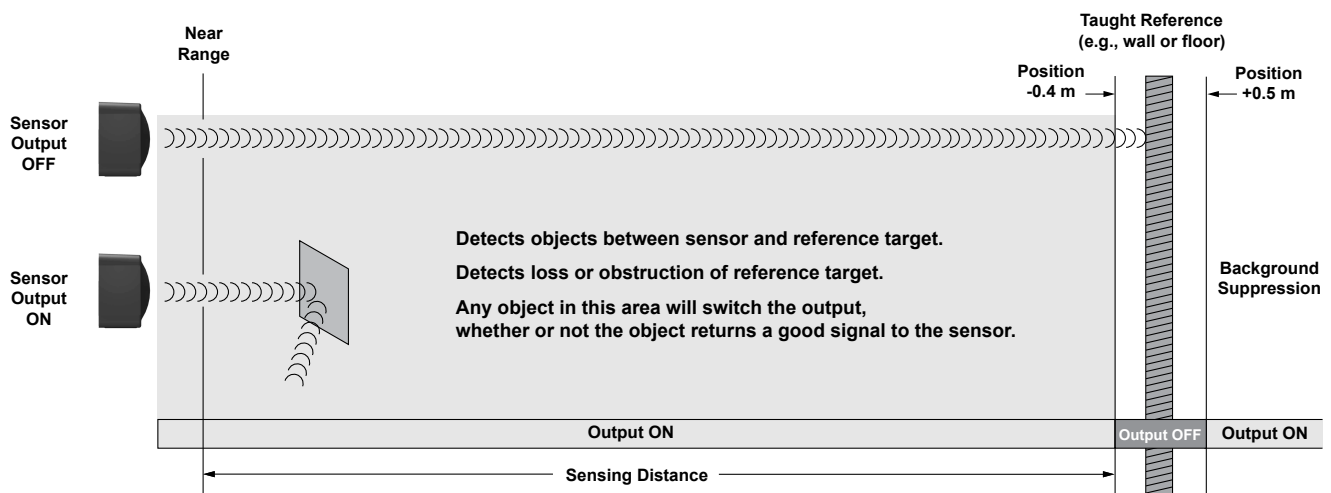

Figure 2. Sensor detects radio waves reflected from corner cube reflector or background. Any object blocking the signal results in an output change

Sensor Configuration

The sensitivity, and output configuration can be selected via the DIP switches on the back of the sensor. Use the included spanner to open the screw-off cover on the back of the sensor and access the DIP switches.



Important: Tighten the DIP switch cover a full quarter turn after contact to maintain the watertight seal.

DIP Switch Functions

Switch	Function
1, 2, 3	Retro Sensitivity (contrast between retroreflective target and foreground targets)

Switch	Function
4, 5	Foreground Sensitivity (improve detection of near-field mirror-like targets)
6	Normally open/normally closed output functionality
7, 8	Response Speed

DIP switch 1 is on the left and DIP switch 8 is on the right.

Retro Sensitivity Selection

* Default settings

Switch 1	Switch 2	Switch 3	Sensitivity	Contrast
0	0	0	8	Use for weak retro with strong targets ↓
0	0	1	7	
0	1	0	6	
0*	1*	1*	5*	Use for normal retro with normal targets
1	0	0	4	↓
1	0	1	3	
1	1	0	2	
1	1	1	1	Use for strong retro with weak targets

Foreground Sensitivity/Double Reflection Immunity

* Default settings

If a radar sensor encounters a mirror-like target in the near field, for example, the roof of a vehicle, it is possible for the sensor to detect the radio waves from the ceiling or wall behind the sensor that are being reflected by the target. The target object may not be detected in this type of situation. Typically, this is only an issue on top-down target detection when the sensor is mounted directly to a metal ceiling.

The Foreground Sensitivity DIP switch settings alleviate double reflections (mirror reflections). These settings are similar to secondary echo rejection in ultrasonic sensors. Set the Foreground Sensitivity DIP switch to Highest for best performance in top-down metal ceiling-mounted vehicle detection applications.

However, if there are strong reflections from peripheral objects within the full beam pattern of the sensor, the Highest setting may cause unwanted detection of the peripheral objects. In this case, set the Foreground Sensitivity DIP switch to Medium. Foreground sensitivity is designed for double reflections, not for strong peripheral reflections. When peripheral reflections are too strong, determine whether eliminating double reflections or peripheral reflections is more important. Depending on the decision, the foreground sensitivity may be turned to low when strong peripheral reflections are detected.

The Foreground Sensitivity DIP switch has four settings ranging from highest to low. The factory default setting is low.

Switch 4	Switch 5	Sensitivity	Use
0	0	Highest	Mirror targets (double reflections) with no peripheral reflections (widest effective beam pattern)
0	1	High	
1	0	Medium	Mirror targets (double reflections) with weak peripheral reflections that need to be ignored
1*	1*	Low	Strong peripheral reflections that need to be ignored (narrowest effective beam pattern). Double reflection immunity is disabled.

Output Configuration

* Default settings

Switch 6	Normally Open/Normally Closed
0*	N.O.
1	N.C.

Response Speed

* Default settings

Switch 7	Switch 8	ON (ms)	OFF (ms)	Total (ms)
0	0	30	70	100
0	1	30	120	150
1*	0*	50	300	350
1	1	50	600	650

Installation



For optimal performance, the sensor should be aimed perpendicular to the surface of the retroreflective target. Angling the sensor greater than 15 degrees with respect to a flat surface is not recommended.

The retroreflective target must be the strongest target in the field of view. If another equally strong background target is in the field of view, the sensor may be taught the wrong target, or the sensing state may oscillate.

After installing, a remote TEACH must be performed to teach the sensor the retroreflective target. The sensor will not operate correctly until a TEACH is performed. A TEACH must be performed each time the sensor is moved or the retroreflective target changes.

Remote Line TEACH

The adjustable field, retroreflective target, and background suppression distances are set using a remote wire. For remote programming, connect a switch or digital input to the gray wire (remote line); length of the individual pulses is equal to the value **T: 0.064 seconds < T < 0.8 seconds**

Step	Procedure	Result
Access Remote Line Teach	<ul style="list-style-type: none"> Double-pulse the remote line 	Output LEDs ON Red
Teach Distance	<ul style="list-style-type: none"> Single-pulse the remote wire 	Output 1 LED flashes Red 10x
Return to Run Mode	If the TEACH is successful, the sensor will be in a non-sensing state (output LEDs OFF)	Output LEDs OFF



NOTE: A successful TEACH can be verified by placing an object in between the sensor and the retroreflective target after the TEACH has been performed. This should cause both Output LEDs to turn ON.

Specifications

Range

The sensor is able to detect a proper retroreflective target (see Detectable Objects) up to 12 m (39.4 ft), depending on target

Detectable Objects

Objects containing metal, water, or similar high-dielectric materials

Operating Principle

Frequency modulated continuous-wave (FMCW) radar

Operating Frequency

24.00 to 24.25 GHz, ISM Band (varies slightly with model, depending on national telecom regulations)

Supply Voltage

12 to 30V dc, less than 100 mA, exclusive of load

Supply Protection Circuitry

Protected against reverse polarity and transient over-voltages

Delay at Power-up

Less than 2 seconds

Output Configuration

Bipolar NPN/PNP output, 150mA; DIP switch 6 selects N.O. (default) or N.C. operation

Output Protection

Protected against short circuit conditions

Response Time

DIP switches 7 & 8 select ON/OFF response time

Indicators

Power LED: Green (power ON)

Signal Strength LED: Red, flashes in proportion to signal strength. Steady on at 4x excess gain. Only indicates signal amplitude, not target distance.

Output LEDs: Yellow (output energized) / Red (configuration)

See [Figure 1. R-Gage Features](#) on page 2

Adjustments

DIP-switch-configurable sensitivity, response time, and output configuration; remote line teach of the retroreflective target

Construction

Housing: ABS/polycarbonate

Lightpipes: Acrylic

Access Cap: Polyester

Operating Temperature

-40° to +65° C (-40° to +149° F)

Environmental Rating

IP67

Connections

Integral 5-wire 2 m (6.5 ft) cable or M12 Euro-style QD fitting. QD models require a mating cordset

Certifications

CE

ETSI/EN 300 440; FCC part 15; RSS-210; ANATEL Category II; CMII Category G; ARIB STD T-73; for others, contact Banner Engineering.

FCC ID: UE3QT50RUS—This device complies with Part 15 of the FCC Rules. Operation is subject to the following two conditions: (1) this device may not cause harmful interference, and (2) this device must accept any interference received, including interference that may cause undesired operation.



Este equipamento opera em caráter secundário, isto é, não tem direito à proteção contra interferência prejudicial, mesmo de estações do mesmo tipo e não pode causar interferência a sistemas operando em caráter primário.

Windows

The R-GAGE sensor can be placed behind a glass or a plastic window, but the configuration must be tested and the distance from the sensor to the window must be determined and controlled prior to installation. There is typically a 20% signal reduction when the sensor is placed behind a window.

Polycarbonate at 4 mm thickness performs well in most situations, but the performance depends on filler materials. Thinner (1 to 3 mm) windows have high reflection. The amount of reflection depends on the material, thickness, and distance from the sensor to the window.

Locate the sensor in a position of minimum reflection from the window, which will repeat every 6.1 mm of distance between the sensor and the window. The positions of maximum reflection from the window repeat between the minimums, and decrease in effect until the window is approximately 150 mm (5.9 in) away. Consult the factory for pre-tested window materials which can be used at any distance without issue.

Additionally, the face of the window should be protected from flowing water and ice by use of a flow diverter or hood directly above the window. Falling rain or snow in the air in front of the window, light water mist, or small beads on the face of the window are typically not an issue. However, a thick, continuous surface of water or ice directly on the face of the window can be detected as a dielectric boundary.

Beam Patterns

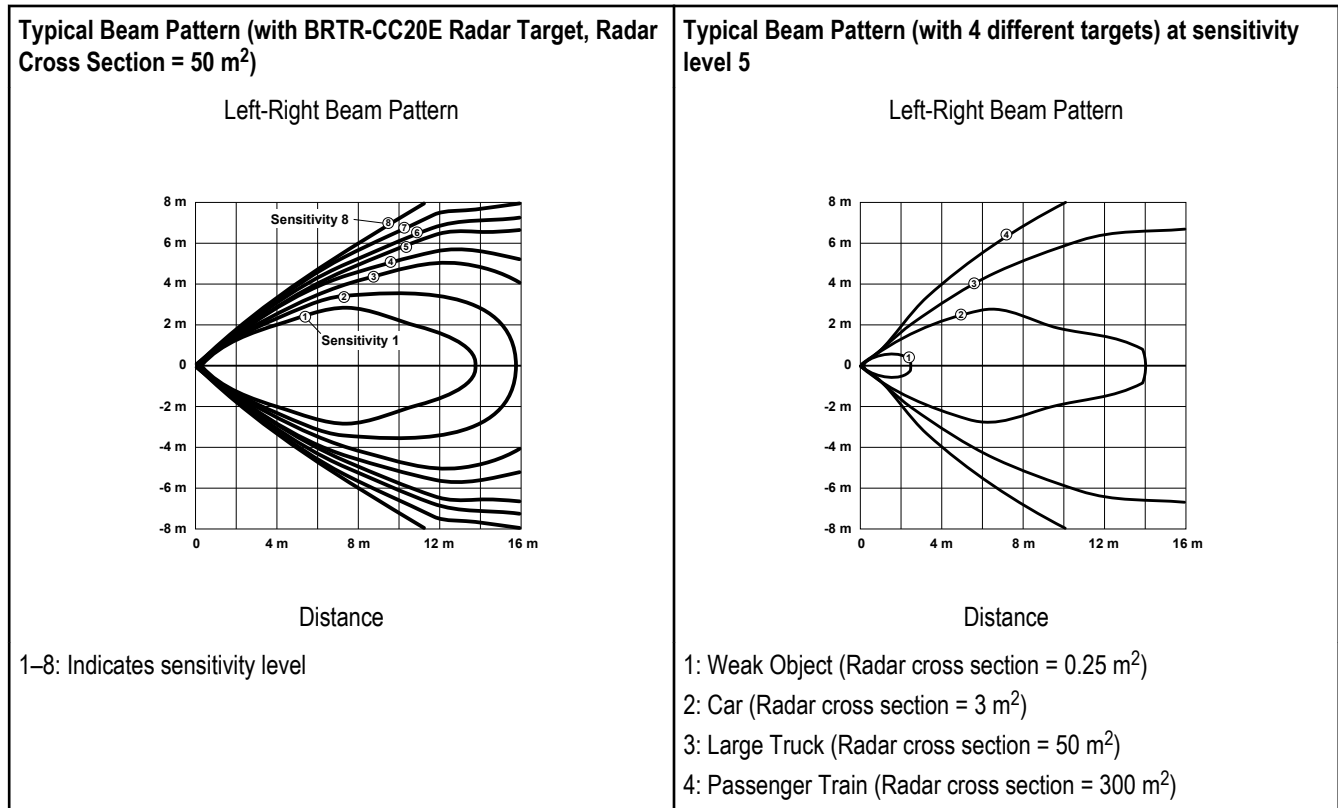

NOTE: The effective beam pattern depends on the sensitivity level and target properties.

The diagrams show the beam pattern with respect to the retroreflective target. The effective beam pattern for detection of foreground objects will be the size of the retroreflective target. For a flat retroreflective surface, the beam size is a 15 degree cone.

Dimensions

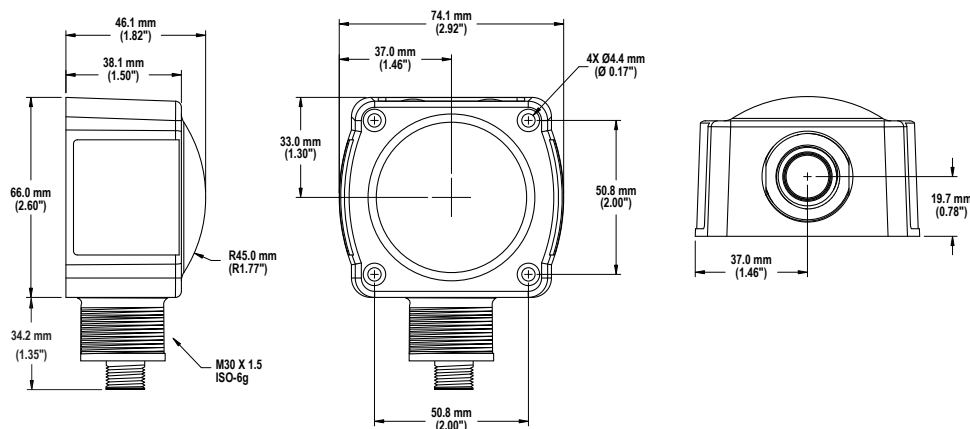

Hookup

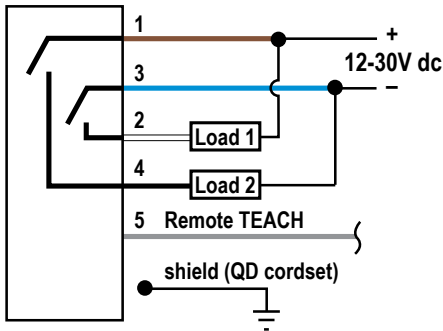

Wiring Key:

1 = Brown

2 = White

3 = Blue

4 = Black

5 = Gray (Float or connect to V+ for idle operation. Switch to ground for remote TEACH operation)



NOTE: Banner recommends that the shield wire (QD cordsets only) be connected to earth ground or dc common. Shielded cordsets are recommended for all QD models.

Quick Disconnect (QD) Cordsets

5-Pin Threaded M12/Euro-Style Cordsets with Shield				
Model	Length	Style	Dimensions	Pinout
MQDEC2-506	1.83 m (6 ft)	Straight		<p>1 = Brown 2 = White 3 = Blue 4 = Black 5 = Gray</p>
MQDEC2-515	4.57 m (15 ft)			
MQDEC2-530	9.14 m (30 ft)			
MQDEC2-550	15.2 m (50 ft)			
MQDEC2-506RA	1.83 m (6 ft)	Right-Angle		
MQDEC2-515RA	4.57 m (15 ft)			
MQDEC2-530RA	9.14 m (30 ft)			
MQDEC2-550RA	15.2 m (50 ft)			



NOTE: Pin 5 is not used.

Mounting Brackets

All measurements in mm

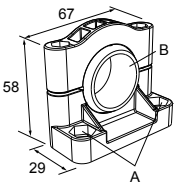
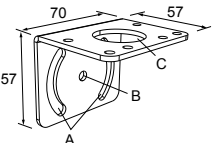
<p>SMB30SC</p> <ul style="list-style-type: none"> Swivel bracket with 30 mm mounting hole for sensor Black reinforced thermo-plastic polyester Stainless steel mounting and swivel locking hardware included  <p>Hole center spacing: A=∅ 50.8 Hole size: A=∅ 7.0, B=∅ 30.0</p>	<p>SMB30MM</p> <ul style="list-style-type: none"> 12-ga. stainless steel bracket with curved mounting slots for versatile orientation Clearance for M6 (1/4 in) hardware Mounting hole for 30 mm sensor  <p>Hole center spacing: A = 51, A to B = 25.4 Hole size: A = 42.6 x 7, B = ∅ 6.4, C = ∅ 30.1</p>
--	--

Retroreflective Target

<p>BRTR-CC20E</p> <ul style="list-style-type: none"> Large corner-cube reflector in protective plastic enclosure Provides 7x excess gain at 6 m 	
--	--

Weather Deflector

<p>QT50RCK</p> <ul style="list-style-type: none"> Required if the R-GAGE is exposed to rain or snow Prevents buildup of water or ice from interfering with sensor performance 	
--	---

Banner Engineering Corp Limited Warranty

Banner Engineering Corp. warrants its products to be free from defects in material and workmanship for one year following the date of shipment. Banner Engineering Corp. will repair or replace, free of charge, any product of its manufacture which, at the time it is returned to the factory, is found to have been defective during the warranty period. This warranty does not cover damage or liability for misuse, abuse, or the improper application or installation of the Banner product.

THIS LIMITED WARRANTY IS EXCLUSIVE AND IN LIEU OF ALL OTHER WARRANTIES WHETHER EXPRESS OR IMPLIED (INCLUDING, WITHOUT LIMITATION, ANY WARRANTY OF MERCHANTABILITY OR FITNESS FOR A PARTICULAR PURPOSE), AND WHETHER ARISING UNDER COURSE OF PERFORMANCE, COURSE OF DEALING OR TRADE USAGE.

This Warranty is exclusive and limited to repair or, at the discretion of Banner Engineering Corp., replacement. **IN NO EVENT SHALL BANNER ENGINEERING CORP. BE LIABLE TO BUYER OR ANY OTHER PERSON OR ENTITY FOR ANY EXTRA COSTS, EXPENSES, LOSSES, LOSS OF PROFITS, OR ANY INCIDENTAL, CONSEQUENTIAL OR SPECIAL DAMAGES RESULTING FROM ANY PRODUCT DEFECT OR FROM THE USE OR INABILITY TO USE THE PRODUCT, WHETHER ARISING IN CONTRACT OR WARRANTY, STATUTE, TORT, STRICT LIABILITY, NEGLIGENCE, OR OTHERWISE.**

Banner Engineering Corp. reserves the right to change, modify or improve the design of the product without assuming any obligations or liabilities relating to any product previously manufactured by Banner Engineering Corp.