

**Magnetic field sensor
magnet-inductive proximity sensor
BIM-M12E-AG4X**

- Threaded barrel, M12 x 1
- Chrome-plated brass
- Rated operating distance 90 mm with DMR31-15-5 magnet
- DC 2-wire, 10...65 VDC
- Polarized version
- NO contact
- Cable connection

Wiring diagram

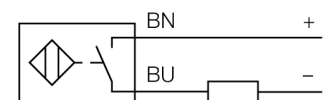

Functional principle

Magnetic inductive proximity sensors are actuated by magnetic fields and are thus capable of detecting permanent magnets through non-ferromagnetic materials (e.g. wood, plastic, non-ferrous metals, aluminium, stainless steel).

Thus it is possible to achieve large switching distances even with smaller housing styles. In combination with the actuation magnet DMR31-15-5 TURCK sensors feature a relatively high switching distance. Thus there are multiple detection possibilities, particularly if the mounting space is limited or other difficult sensing conditions prevail.

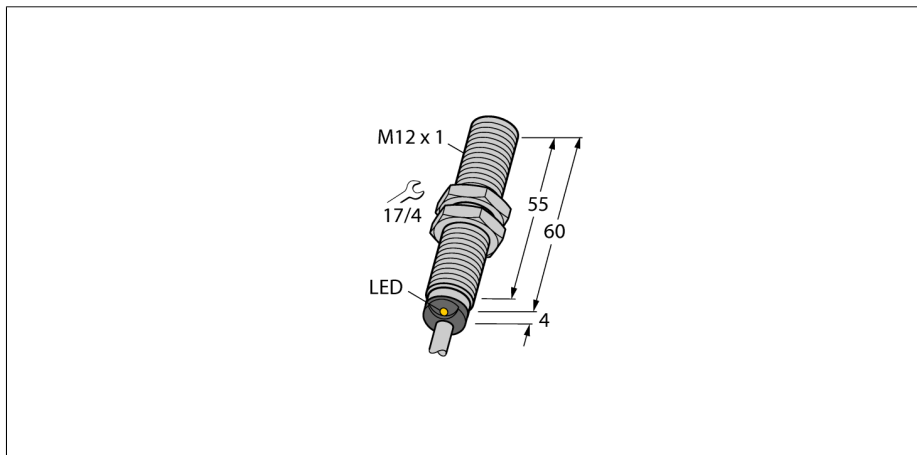
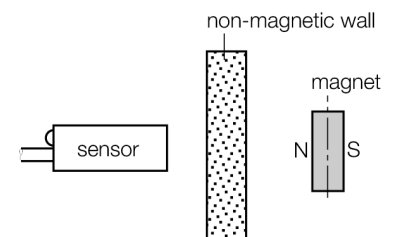

Type code	BIM-M12E-AG4X
Ident no.	4430200
Rated operating distance S_n	90 mm
Repeatability	in conjunction with magnet DMR31-15-5 ≤ 0.3 % of full scale
Temperaturdrift	15 %
Hysteresis	1...10 %
Ambient temperature	-25...+70 °C
Operating voltage	10...65VDC
DC rated operational current	≤ 200 mA
Residual current	≤ 0.8 mA
Rated insulation voltage	≤ 0.5 kV
Short-circuit protection	yes/ cyclic
Voltage drop at I _n	≤ 4.2 V
Wire breakage / Reverse polarity protection	no/ polarized
Output function	2-wire, NO contact, 2-wire
Smallest operating current I _o	≤ 3 mA
Switching frequency	0.3 kHz
Design	threaded barrel, M12 x 1
Dimensions	64 mm
Housing material	Metal, CuZn, chrome-plated
Material active face	Plastic, PA
End cap	Plastic, EPTR
Max. tightening torque housing nut	10 Nm
Connection	cable
Cable quality	5.2 mm, grey, LifYY-11Y, PUR, 2 m
Cable cross section	2 x 0.34 mm ²
Vibration resistance	55 Hz (1 mm)
Shock resistance	30 g (11 ms)
Protection class	IP67
MTTF	2283 years acc. to SN 29500 (Ed. 99) 40 °C
Switching state	● yellow
Diameter of the active area B	Ø 12 mm

**Magnetic field sensor
magnet-inductive proximity sensor
BIM-M12E-AG4X**

Accessories

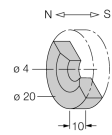
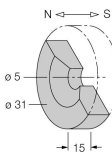
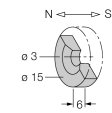
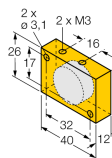
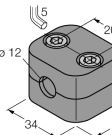
Type code	Ident no.	Description	Dimension drawing
DMR20-10-4	6900214	Actuation magnet; \varnothing 20 mm (\varnothing 4 mm), h: 10 mm; sensing range 59 mm on BIM-(E)M12 sensors resp. 50 mm on BIM-EG08 sensors; in combination with Q25L: Recommended distance between sensor and magnet: 3 ... 4 mm	
DMR31-15-5	6900215	Actuation magnet, \varnothing 31 mm (\varnothing 5 mm), h: 15 mm; sensing range 90 mm on BIM-(E)M12 sensors resp. 78 mm on BIM-EG08 sensors; in combination with Q25L: Recommended distance between sensor and magnet: 3 ... 5 mm	
DMR15-6-3	6900216	Actuation magnet, \varnothing 15 mm (\varnothing 3 mm), h: 6 mm; sensing range 36 mm on BIM-(E)M12 sensors resp. 32 mm on BIM-EG08 sensors; in combination with Q25L: Recommended distance between sensor and magnet: 3 ... 4 mm	
DM-Q12	6900367	Actuation magnet; cuboid-shaped plastic; sensing range 58 mm on BIM-(E)M12 sensors resp. 49 mm on BIM-EG08 sensors; in combination with Q25: Recommended distance between sensor and magnet: 3 ... 5 mm	
BSS-12	6901321	Mounting bracket for smooth and threaded barrel devices; material: Polypropylene	

**Magnetic field sensor
magnet-inductive proximity sensor
BIM-M12E-AG4X**

TURCK

Industrial
Automation

Accessories

Type code	Ident no.	Description	Dimension drawing
MW-12	6945003	Mounting bracket for threaded barrel devices; material: Stainless steel A2 1.4301 (AISI 304)	