

Flow sensor
Inline sensor with integrated processor
FCI-D10A4P-AP8X-H1141

- Flow sensor for liquid media
- Calorimetric principle
- Adjustment via potentiometer
- LED band
- Operating range 0.1...6 l/min
- 3-wire DC, 21...26 VDC
- NO contact, PNP output
- Plug-in device, M12 x 1

Wiring diagram

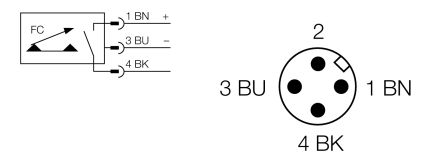

Functional principle

The function of the inline flow sensors is based on the thermo-dynamic principle. Heat is generated in a measuring tube and absorbed by the flowing medium. The transported heat loss is thus a measure of the flow speed. Thus TURCK's wear-free flow sensors reliably monitor the flow of gaseous and liquid media. A low pressure drop and fast response to flow rate variations are the outstanding features of these devices.

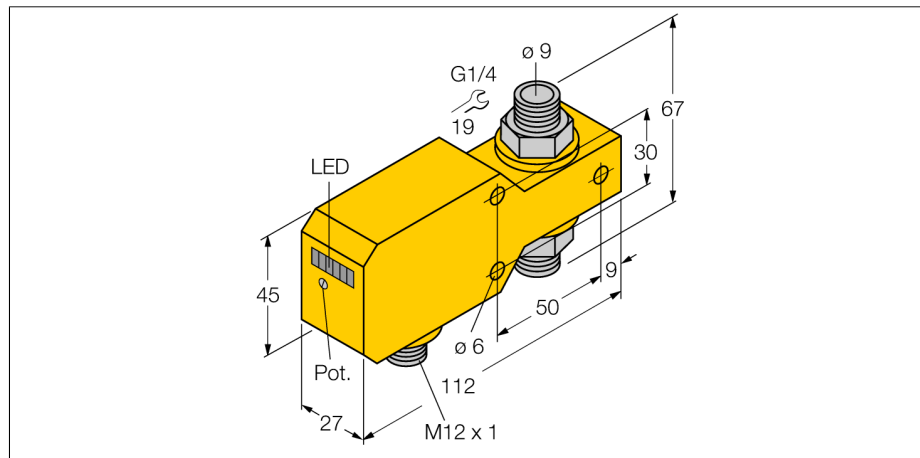

Type code	FCI-D10A4P-AP8X-H1141
Ident no.	6870642
Flow operating range	0,1...6 l/min.
Oil operating range	100...6000ml/min
Stand-by time	5...15 s
Switch-on time	0.5...1 s
Switch-off time	0.5...1 s
Temperature gradient	≤ 400 K/min
Medium temperature	-20...80 °C
Ambient temperature	0 ... 60 °C
Operating voltage	21...26VDC
No-load current I ₀	≤ 50 mA
Output function	PNP, NO contact
Rated operational current	0.2 A
Voltage drop at I ₀	≤ 1.5 V
Short-circuit protection	yes
Reverse polarity protection	yes
Housing material	Plastic, PBT
Sensor material	stainless steel, AISI 316Ti
Max. tightening torque housing nut	100 Nm
Connection	male, M12 x 1
Pressure resistance	20 bar
Mechanical connection	G 1/4"
Switching state	LED chain green / yellow / red
Indication: Drop below setpoint	LED red
Indication: Setpoint reached	LED yellow
Indication: Setpoint exceeded	4 x LEDs green