

Flow sensor
Immersion sensor with integrated processor
FCS-G1/2DY-AP8X-H1141

- Flow sensor for liquid media
- Calorimetric principle
- Adjustment via potentiometer
- LED band
- Sensor made of PVDF
- 3-wire DC, 21...26 VDC
- NO contact, PNP output
- Plug-in device, M12 x 1

Wiring diagram

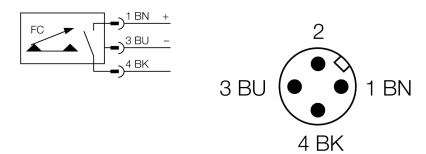

Functional principle

Our insertion - flow sensors operate on the principle of thermodynamics. The measuring probe is heated by several °C as against the flow medium. When fluid moves along the probe, the heat generated in the probe is dissipated. The resulting temperature is measured and compared to the medium temperature. The flow status of every medium can be derived from the evaluated temperature difference. Thus TURCK's wear-free flow sensors reliably monitor the flow of gaseous and liquid media.

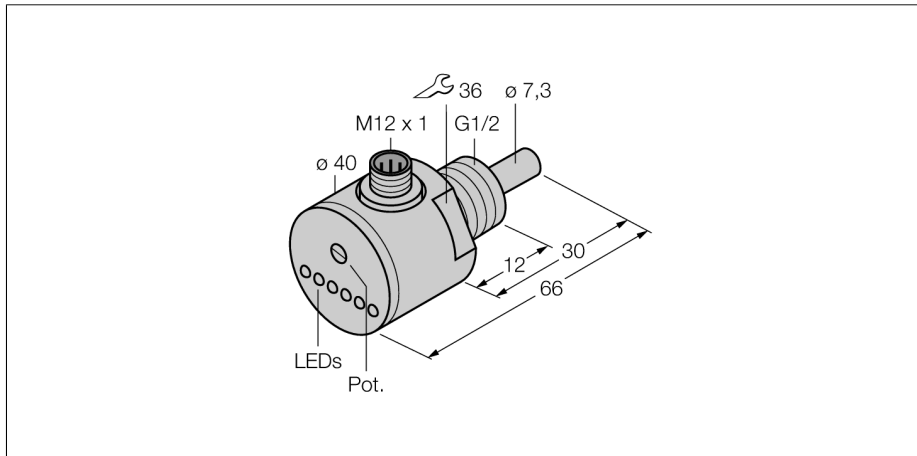

Type code	FCS-G1/2DY-AP8X-H1141
Ident no.	6870003
Operating range water	
Oil operating range	1...70cm/s
Stand-by time	2...100 cm/s
Switch-on time	typ. 60 s (40...100 s)
Switch-off time	typ. 30 s (5...50 s)
Temperature jump, response time	typ. 30 s (5...50 s)
Temperature gradient	typ. 100 s (50...100 s)
Medium temperature	≤ 30 K/min
	-10...80 °C
Operating voltage	
No-load current I ₀	21...26VDC
Output function	≤ 70 mA
Rated operational current	PNP, NO contact
Voltage drop at I ₀	0.4 A
Short-circuit protection	≤ 1.5 V
Reverse polarity protection	yes
	yes
Housing material	
Sensor material	Plastic, PVDF
Max. tightening torque housing nut	plastic, PVDF
Connection	5 Nm
Pressure resistance	male, M12 x 1
Mechanical connection	5 bar
	G 1/2"
Switching state	
Indication: Drop below setpoint	LED chain green / yellow / red
Indication: Setpoint reached	LED red
Indication: Setpoint exceeded	LED yellow
	4 x LEDs green