

2 port junction systems

Y junction male 12 x 1 connector - 2 female M8 x 1 connectors

FSM4-2SKP3-1,5/1,5/XOR

- **robust and pre-assembled Y junction**
- **Degree of protection IP67**
- **also available with different cable lengths and of different materials**
- **irradiated PVC**
- **high short-term temperature resistance (+250 °C)**

Wiring diagram

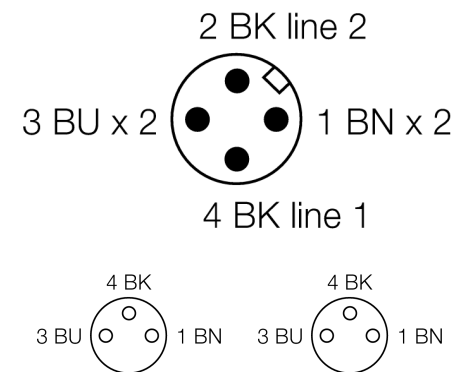

Cable quality XOR

Due to its irradiated cable jacket, this pure PVC cable features increased thermostability at higher temperatures, improved mechanical rigidity, resistance to chemicals and abrasion compared to a standard PVC cable.

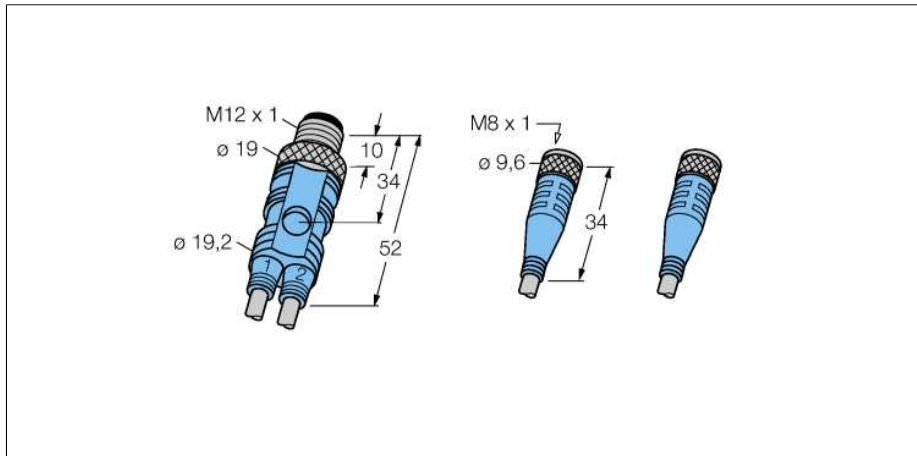
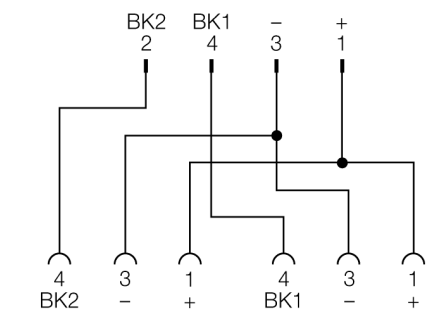

Type code	FSM4-2SKP3-1,5/1,5/XOR
Ident no.	8008063
Junction box	Y-piece, with cable, screwable
Number of pins	4/3
Grip	plastic, TPU
Connector B side	male connector, 1x, M12 x 1, straight
Number of pins	3
Grip	plastic, TPU, blue
Contact carriers	plastic, TPU, black
Contacts	metal, CuZn, gold-plated
Coupling nut/screw	metal, CuZn, nickel-plated
Protection class	IP67, (screwed together)
Mechanical lifespan	> 100 mating cycles
Pollution degree	3
Connector	female connector, 2x, M8x1, straight
Polarity	3-pole
Grip	plastic, TPU, blue
Contact carriers	plastic, TPU, black
Contacts	metal, CuZn, gold-plated
Coupling nut/screw	metal, CuZn, nickel-plated
Seal	plastic, FKM/FPM
Protection class	IP67, only in class
Mechanical lifespan	> 100 contact durability
Pollution degree	3
Cable	XOR, LifXX, 4.4
Cable length	1.5/ 1.5m
Cable sheath	PVC, OG
Core insulation	PVC
Core colors	BN, BU, BK
Core cross-section	4x0.25mm ²
Litz wire arrangement	32x0.1 mm
Bending radius (mobile)	min. 10 x Ø cable
Rated voltage [Umax]	60 V
Ampacity	4 A
Forward resistance	≤ 5 mΩ
Insulation resistance	≥ 10 ⁹ Ω
Ambient temperature junction	-30 ... +90 °C
Cable ambient temperature	-40... +80 °C +250 °C short-term