

Industrial sensor cable
PVC-Kabelmantel
MKAU14.003-10/S1118

TURCK

Industrial
Automation

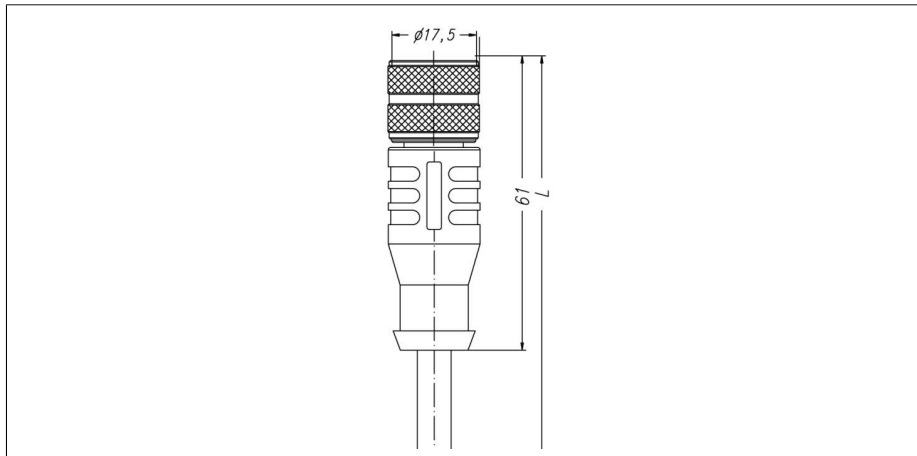

- Field-wireable and overmoulded connection cable
- Other cable lengths available

Wiring diagram

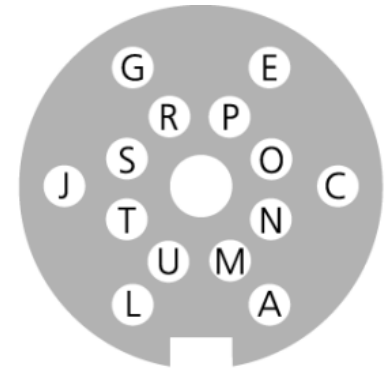

A: n.c.	N: YE
C: GN	O: GY
E: PK	P: BK
G: RD	R: WH
J: VT	S: n.c.
L: n.c.	T: n.c.
M: BN	U: BU

Type code	MKAU14.003-10/S1118
Ident no.	8029872
Connector A side	female connector, M16 x 0.75, axial
Number of pins	14
Contacts	metal, CuZn, gold-plated
Contact carriers	plastic, TPU, black
Grip	plastic, TPU, blue
Coupling nut/screw	metal, CuZn, nickel-plated
Seal	plastic, NBR
Mechanical lifespan	> 100 mating cycles
Pollution degree	3
Cable	S1118, LifYY-0
Cable diameter	8 mm
Cable length	10m
Cable sheath	PVC, BK
Core insulation	PVC
Core colors	BK, PK, YE, WH, VT, RD, GY, GN BU, BN
Core cross-section	8x0.25mm ² 2x0.5mm ²
Bending radius (mobile)	min. 10 x Ø cable
Rated voltage [U_{max}]	32 V
Insulation resistance	≥ 10 ⁸ Ω
Ampacity	6A contacts M,U 2A all other contacts
Ambient temperature Connector	-30... +90°C
Cable ambient temperature	-40... +80°C

Cable quality S1118

Pure PVC cable, resistant to average mechanical strain. For use in packaging machinery as well as assembly and production lines. Good resistance to acids and alkaline solutions and thus suited for the Food& Beverage industry. Limited resistance to abrasion, conditional resistance to oils and chemicals.