

# GPTR1494

## PHASE CONTROLLED SCR

High reliability operation  
Electroplating applications  
Resistance welding applications

**BLOCKING VOLTAGE UP TO 800 V**  
**AVERAGE CURRENT 4940 A**  
**SURGE CURRENT 50 kA**

### BLOCKING CHARACTERISTICS

Characteristic	Conditions	Value
V <sub>RRM</sub>	Repetitive peak reverse voltage	800 V
V <sub>RSM</sub>	Non-repetitive peak reverse voltage	900 V
V <sub>DRM</sub>	Repetitive peak off-state voltage	800 V
I <sub>DRM</sub>	Repetitive peak off-state current, max.	V <sub>DRM</sub> , single phase, half wave, T <sub>j</sub> = T <sub>jmax</sub>
I <sub>RRM</sub>	Repetitive peak reverse current, max.	V <sub>RRM</sub> , single phase, half wave, T <sub>j</sub> = T <sub>jmax</sub>

### ON-STATE CHARACTERISTICS

I <sub>T(AV)</sub>	Average on-state current	Sine wave, 180° conduction, T <sub>h</sub> = 55 °C	4940 A
I <sub>T(RMS)</sub>	R.M.S. on-state current	Sine wave, 180° conduction, T <sub>h</sub> = 55 °C	7760 A
I <sub>TSM</sub>	Surge on-state current	Non rep. half sine wave, 50 Hz, V <sub>R</sub> = 0 V, T <sub>j</sub> = T <sub>jmax</sub>	50 kA
I <sup>2</sup> t	I <sup>2</sup> t for fusing coordination		12500 kA <sup>2</sup> s
V <sub>T(TO)</sub>	Threshold voltage	T <sub>j</sub> = T <sub>jmax</sub>	0,87 V
r <sub>T</sub>	On-state slope resistance	T <sub>j</sub> = T <sub>jmax</sub>	0,06 mΩ
V <sub>TM</sub>	Peak on-state voltage, max	On-state current I <sub>T</sub> = 5000 A, T <sub>j</sub> = T <sub>jmax</sub>	1,17 V
I <sub>H</sub>	Holding current, max	T <sub>j</sub> = 25 °C	170 mA
I <sub>L</sub>	Latching current, typ	T <sub>j</sub> = 25 °C	1500 mA

### TRIGGERING CHARACTERISTICS

V <sub>GT</sub>	Gate trigger voltage	T <sub>j</sub> = 25 °C, V <sub>D</sub> = 12 V	3 V
I <sub>GT</sub>	Gate trigger current	T <sub>j</sub> = 25 °C, V <sub>D</sub> = 12 V	250 mA
V <sub>GD</sub>	Non-trigger voltage	V <sub>D</sub> = 67% V <sub>RRM</sub> , T <sub>j</sub> = T <sub>jmax</sub>	0,2 V
P <sub>GM</sub>	Peak gate power dissipation	Pulse width 0.5 ms	100 W
P <sub>G(AV)</sub>	Average gate power dissipation		5 W
I <sub>FGM</sub>	Peak gate current		10 A
V <sub>FGM</sub>	Peak gate voltage (forward)		12 V
V <sub>RGM</sub>	Peak gate voltage (reverse)		10 V

### SWITCHING CHARACTERISTICS

di/dt	Critical rate of rise of on-state current	T <sub>j</sub> = T <sub>jmax</sub>	200 A/μs
dV/dt	Critical rate of rise of off-state voltage	T <sub>j</sub> = T <sub>jmax</sub>	1000 V/μs
t <sub>q</sub>	Turn-off time, typ	T <sub>j</sub> = T <sub>jmax</sub> , I <sub>T</sub> = 4000 A, di/dt = -12.5 A/μs V <sub>R</sub> = 100 V, V <sub>D</sub> = 67% V <sub>DRM</sub> , dV/dt = 20 V/μs	300 μs

### THERMAL AND MECHANICAL CHARACTERISTICS

R <sub>th(j-c)</sub>	Thermal resistance (junction to case)	Double side cooled	0,010 °C/W
R <sub>th(c-h)</sub>	Thermal resistance (case to heatsink)	Double side cooled	0,002 °C/W
T <sub>jmax</sub>	Max operating junction temperature		150 °C
T <sub>stg</sub>	Storage temperature		-40 / 150 °C
F	Clamping force ± 10%		50 kN
	Mass		950 g

Current rating - sine wave

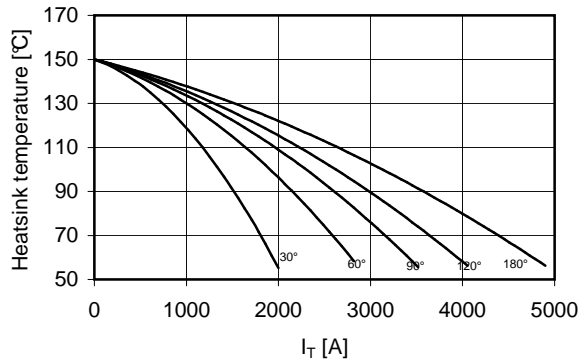

Power loss - sine wave

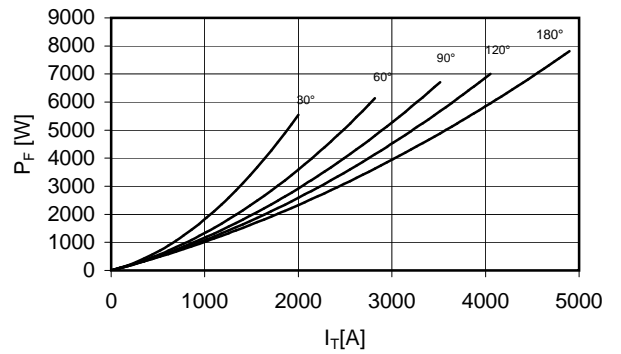

Maximum surge current d.s. cooled

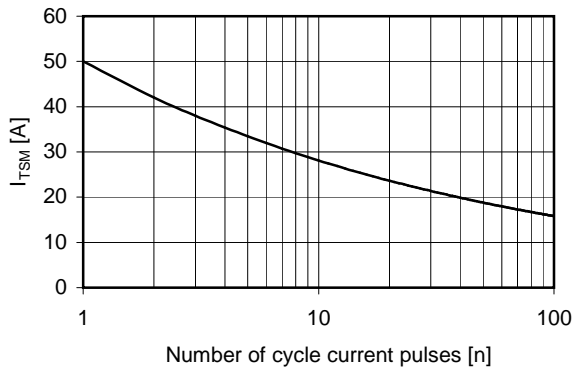

On-state voltage drop

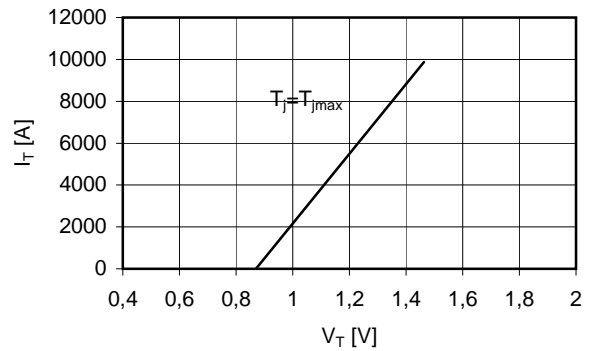

Thermal impedance (j-c)

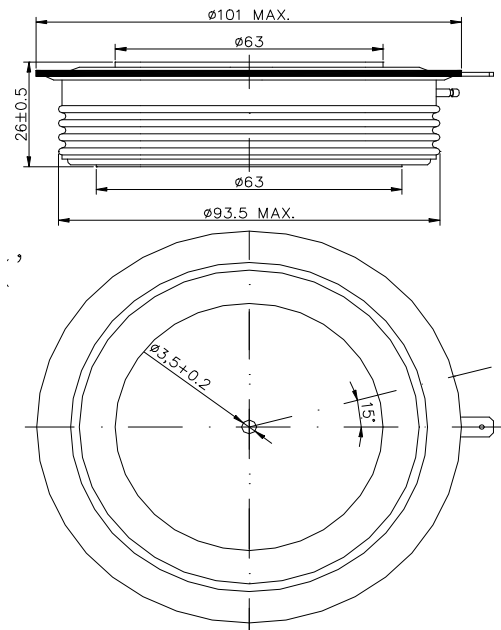
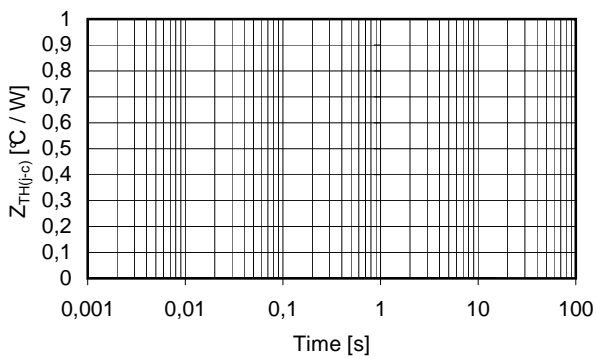

In the interest of product improvement Green Power Solutions reserves the right to change any specification given in this data sheet without notice.