

**MAIN FEATURES**

Symbol	Value	Unit
$I_{T(RMS)}$	1	A
$V_{(DRM)}/V_{RRM}$	400 to 600	V
$I_{GT(Q1)}$	3 to 25	mA

**GENERAL DESCRIPTION**

The MAC97A6 series is suitable for general purpose AC switching applications. They can be found in applications such as home appliances (electro-valve, pump, door lock, small lamp control), fan speed controllers,

Different gate current sensitivities are available, allowing optimized performances when controlled directly from micro-controllers.

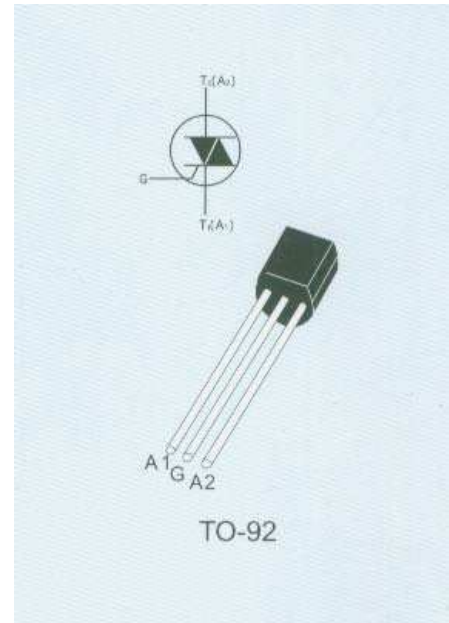
**ABSOLUTE MAXIMUM RATINGS**

Symbol	Parameter		Value	Unit
$I_{T(RMS)}$	RMS on-state current (full sine wave)	TO-92 Tc=50°C	1	A
$I_{TSM}$	Non repetitive surge peak on-state current (full cycle, Tj initial=25°C)	F=50Hz t=20ms	8	A
		F=60Hz t=16.7ms	8.5	
$I^2T$	$I^2T$ Value for fusing	tp=10ms	0.35	A <sup>2</sup> s
dl/dt	Critical rate of rise of on-state current $I_G=2 \times I_{GT}$ , tr≤100ns	F=120Hz Tj=125°C	20	A/μs
$I_{GM}$	Peak gate current	tp=20μs Tj=125°C	1	A
$P_{G(AV)}$	Average gate power dissipation	Tj=125°C	0.1	W
$T_{stg}$	Storage junction temperature range		-40 to+150	°C
$T_j$	Operating junction temperature range		-40 to+125	

**■ STATIC CHARACTERISTICS**

T<sub>j</sub>=25°C unless otherwise stated

Symbol	Test Conditions	Quadrant		Value		Unit
				Typ	Max	
I <sub>GT</sub> <sup>(1)</sup>	V <sub>D</sub> =12V R <sub>L</sub> =30Ω	I-II-III		5	10	mA
		IV		7	10	
V <sub>GT</sub>		ALL	MAX.	1.5		V
V <sub>GD</sub>	V <sub>D</sub> =V <sub>DRM</sub> R <sub>L</sub> =3.3KΩ T <sub>j</sub> =125°C	ALL	MIN.	0.2		V
I <sub>H</sub> <sup>(2)</sup>	I <sub>T</sub> =50mA		MAX.	10	25	mA
I <sub>L</sub>	I <sub>G</sub> =1.2I <sub>GT</sub>	I-III-IV	MAX.	10	25	mA
		II		20	50	
V <sub>TM</sub> <sup>(2)</sup>	I <sub>TM</sub> =1.4A tp=380μs	T <sub>j</sub> =25°C	MAX.	1.6		V
V <sub>IO</sub> <sup>(2)</sup>	Threshold voltage	T <sub>j</sub> =125°C	MAX.	0.95		V
R <sub>d</sub> <sup>(2)</sup>	Dynamic resistance	T <sub>j</sub> =125°C	MAX.	400		mΩ
I <sub>DRM</sub> I <sub>RRM</sub>	V <sub>DRM</sub> =V <sub>RRM</sub>	T <sub>j</sub> =25°C	MAX.	50		μA
		T <sub>j</sub> =125°C		0.5		mA

**■ DYNAMIC CHARACTERISTICS**

Symbol	Test Condition		Typ	Max	Unit
dV/dt <sup>(2)</sup>	V <sub>D</sub> =67% V <sub>DRM</sub> gate open T <sub>j</sub> =110°C	MIN	50	100	V/μs
(dV/dt) <sub>c</sub> <sup>(2)</sup>	(dI/dt) <sub>c</sub> =0.44A/ms T <sub>j</sub> =110°C	MIN	2	5	V/μs

**Note1:** minimum I<sub>GT</sub> is guaranteed at 5% of I<sub>GT</sub> max.

**Note2:** for both polarities of A2 referenced to A1.

**■ THERMAL RESISTANCES**

Symbol	Parameter		Value	Unit
R <sub>th(j-l)</sub>	Junction to lead (AC)	TO-92	60	°C/W
R <sub>th(j-a)</sub>	Junction to ambient	TO-92	150	°C/W

**PERFORMANCE CURVES**

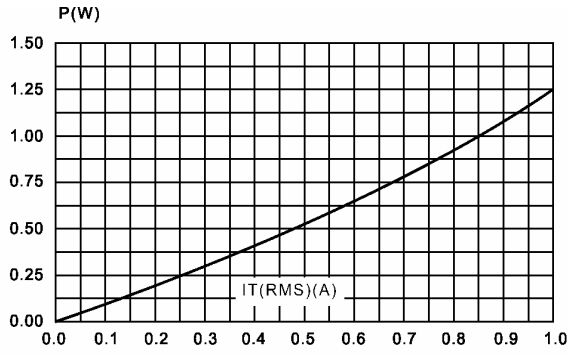

Fig.1. Maximum power dissipation versus RMS on-state current (full cycle)

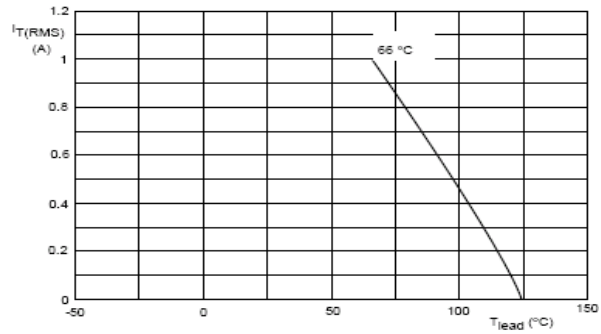

Fig.4. RMS on-state current versus ambient temperature (full cycle)

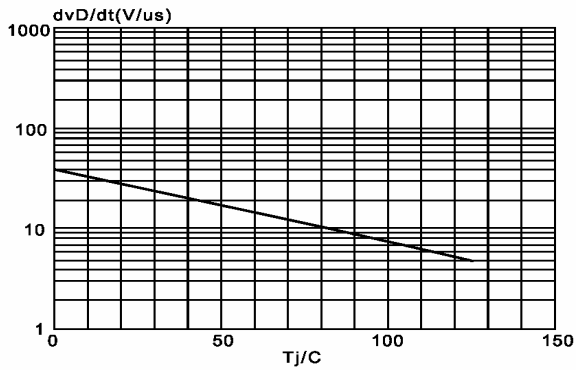

Fig.2. Typical, critical rate of rise off-state voltage,  $dv_D/dt$  versus junction temperature  $T_j$

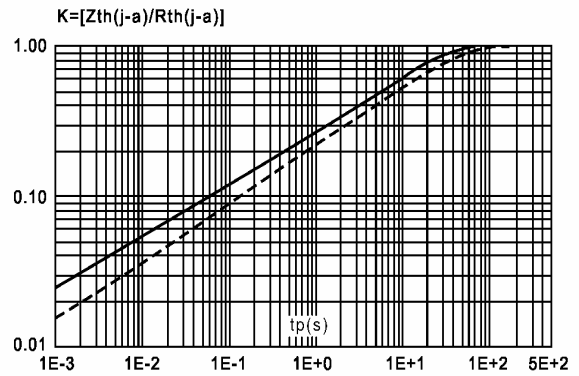

Fig.5. Relative variation of thermal impedance junction to ambient versus pulse duration

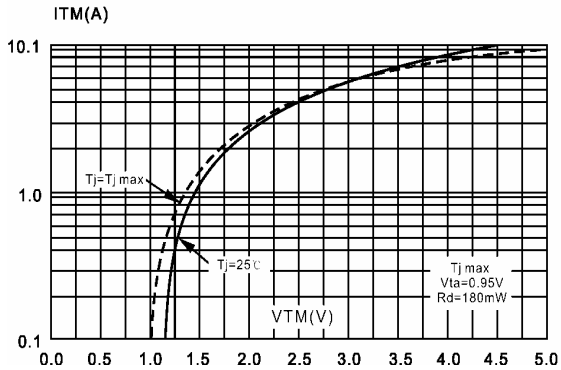

Fig.3. On-state characteristics (maximum values),

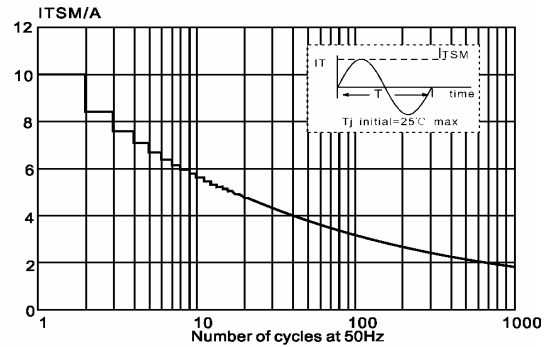

Fig.6. Maximum permissible non-repetitive peak on-state current  $I_{TSM}$  versus number of cycles, for sinusoidal currents,  $f=50\text{Hz}$

**PERFORMANCE CURVES**

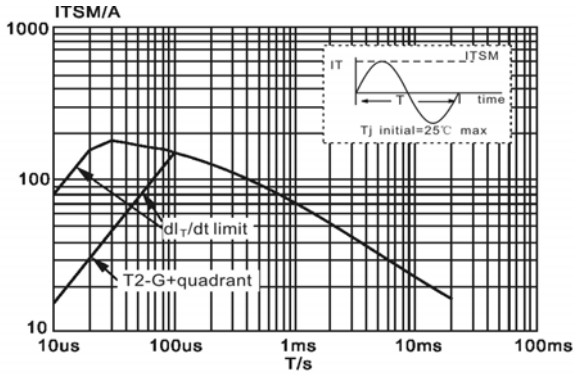

Fig. 7. Maximum permissible non-repetitive peak on-state current  $I_{TSM}$  versus pulse width  $t_p$ , for sinusoidal currents,  $t_p \leq 20ms$

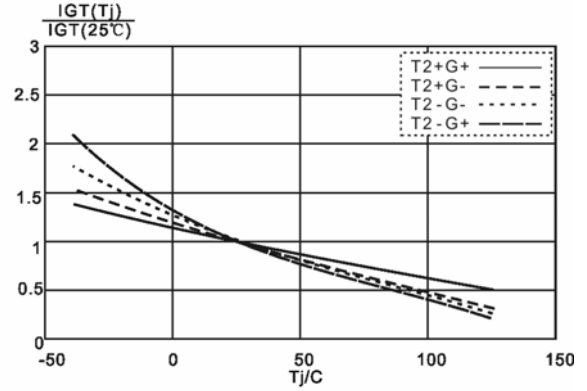

Fig. 10. Normalized gate trigger current  $I_{GT}(T_j)/I_{GT}(25^\circ C)$ , versus junction temperature  $T_j$

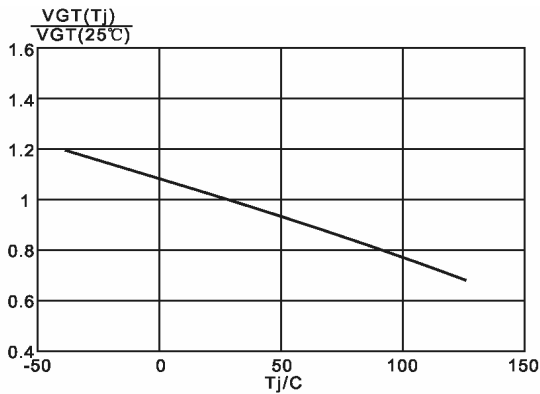

Fig. 8. Normalized gate trigger voltage  $V_{GT}(T_j)/V_{GT}(25^\circ C)$ , versus junction temperature  $T_j$

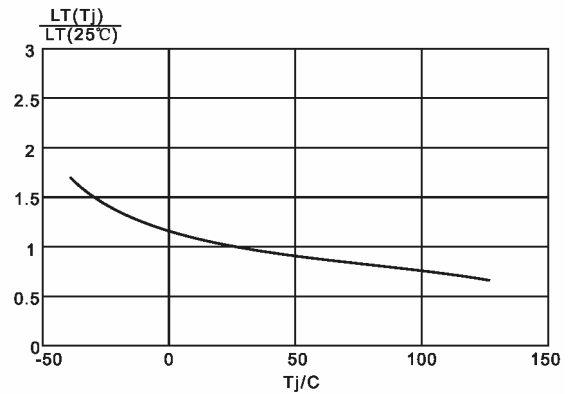

Fig. 11. Normalized latching current  $I_L(T_j)/I_L(25^\circ C)$ , versus junction temperature  $T_j$

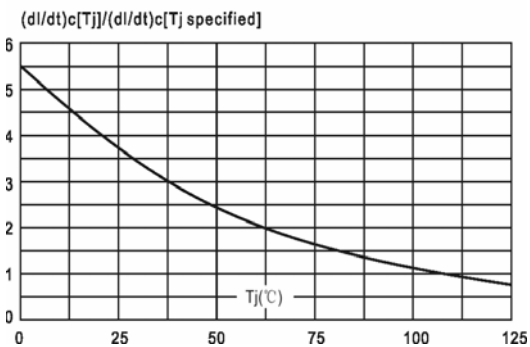

Fig. 9. Relative variation of critical rate of decrease of main current versus junction temperature  $T_j$

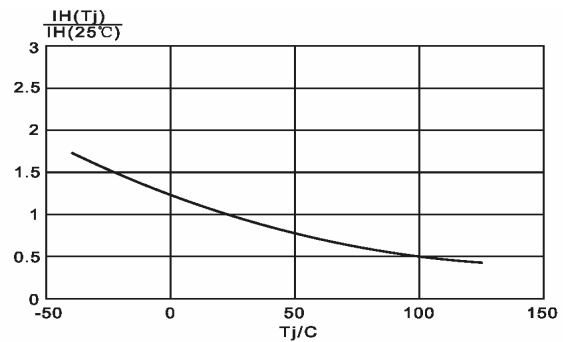
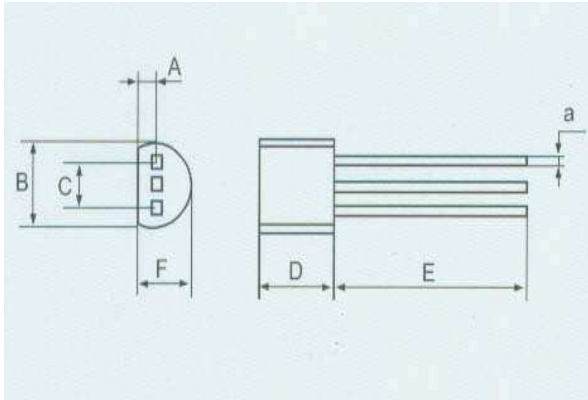

Fig. 12. Normalized holding current  $I_H(T_j)/I_H(25^\circ C)$ , versus junction temperature  $T_j$

**PACKAGE MECHANICAL DATA**

TO-92(Plastic)



REF.	DIMENSIONS					
	Millimeters			Inches		
	Min.	Typ.	Max.	Min.	Typ.	Max.
A		1.35			0.053	
B			4.70			0.185
C		2.54			0.100	
D	4.40			0.173		
E	12.70			0.500		
F			3.70			0.146
a			0.45			0.017