

MAIN FEATURES

Symbol	Value	Unit
$I_{T(RMS)}$	1	A
$V_{(DRM)}/V_{RRM}$	600 to 800	V
$I_{GT(Q1)}$	3 to 25	mA

GENERAL DESCRIPTION

The BTN01 series is suitable for general purpose AC switching applications. They can be found in applications such as home appliances (electro-valve, pump, door lock, small lamp control), fan speed controllers,

Different gate current sensitivities are available, allowing optimized performances when controlled directly from micro-controllers.

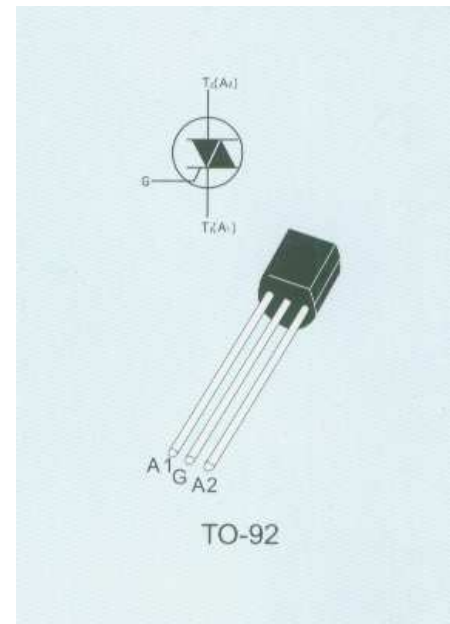
ABSOLUTE MAXIMUM RATINGS

Symbol	Parameter			Value	Unit
$I_{T(RMS)}$	RMS on-state current (full sine wave)	TO-92	$T_c=50^\circ\text{C}$	1	A
I_{TSM}	Non repetitive surge peak on-state current (full cycle, T_j initial= 25°C)	F=50Hz	t=20ms	8	A
		F=60Hz	t=16.7ms	8.5	
I^2T	I^2T Value for fusing	tp=10ms		0.35	A^2s
dI/dt	Critical rate of rise of on-state current $I_G=2 \times I_{GT}$, tr \leq 100ns	F=120Hz	$T_j=125^\circ\text{C}$	20	A/ μs
I_{GM}	Peak gate current	tp=20 μs	$T_j=125^\circ\text{C}$	1	A
$P_{G(AV)}$	Average gate power dissipation	$T_j=125^\circ\text{C}$		0.1	W
T_{sig}	Storage junction temperature range			-40 to+150	$^\circ\text{C}$
T_j	Operating junction temperature range			-40 to+125	

■ STATIC CHARACTERISTICS

 T_j=25°C unless otherwise stated

Symbol	Test Conditions	Quadrant		Value			Unit
				D	E	C	
I _{GT} ⁽¹⁾	V _D =12V R _L =30Ω	I-II-III	MAX.	5	10	25	mA
		IV		7	10	25	
V _{GT}		ALL	MAX.	1.5			V
V _{GD}	V _D =V _{DRM} R _L =3.3KΩ T _j =125°C	ALL	MIN.	0.2			V
I _H ⁽²⁾	I _T =50mA		MAX.	10	10	25	mA
I _L	I _G =1.2I _{GT}	I-III-IV	MAX.	10	15	25	mA
		II		20	25	50	
V _{TM} ⁽²⁾	I _{TM} =1.4A tp=380μs	T _j =25°C	MAX.	1.6			V
V _{to} ⁽²⁾	Threshold voltage	T _j =125°C	MAX.	0.95			V
R _d ⁽²⁾	Dynamic resistance	T _j =125°C	MAX.	400			mΩ
I _{DRM} I _{RDM}	V _{DRM} =V _{RRM}	T _j =25°C	MAX.	50			μA
		T _j =125°C		0.5			mA

■ DYNAMIC CHARACTERISTICS

Symbol	Test Condition		D	E	C	Unit
dV/dt ⁽²⁾	V _D =67% V _{DRM} gate open T _j =110°C	MIN	20	50	100	V/μs
(dV/dt) _C ⁽²⁾	(dI/dt) _C =0.44A/ms T _j =110°C	MIN	1	2	5	V/μs

Note1: minimum I_{GT} is guaranteed at 5% of I_{GT} max.

Note2: for both polarities of A2 referenced to A1.

■ THERMAL RESISTANCES

Symbol	Parameter		Value	Unit
R _{th(j-l)}	Junction to lead (AC)	TO-92	60	°C/W
R _{th(j-a)}	Junction to ambient	TO-92	150	°C/W

PERFORMANCE CURVES

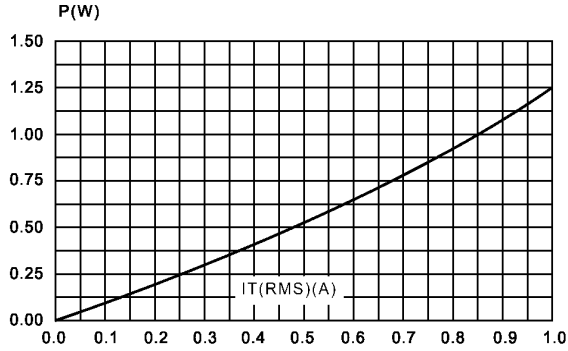

Fig. 1. Maximum power dissipation versus RMS on-state current (full cycle)

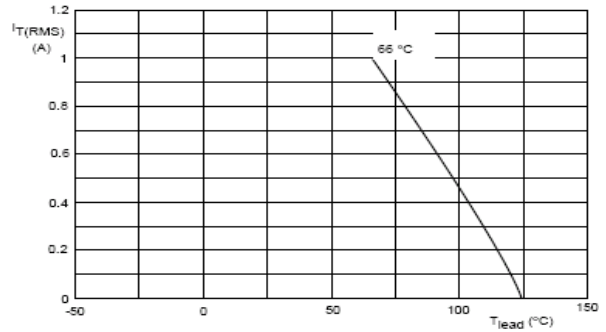

Fig. 4. RMS on-state current versus ambient temperature (full cycle)

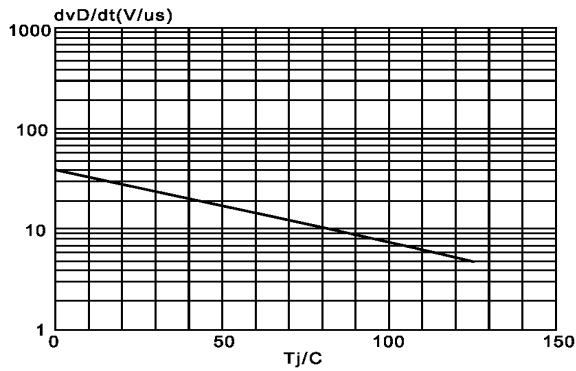

Fig. 2. Typical, critical rate of rise off-state voltage, dv_D/dt versus junction temperature T_j

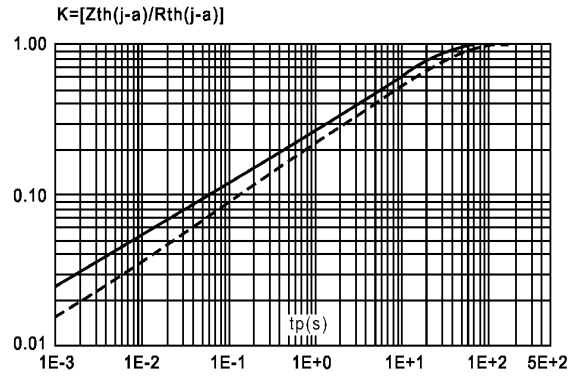

Fig. 5. Relative variation of thermal impedance junction to ambient versus pulse duration

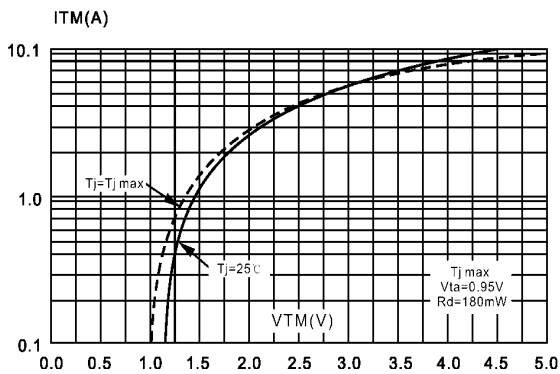

Fig. 3. On-state characteristics (maximum values),

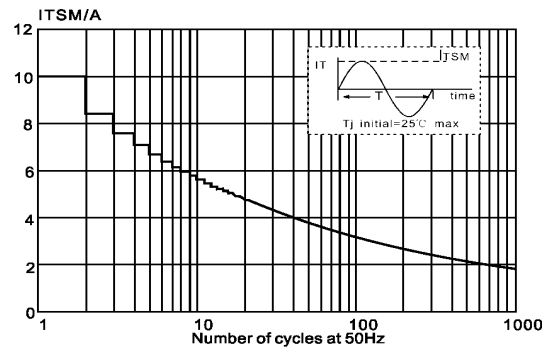

Fig. 6. Maximum permissible non-repetitive peak on-state current I_{TSM} versus number of cycles, for sinusoidal currents, $f=50\text{Hz}$

PERFORMANCE CURVES

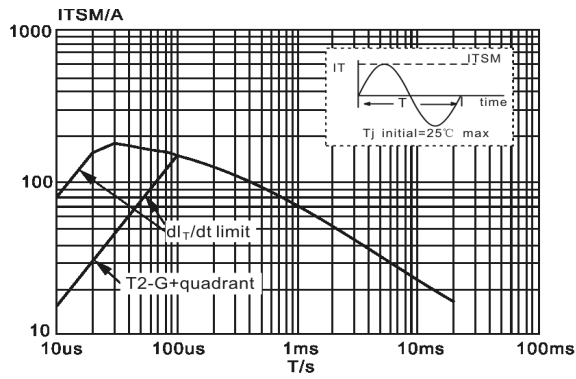

Fig. 7. Maximum permissible non-repetitive peak on-state current I_{TSM} versus pulse width t_p , for sinusoidal currents, $t_p \leq 20ms$

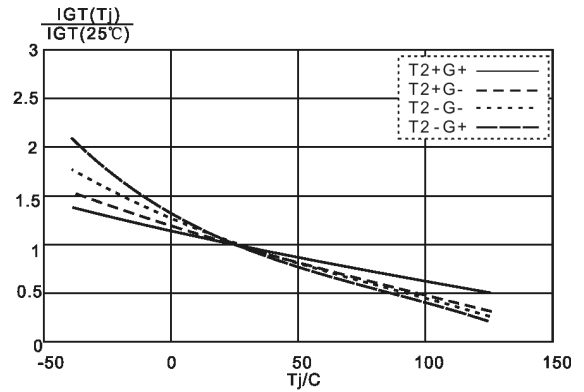

Fig. 10. Normalized gate trigger current $I_{GT}(T_j)/I_{GT}(25^\circ C)$, versus junction temperature T_j

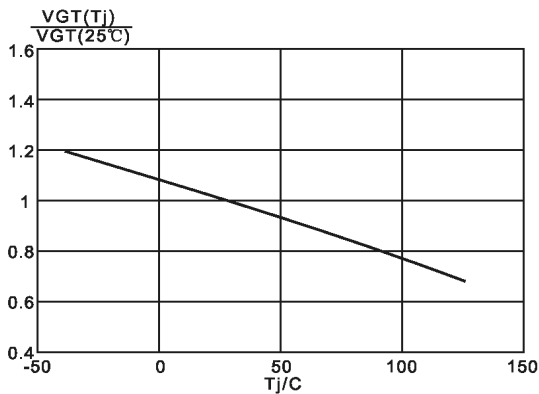

Fig. 8. Normalized gate trigger voltage $V_{GT}(T_j)/V_{GT}(25^\circ C)$, versus junction temperature T_j

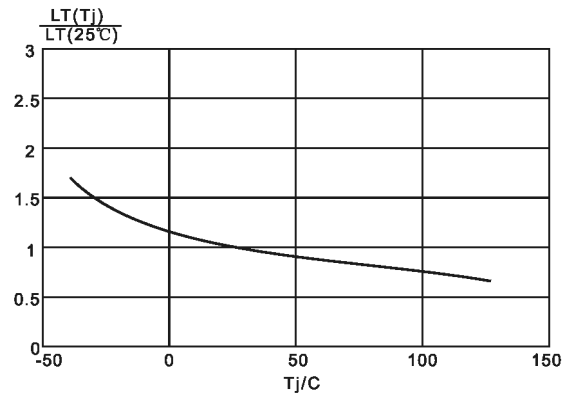

Fig. 11. Normalized latching current $I_L(T_j)/I_L(25^\circ C)$, versus junction temperature T_j

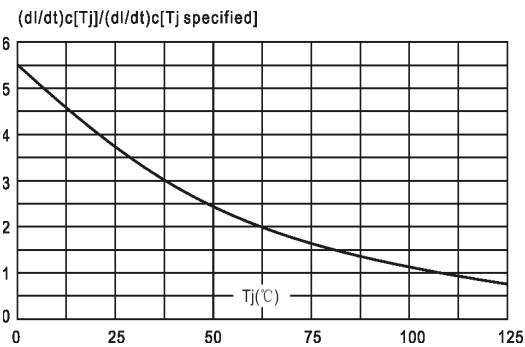

Fig. 9. Relative variation of critical rate of decrease of main current versus junction temperature T_j

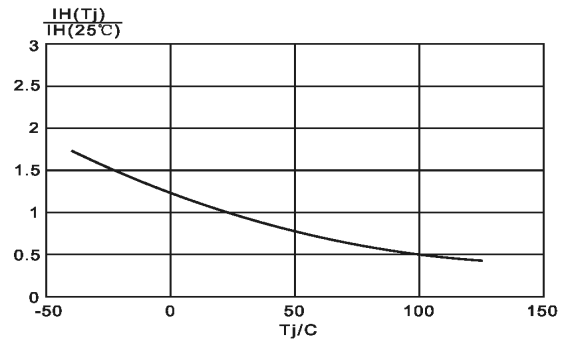
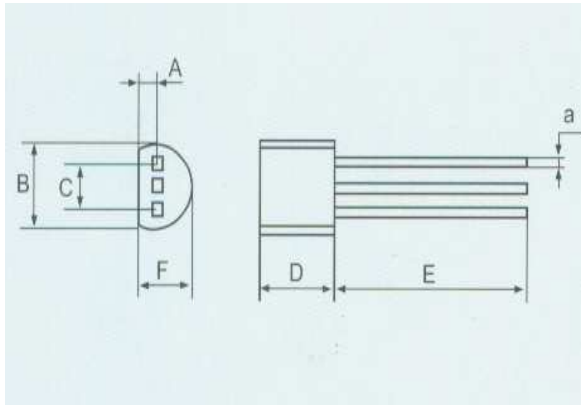

Fig. 12. Normalized holding current $I_H(T_j)/I_H(25^\circ C)$, versus junction temperature T_j

PACKAGE MECHANICAL DATA

TO-92(Plastic)



REF.	DIMENSIONS					
	Millimeters			Inches		
	Min.	Typ.	Max.	Min.	Typ.	Max.
A		1.35			0.053	
B			4.70			0.185
C		2.54			0.100	
D	4.40			0.173		
E	12.70			0.500		
F			3.70			0.146
a			0.45			0.017