



Micro Commercial Components



Micro Commercial Components
20736 Marilla Street Chatsworth
CA 91311
Phone: (818) 701-4933
Fax: (818) 701-4939

TL431AU

Features

- Lead Free Finish/RoHS Compliant ("P" Suffix designates RoHS Compliant. See ordering information)
- Epoxy meets UL 94 V-0 flammability rating
- Moisture Sensitivity Level 1
- Programmable Output Voltage 36V
- Sink Current Capability of 0.1mA to 100 mA
- Temperature Compensated for operation over full rated operating temperature range
- Low output noise voltage and Fast turn on response
- The Reference Input Voltage tolerance is 1%
- Marking Code: 431
- Halogen free available upon request by adding suffix "-HF"

Programmable Precision Regulator

Maximum Ratings

Parameter	Symbol	Value	Unit
Cathode Voltage	V_{KA}	37	V
Cathode Current Range	I_K	-100~150	mA
Reference Input Current Range	I_{REF}	0.05~10	mA
Power Dissipation at 25°C	P_D	0.2	W
Thermal Resistance Junction to Ambient	$R_{\theta JA}$	300	°C/W
Junction Temperature	T_J	0~150	°C
Operating Temperature	T_g	0~70	°C
Storage Temperature Range	T_{STG}	-55~+150	°C

Recommended Operating Conditions

Parameter	Sym	Min	Max	Unit
Cathode Voltage	V_{KA}	V_{REF}	36	V
Cathode Current Range	I_K	1.0	100	mA

Electrical Characteristics @ 25°C Unless Otherwise Specified

Parameter	Sym	Min	Typ	Max	Test conditions
Reference Input Voltage	V_{ref}	2.475V	2.500V	2.525V	
Deviation of reference input voltage	$V_{ref(dev)}$		3.0mV	17mV	$T_{min} \leq T_a \leq T_{max}$
Ratio of Change in Reference Input Voltage to the Change in Cathode Voltage	$\frac{\Delta V_{ref}}{\Delta V_{KA}}$		-1.4	-2.7	$\Delta V_{KA}=10V \sim V_{ref}$
			-1.0	-2.0	$\Delta V_{KA}=36V \sim 10V$
Reference Input Current	I_{ref}		1.8µA	4.0µA	$I_{KA}=10mA, R_1=10K\Omega, R_2=\infty$
Deviation of Reference Input Current Over Full Temperature Range	$\frac{\Delta I_{ref}}{\Delta T}$		0.4µA	1.2µA	$I_{KA}=10mA, R_1=10K\Omega, R_2=\infty, T_A=full\ Temperature$
Minimum Cathode Current for Regulation	$I_{KA(min)}$		0.5mA	1.0mA	
Off-State Cathode Current	$I_{KA(off)}$		0.26µA	1.0µA	$V_{KA}=36V, V_{REF}=0V$
Dynamic Impedance	Z_{KA}		0.22Ω	0.5Ω	$I_{KA}=10\ to\ 100mA, f \leq 1.0KHz$

SOT-23

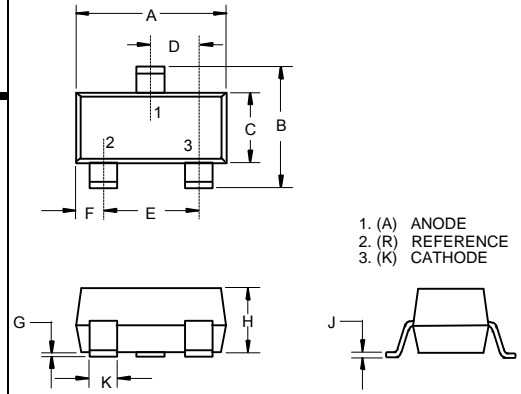

DIM	DIMENSIONS				NOTE
	INCHES		MM		
A	.110	.120	2.80	3.04	
B	.083	.104	2.10	2.64	
C	.047	.055	1.20	1.40	
D	.035	.041	.89	1.03	
E	.070	.081	1.78	2.05	
F	.018	.024	.45	.60	
G	.0005	.0039	.013	.100	
H	.035	.044	.89	1.12	
J	.003	.007	.085	.180	
K	.015	.020	.37	.51	

Suggested Solder Pad Layout

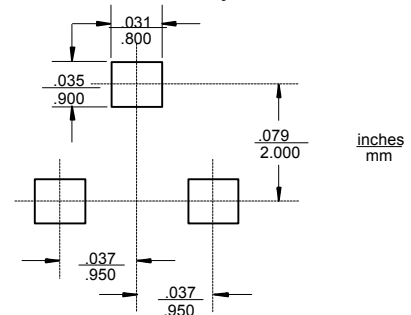

TL431AU

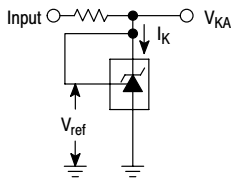

Figure 1. Test Circuit for $V_{KA} = V_{ref}$

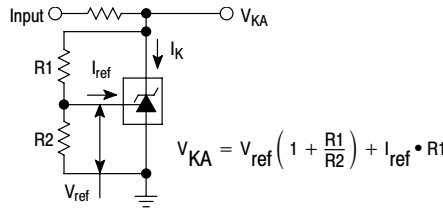

Figure 2. Test Circuit for $V_{KA} > V_{ref}$

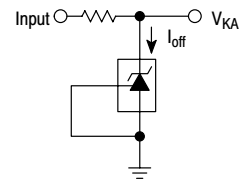

Figure 3. Test Circuit for I_{off}

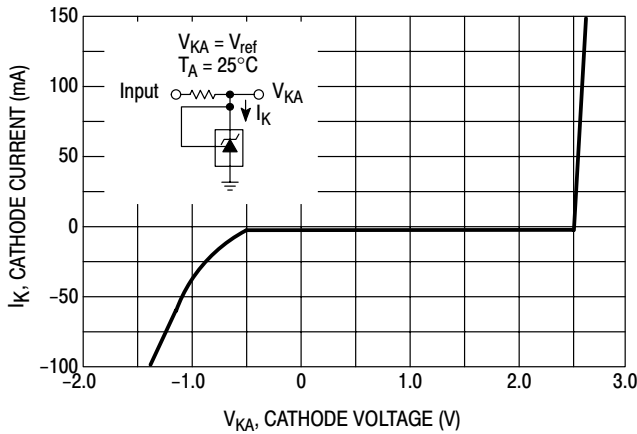

Figure 4. Cathode Current versus Cathode Voltage

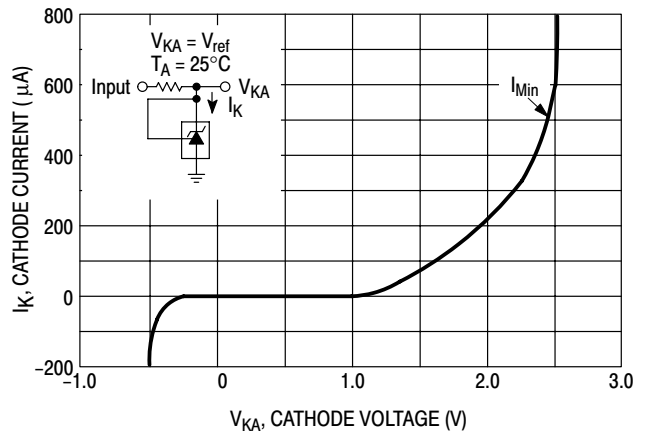

Figure 5. Cathode Current versus Cathode Voltage

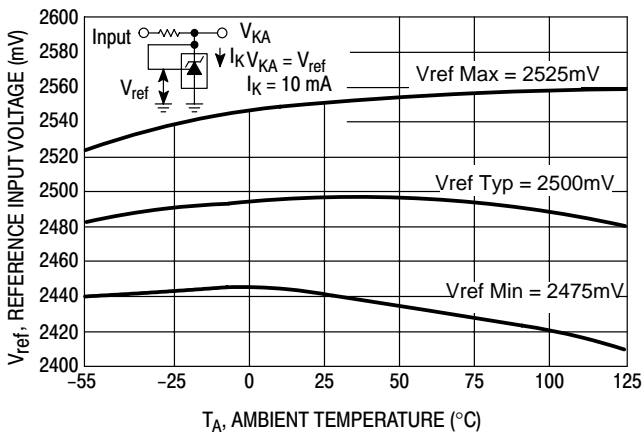

Figure 6. Reference Input Voltage versus Ambient Temperature

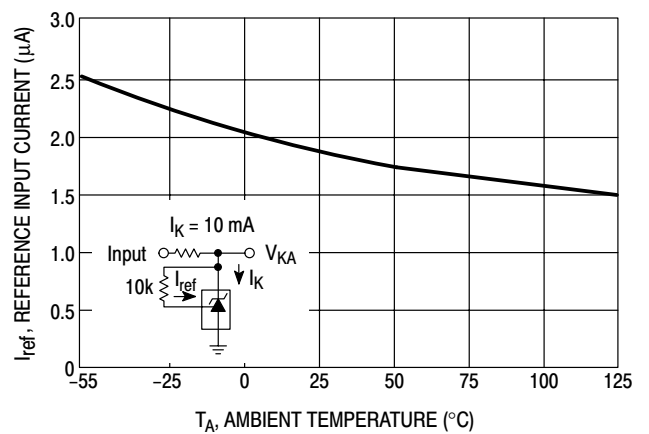

Figure 7. Reference Input Current versus Ambient Temperature

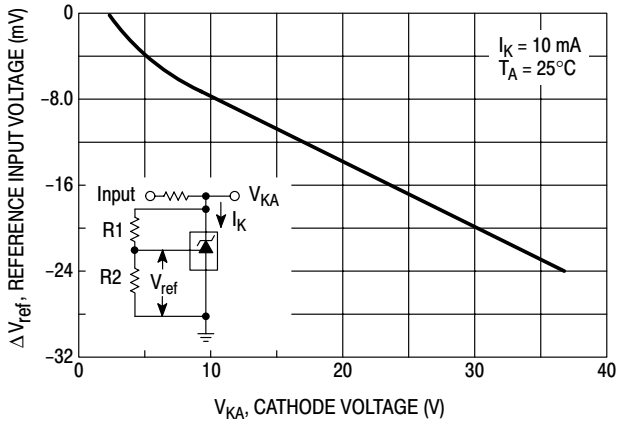

Figure 8. Change in Reference Input Voltage versus Cathode Voltage

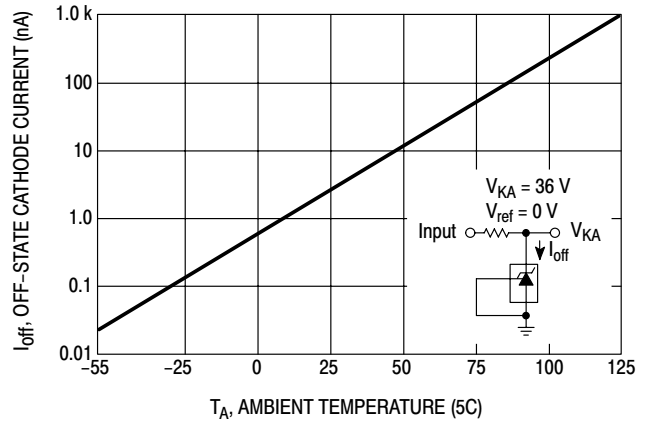

Figure 9. Off-State Cathode Current versus Ambient Temperature

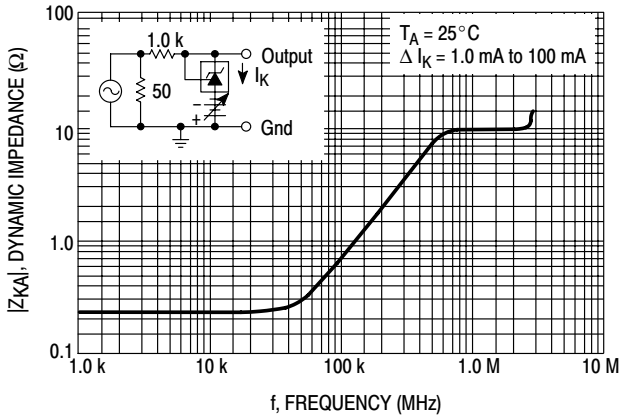

Figure 10. Dynamic Impedance versus Frequency

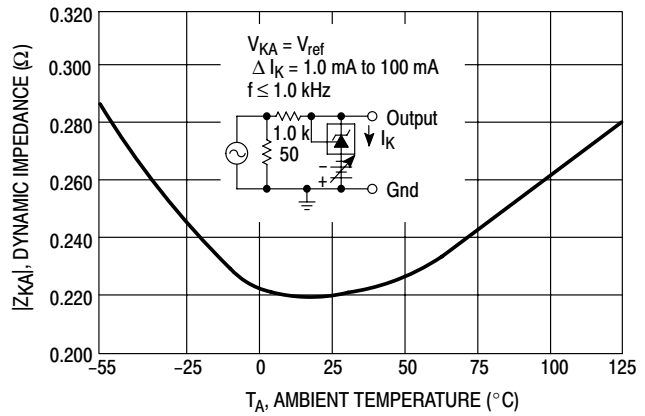

Figure 11. Dynamic Impedance versus Ambient Temperature

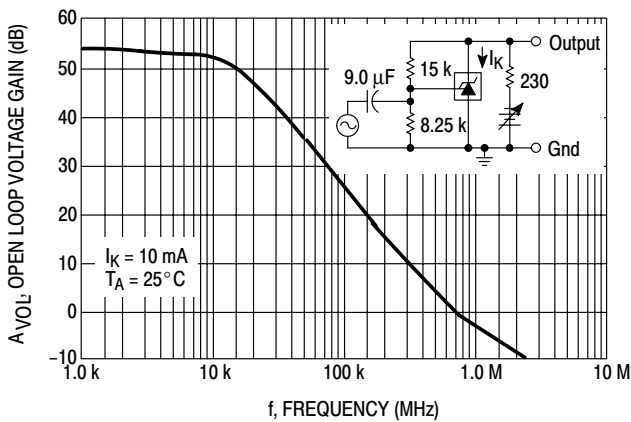

Figure 12. Open-Loop Voltage Gain versus Frequency

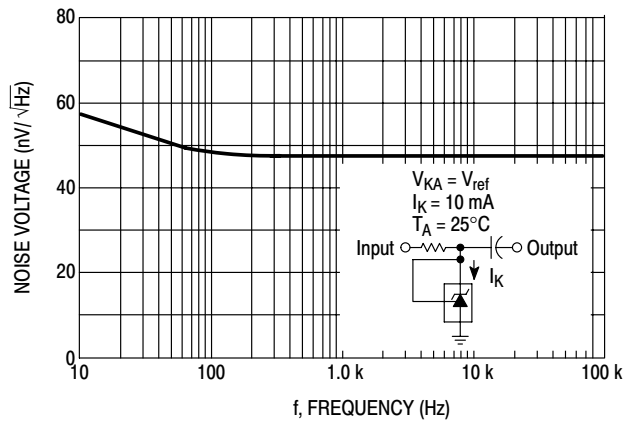

Figure 13. Spectral Noise Density



Micro Commercial Components

Ordering Information :

Device	Packing
Part Number-TP	Tape & Reel; 3 Kpcs/Reel

Note : Adding "-HF" suffix for halogen free, eg. Part Number-TP-HF

IMPORTANT NOTICE

Micro Commercial Components Corp. reserves the right to make changes without further notice to any product herein to make corrections, modifications, enhancements, improvements, or other changes. **Micro Commercial Components Corp.** does not assume any liability arising out of the application or use of any product described herein; neither does it convey any license under its patent rights, nor the rights of others. The user of products in such applications shall assume all risks of such use and will agree to hold **Micro Commercial Components Corp.** and all the companies whose products are represented on our website, harmless against all damages.

LIFE SUPPORT

MCC's products are not authorized for use as critical components in life support devices or systems without the express written approval of Micro Commercial Components Corporation.

CUSTOMER AWARENESS

Counterfeiting of semiconductor parts is a growing problem in the industry. Micro Commercial Components (MCC) is taking strong measures to protect ourselves and our customers from the proliferation of counterfeit parts. MCC strongly encourages customers to purchase MCC parts either directly from MCC or from Authorized MCC Distributors who are listed by country on our web page cited below. Products customers buy either from MCC directly or from Authorized MCC Distributors are genuine parts, have full traceability, meet MCC's quality standards for handling and storage. **MCC will not provide any warranty coverage or other assistance for parts bought from Unauthorized Sources.** MCC is committed to combat this global problem and encourage our customers to do their part in stopping this practice by buying direct or from authorized distributors.

www.mccsemi.com