

# 40MHz, 32-Channel Serial to Parallel Converter with Push-Pull Outputs

## Features

- ▶ HVCMOS® technology
- ▶ 5.0V logic and 12V supply rail
- ▶ Output voltage up to +200V
- ▶ Low power level shifting
- ▶ Source/sink current minimum 50mA
- ▶ 40MHz equivalent data rate
- ▶ Latched data outputs
- ▶ Forward and reverse shifting options (DIR pin)
- ▶ Chip select
- ▶ Polarity function

## General Description

The HV7620 is a low-voltage serial to high-voltage parallel converter with push-pull outputs. This device has been designed for use as a driver for color AC plasma displays.

The device has 4 parallel 8-bit shift registers permitting data rates four times the speed of one. The data is clocked in simultaneously on all four data inputs with a single clock. Data is shifted in on a low to high transition of the clock. The latches and control logic perform the output enable function.

The DIR pin causes clockwise (CW) shifting of the data when connected to VDD1, and counterclockwise (CCW) shifting when connected to LVGND. Operation of the shift register is not affected by the  $\overline{LE}$  (latch enable) input. Transfer of data from the shift registers to the latches occurs when the  $\overline{LE}$  input is high. Data is stored in the latches when  $\overline{LE}$  is low. The current source on the logic inputs provides active pull up when the input pins are open.

## Functional Block Diagram

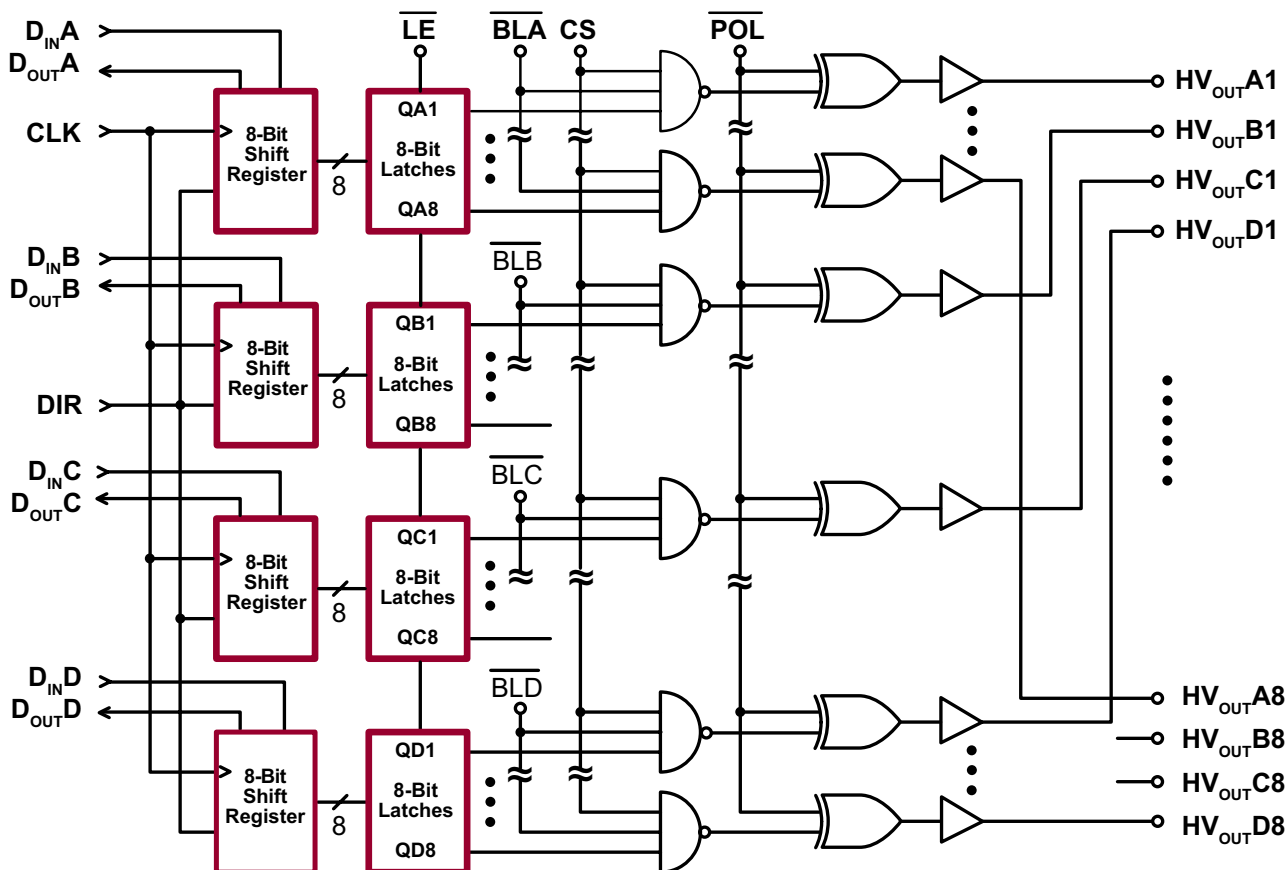

## Ordering Information / Availability

Part Number	Package Option	Packing
HV7620PG-G	64-Lead PQFP (3-sided)	66/tray

-G denotes a lead (Pb)-free / RoHS compliant package



## Pin Configuration

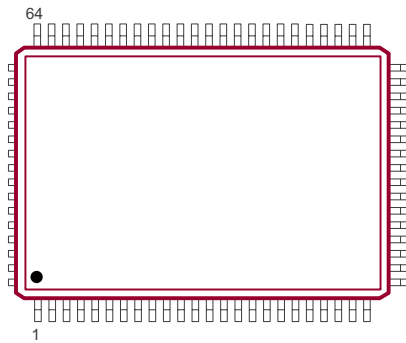

64-Lead PQFP (3-sided)  
(top view)

## Absolute Maximum Ratings

Parameter	Value
Supply voltage, $V_{DD1}$	-0.5V to +15V
Supply voltage, $V_{DD2}$	-0.5V to +15V
Supply voltage, $V_{PP}$	-0.5V to +225V
Logic input levels	-2.0V to $V_{DD1} + 2.0V$
Continuous total power dissipation <sup>1</sup>	1200mW
Operating temperature range	-40°C to +85°C
Storage temperature range	-65°C to +150°C

Absolute Maximum Ratings are those values beyond which damage to the device may occur. Functional operation under these conditions is not implied. Continuous operation of the device at the absolute rating level may affect device reliability. All voltages are referenced to device ground.

### Notes:

- For operation above 25°C ambient derate linearly to maximum operating temperature at 20mW/°C.

## Product Marking

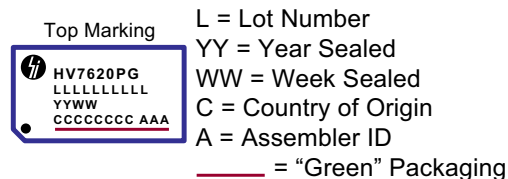

Package may or may not include the following marks: Si or

64-Lead PQFP (3-sided)

## Typical Thermal Resistance

Package	$\theta_{ja}$
64-Lead PQFP	41°C/W

## Recommended Operating Conditions

Sym	Parameter	Min	Max	Units	
$V_{DD1}$	Logic supply voltage	4.5	$V_{DD2}$	V	
$V_{DD2}$	12V supply voltage	10.8	13.2	V	
$V_{PP}$	High voltage supply voltage	50	200	V	
$V_{IH}$	High-level input voltage	$V_{DD1} - 0.5V$	$V_{DD1}$	V	
$V_{IL}$	Low-level input voltage	0	0.5	V	
$f_{CLK}$	Clock frequency	$V_{DD1} = 5.0V$	-	10	MHz
		$V_{DD1} = 12V$	-	5	MHz
$T_A$	Operating temperature range	-40	+85	°C	
$I_{OD}$	Allowable pulsed current through output diodes <sup>1</sup>	-	500	mA	
$I_{GND(VPP)}$	Allowable pulsed $V_{PP}$ or HVGND current <sup>1</sup>	-	16	A	
$V_{PP(SLEW)}$	Slew rate of $V_{PP}$	-	340	V/μs	

### Notes:

- The current pulse width = 500ns, duty cycle = 5%.

## DC Electrical Characteristics

(Over operating supply voltages and temperature, unless otherwise noted,  $V_{DD1} = 5.0V$ ,  $V_{DD2} = 12V$ ,  $V_{PP} = 200V$  and  $T_A = 25^\circ C$ )

Sym	Parameter	Min	Max	Units	Conditions	
$I_{DD1}$	$V_{DD1}$ supply current	-	5.0	mA	$f_{CLK} = 10MHz$	
$I_{DD2}$	$V_{DD2}$ supply current	-	20	mA	$V_{DD2} = 13.2V$ , $f_{CLK} = 10MHz$	
$I_{PP}$	High voltage supply current	-	2.0	mA	All outputs high or low	
$I_{DD1Q}$	Quiescent $V_{DD1}$ supply current	-	100	$\mu A$	All input = $V_{DD1}$	
$I_{DD2Q}$	Quiescent $V_{DD2}$ supply current	-	100	$\mu A$	All input = $V_{DD1}$	
$V_{OH}$	High-level output	HV <sub>OUT</sub>	185	-	V	$I_O = -50mA$
		Data OUT	$V_{DD} - 1$	-		$I_O = -100\mu A$
$V_{OL}$	Low-level output	HV <sub>OUT</sub>	-	20	V	$I_O = +50mA$
		Data OUT	-	1.0		$I_O = +100\mu A$
$I_{IH}$	High-level logic input current	-	1.0	$\mu A$	$V_{IN} = V_{DD1}$	
$I_{IL}$	Low-level logic input current	-	-10	$\mu A$	$V_{IN} = 0V$	
$V_{GG}$	HVGND to LVGND voltage difference	-1.0	1.0	V	---	

## AC Electrical Characteristics

(Logic signal inputs and data inputs have  $t_r, t_f \leq 5ns$ .  $V_{DD1} = 5.0V$  or  $12V$ ,  $V_{DD2} = 12V$ ,  $V_{PP} = 200V$ )

Sym	Parameter	Min	Max	Units	Conditions	
$f_{CLK}$	Clock frequency	$V_{DD1} = 5.0V$	-	10	MHz	Per register, $C_L = 15pF$
		$V_{DD1} = 12V$	-	5.0		
$t_{WL}, t_{WH}$	Clock width high or low	40	-	ns	---	
$t_{SU}$	Data set-up time before clock rises	20	-	ns	---	
$t_H$	Data hold time after clock rises	20	-	ns	---	
$t_{ON}, t_{OFF}$	Time from latch enable to HV <sub>OUT</sub>	-	275	ns	$C_L = 15pF$	
$t_{WLE}$	$\overline{LE}$ pulse width	25	-	ns	---	
$t_{DLE}$	Delay time clock to $\overline{LE}$ low to high	50	-	ns	---	
$t_{SLE}$	$\overline{LE}$ set-up time before clock rises	20	-	ns	---	
$t_{DLF}, t_{DLN}$	$\overline{BL}$ or CS low to high to HV <sub>OUT</sub>	-	250	ns	---	
$t_{COF}, t_{CON}$	Clock to HV <sub>OUT</sub>	-	275	ns	---	
$t_{DLH}$	Delay time clock to data low to high	-	100	ns	$C_L = 15pF$	
$t_{DHL}$	Delay time clock to data high to low	-	100	ns	$C_L = 15pF$	

### Input and Output Equivalent Circuits

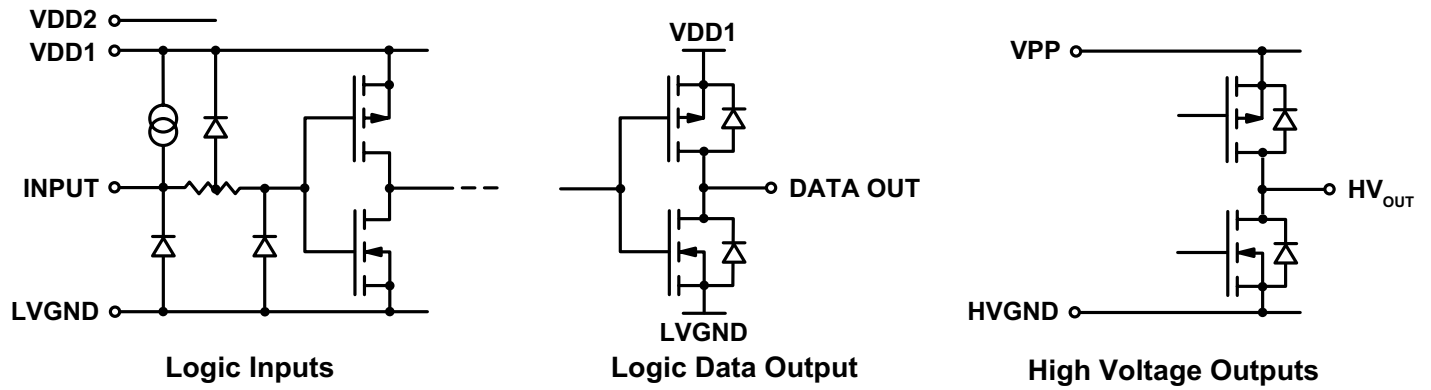

### Switching Waveforms

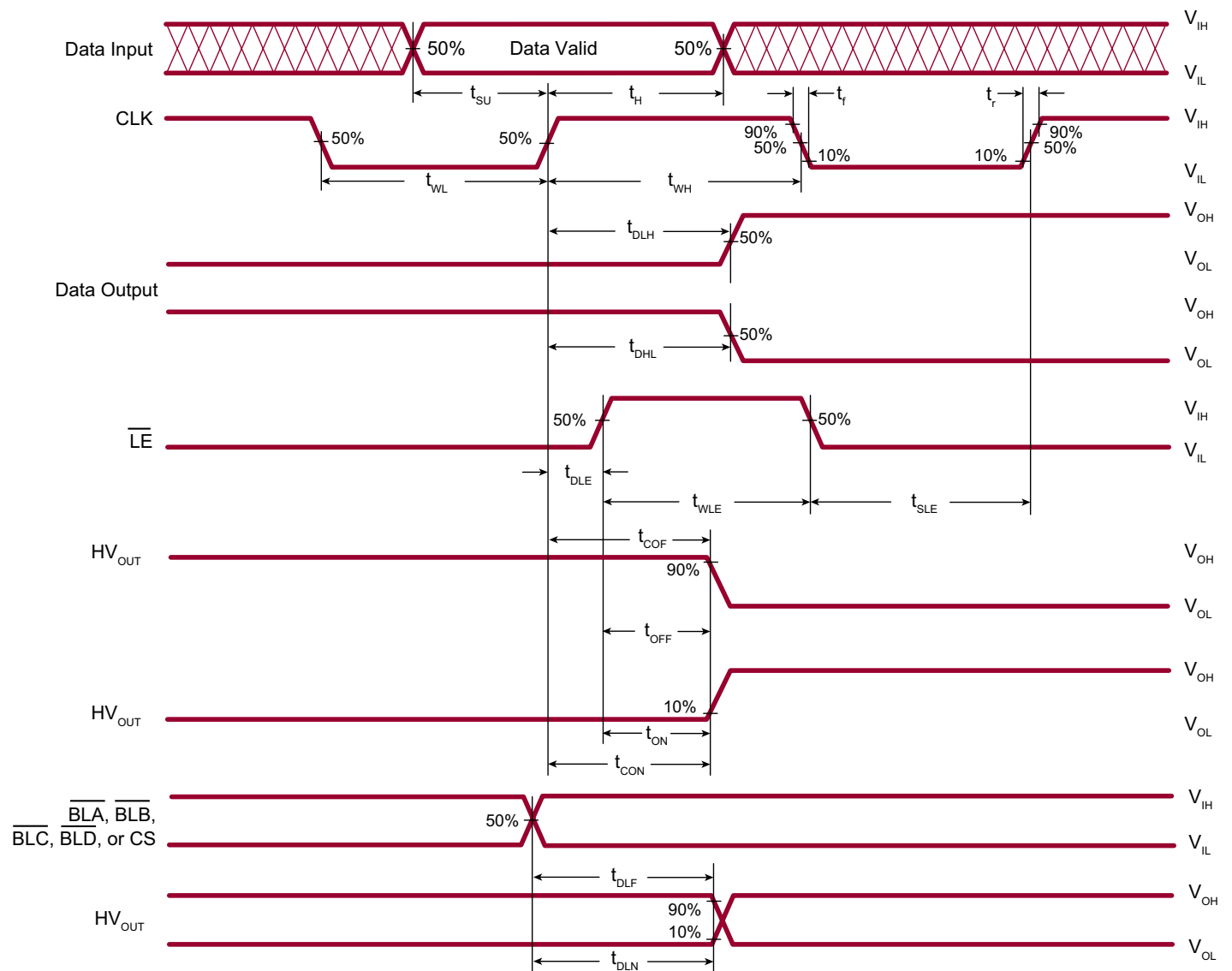

Function Table

Function	Inputs													HV <sub>OUT</sub>			
	D <sub>IN</sub> A	D <sub>IN</sub> B	D <sub>IN</sub> C	D <sub>IN</sub> D	CLK	$\overline{LE}$	DIR	$\overline{BLA}$	$\overline{BLB}$	$\overline{BLC}$	$\overline{BLD}$	CS	$\overline{POL}$	A	B	C	D
All O/P High	X	X	X	X	X	X	X	X	X	X	X	L	L	H	H	H	H
All O/P Low	X	X	X	X	X	X	X	X	X	X	X	L	H	L	L	L	L
“A”↑ Outputs Low	X	X	X	X	X	X	X	L	X	X	X	X	H	L	*	*	*
Normal Polarity	X	X	X	X	X	X	X	H	H	H	H	H	H	No Inversion			
Outputs Inverted	X	X	X	X	X	X	X	H	H	H	H	H	L	Inversion			
Transparent Mode	H	L	L	L	↑	H	X	H	H	H	H	H	H	H	L	L	L
Data Stored	X	X	X	X	X	L	X	H	H	H	H	H	H	Stored data			
Shift CW <sup>A</sup>	X	X	X	X	↑	H	H	H	H	H	H	H	X	A <sub>N</sub> → A <sub>N+1</sub>	B <sub>N</sub> → B <sub>N+1</sub>	C <sub>N</sub> → C <sub>N+1</sub>	D <sub>N</sub> → D <sub>N+1</sub>
Shift CCW <sup>B</sup>	X	X	X	X	↑	H	L	H	H	H	H	H	X	A <sub>N</sub> → A <sub>N-1</sub>	B <sub>N</sub> → B <sub>N-1</sub>	C <sub>N</sub> → C <sub>N-1</sub>	D <sub>N</sub> → D <sub>N-1</sub>

Notes:

- H = High level, L = Low level, X = Irrelevant, ↑ = Low to high transition.
- \* = Dependent on previous stage's state before the last CLK ↑ for last  $\overline{LE}$  high.
- ↑ =  $\overline{BLB}$ ,  $\overline{BLC}$  and  $\overline{BLD}$  will have similar effect on their respective output.
- A = When Shift CW is selected, D<sub>IN</sub> is input and D<sub>OUT</sub> is output.
- B = When Shift CCW is selected, D<sub>IN</sub> is output and D<sub>OUT</sub> is input.

Power-up sequence:

1. GND (HV, LV)
2. V<sub>DD1</sub>
3. V<sub>DD2</sub>
4. V<sub>PP</sub>
5. Logic Input Signals

To power down reverse the sequence above.

**Pin Function**

Pin #	Function
1	HVGND
2	VPP
3	HV <sub>OUT</sub> D8
4	HV <sub>OUT</sub> C8
5	HV <sub>OUT</sub> B8
6	HV <sub>OUT</sub> A8
7	HV <sub>OUT</sub> D7
8	HV <sub>OUT</sub> C7
9	HV <sub>OUT</sub> B7
10	HV <sub>OUT</sub> A7
11	HV <sub>OUT</sub> D6
12	HV <sub>OUT</sub> C6
13	HV <sub>OUT</sub> B6
14	HV <sub>OUT</sub> A6
15	HV <sub>OUT</sub> D5
16	HV <sub>OUT</sub> C5

Pin #	Function
17	HV <sub>OUT</sub> B5
18	HV <sub>OUT</sub> A5
19	VPP
20	HVGND
21	HVGND
22	VDD2
23	$\overline{\text{BLC}}$
24	$\overline{\text{BLD}}$
25	$\overline{\text{LE}}$
26	D <sub>OUT</sub> D
27	D <sub>IN</sub> D
28	D <sub>IN</sub> C
29	D <sub>OUT</sub> C
30	$\overline{\text{POL}}$
31	LVGND
32	DIR

Pin #	Function
33	CS
34	D <sub>OUT</sub> B
35	D <sub>IN</sub> B
36	D <sub>IN</sub> A
37	D <sub>OUT</sub> A
38	CLK
39	$\overline{\text{BLA}}$
40	$\overline{\text{BLB}}$
41	VDD1
42	LVGND
43	N/C
44	HVGND
45	HVGND
46	VPP
47	HV <sub>OUT</sub> D4
48	HV <sub>OUT</sub> C4

Pin #	Function
49	HV <sub>OUT</sub> B4
50	HV <sub>OUT</sub> A4
51	HV <sub>OUT</sub> D3
52	HV <sub>OUT</sub> C3
53	HV <sub>OUT</sub> B3
54	HV <sub>OUT</sub> A3
55	HV <sub>OUT</sub> D2
56	HV <sub>OUT</sub> C2
57	HV <sub>OUT</sub> B2
58	HV <sub>OUT</sub> A2
59	HV <sub>OUT</sub> D1
60	HV <sub>OUT</sub> C1
61	HV <sub>OUT</sub> B1
62	HV <sub>OUT</sub> A1
63	VPP
64	HVGND

# 64-Lead PQFP (3-Sided) Package Outline (PG)

20.00x14.00mm body, 3.40mm height (max), 0.80mm pitch, 3.90mm footprint

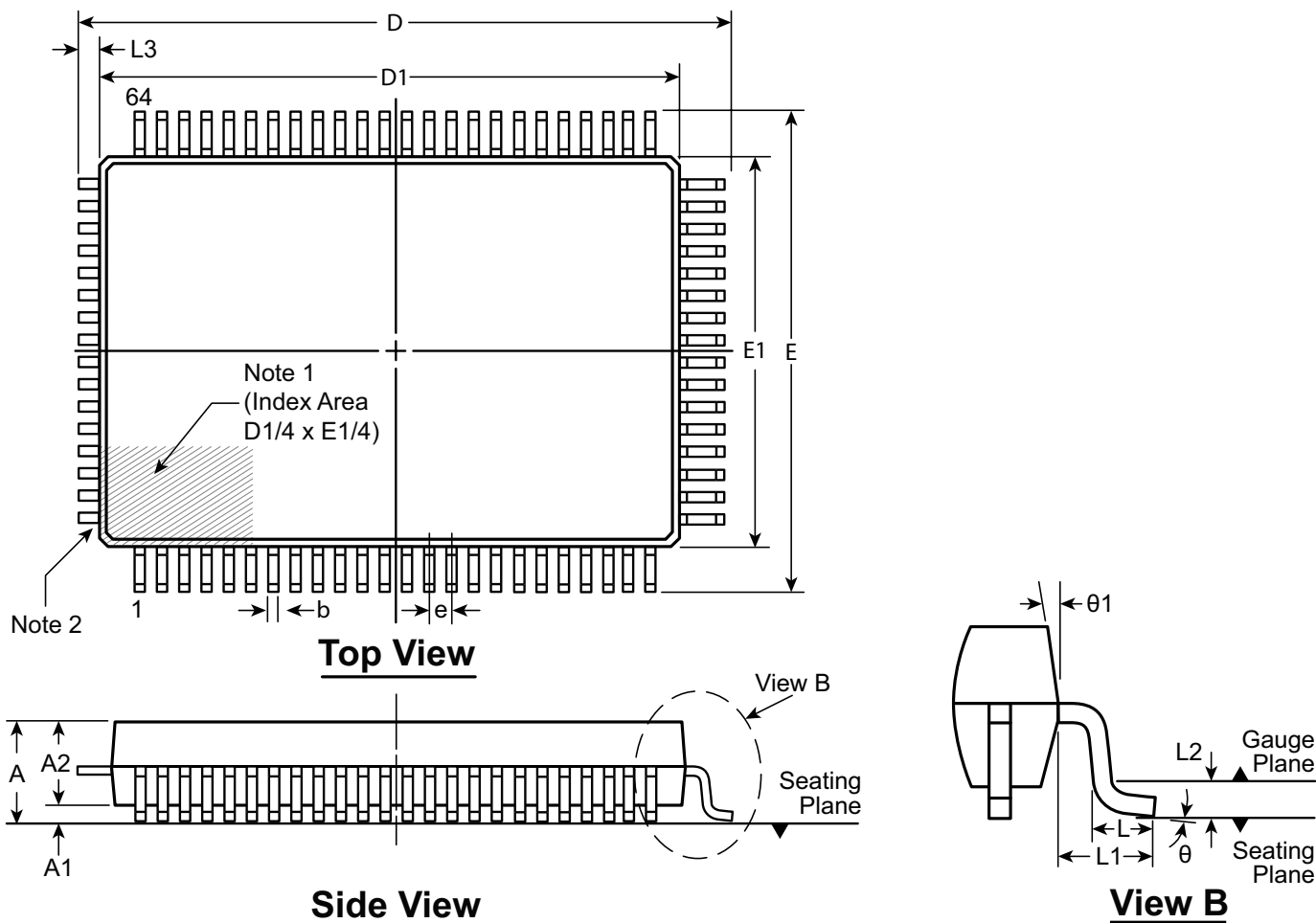

- Note:**
1. A Pin 1 identifier must be located in the index area indicated. The Pin 1 identifier can be: a molded mark/identifier; an embedded metal marker; or a printed indicator.
  2. The leads on this side are trimmed.

Symbol	A	A1	A2	b	D	D1	E	E1	e	L	L1	L2	L3	θ	θ1	
Dimension (mm)	MIN	2.80	0.25	2.55	0.30	22.25	19.80	17.65	13.80	0.80 BSC	0.73	1.95 REF	0.25 BSC	0.55 REF	0°	5°
	NOM	-	-	2.80	-	22.50	20.00	17.90	14.00		0.88				3.5°	-
	MAX	3.40	0.50	3.05	0.45	22.75	20.20	18.15	14.20		1.03				7°	16°

Drawings not to scale.

Supertex Doc. #: DSPD-64PQFPPG, Version A080812.

(The package drawing(s) in this data sheet may not reflect the most current specifications. For the latest package outline information go to <http://www.supertex.com/packaging.html>.)

**Supertex inc.** does not recommend the use of its products in life support applications, and will not knowingly sell them for use in such applications unless it receives an adequate "product liability indemnification insurance agreement." **Supertex inc.** does not assume responsibility for use of devices described, and limits its liability to the replacement of the devices determined defective due to workmanship. No responsibility is assumed for possible omissions and inaccuracies. Circuitry and specifications are subject to change without notice. For the latest product specifications refer to the **Supertex inc.** (website: <http://www.supertex.com>)