

32MHz, 64-Channel Serial to Parallel Converter with Push-Pull Outputs

Features

- ▶ HVCMOS® technology
- ▶ 5.0V CMS Logic
- ▶ Output voltage up to +80V
- ▶ Low power level shifting
- ▶ 32MHz equivalent data rate
- ▶ Latched data outputs
- ▶ Forward and reverse shifting options (DIR pin)
- ▶ Diode to VPP allows efficient power recovery
- ▶ Outputs may be hot switched
- ▶ Hi-Rel processing available

General Description

The HV57708 is a low voltage serial to high voltage parallel converter with push-pull outputs. The device has been designed for use as a driver for EL displays. It can also be used in any application requiring multiple output high voltage current sourcing and sinking capability such

as driving plasma panels, vacuum fluorescent displays, or large matrix LCD displays.

The device has 4 parallel 16-bit registers, permitting data rates 4x the speed of one (they are clocked together). There are also 64 latches and control logic to perform the polarity select and blanking of the outputs. HV_{OUT}1 is connected to the first stage of the first shift register through the polarity and blanking logic. Data is shifted through the shift registers on the logic low to high transition of the clock. The DIR pin causes CCW shifting when connected to GND, and CW shifting when connected to VDD. A data output buffer is provided for cascading devices. This output reflects the current status of the last bit of the shift register (HV_{OUT}64). Operation of the shift register is not affected by the LE (latch enable), BL (blanking), or the POL (polarity) inputs. Transfer of data from the shift registers to the latches occurs when the LE input is high. The data in the latches is stored when the LE is low.

Functional Block Diagram

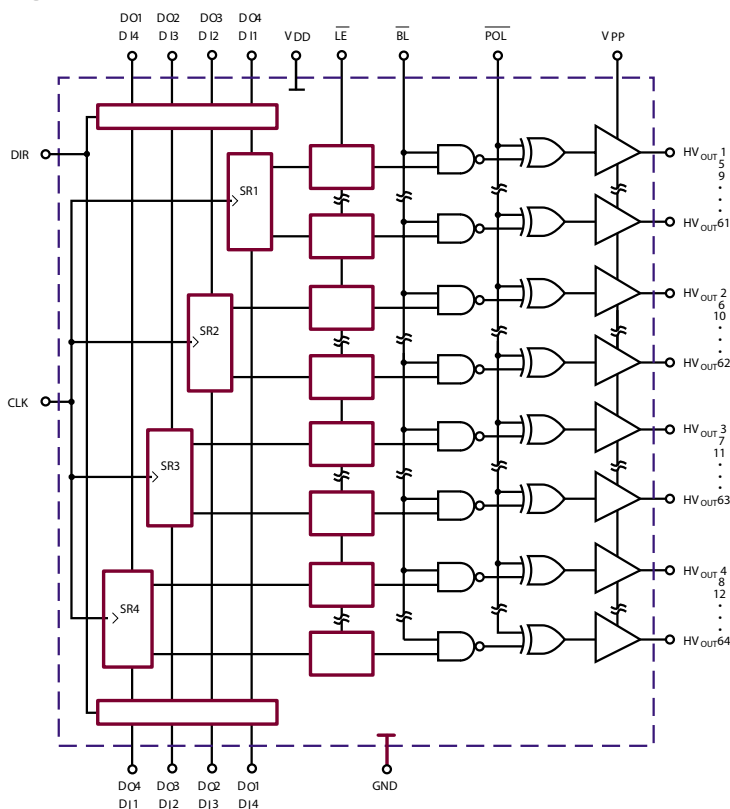

Note:
Each SR (shift register) provides 16 outputs. SR1 supplies every fourth output starting with 1; SR2 supplies every fourth output with 2, etc.

Ordering Information

Device	Package Options
	80-Lead PQFP 20.00x14.00mm body 3.40mm height (max) 0.80mm pitch
HV57708	HV57708PG-G

-G indicates package is RoHS compliant ("Green")



Absolute Maximum Ratings

Parameter	Value
Supply voltage, V_{DD}	-0.5V to +7.5V
Output voltage, V_{PP}	-0.5V to +90V
Logic input levels	-0.3V to $V_{DD} + 0.3V$
Ground current ¹	1.5A
Continuous total power dissipation ²	1200mW
Operating temperature range	-40°C to +85°C
Storage temperature range	-65°C to +150°C
Lead temperature ³	260°C

Absolute Maximum Ratings are those values beyond which damage to the device may occur. Functional operation under these conditions is not implied. Continuous operation of the device at the absolute rating level may affect device reliability. All voltages are referenced to device ground.

Notes:

- Limited by the total power dissipated in the package.
- For operation above 25°C ambient derate linearly to maximum operating temperature at 20mW/°C.
- 1.6mm (1/16inch) from case for 10 seconds.

Pin Configuration

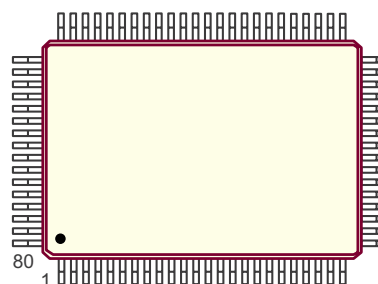

80-Lead PQFP (PG)
(top view)

Product Marking

Top Marking

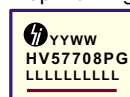

YY = Year Sealed
 WW = Week Sealed
 L = Lot Number
 C = Country of Origin*
 A = Assembler ID*
 _____ = "Green" Packaging

Bottom Marking

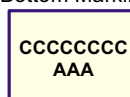

*May be part of top marking

80-Lead PQFP (PG)

Recommended Operating Conditions

Sym	Parameter	Min	Max	Units
V_{DD}	Logic supply voltage	4.5	5.5	V
V_{PP}	Output voltage	8.0	80	V
V_{IH}	High-level input voltage	$V_{DD} - 0.5V$	-	V
V_{IL}	Low-level input voltage	0	0.5	V
f_{CLK}	Clock frequency per register	-	8.0	MHz
T_A	Operating free-air temperature	-40	+85	°C

Notes:

Power-up sequence should be the following:

- Apply ground.
- Apply V_{DD} .
- Set all inputs (D_{IN} , CLK, Enable, etc.) to a known state.
- Apply V_{PP} .
- The V_{PP} should not drop below V_{DD} or float during operation.

Power-down sequence should be the reverse of the above.

DC Electrical Characteristics (Over recommended operating conditions unless otherwise noted)

Sym	Parameter	Min	Max	Units	Conditions	
I_{DD}	V_{DD} supply current	-	15	mA	$V_{DD} = V_{DD} \text{ max}, f_{CLK} = 8.0\text{MHz}$	
I_{PP}	High voltage supply current	-	100	μA	Outputs high	
		-	100	μA	Outputs low	
I_{DDQ}	Quiescent V_{DD} supply current	-	100	μA	All $V_{IN} = V_{DD}$	
V_{OH}	High level output	HV_{OUT}	65	-	V	$I_O = -15\text{mA}, V_{PP} = +80\text{V}$
		Data out	$V_{DD} - 0.5$	-	V	$I_O = -100\mu\text{A}$
V_{OL}	Low level output	HV_{OUT}	-	7.0	V	$I_O = 12\text{mA}, V_{PP} = +80\text{V}$
		Data out	-	0.5	V	$I_O = 100\mu\text{A}$
I_{IH}	High-level logic input current	-	1.0	μA	$V_{IH} = V_{DD}$	
I_{IL}	Low-level logic input current	-	-1.0	μA	$V_{IL} = 0\text{V}$	
V_{OC}	High voltage clamp diode	-	1.0	V	$I_{OC} = 1.0\text{mA}$	

AC Electrical Characteristics ($T_A = 85^\circ\text{C max}$. Logic signal inputs and Data inputs have $t_r, t_f \leq 5\text{ns}$ [10% and 90% points])

Sym	Parameter	Min	Max	Units	Conditions
f_{CLK}	Clock frequency	-	8.0	MHz	Per register
t_{WL}, t_{WH}	Clock width high or low	62	-	ns	---
t_{SU}	Data set-up time before clock rises	10	-	ns	---
t_H	Data hold time after clock rises	15	-	ns	---
t_{ON}, t_{OFF}	Time from latch enable to HV_{OUT}	-	500	ns	$C_L = 15\text{pF}$
t_{DHL}	Delay time clock to data high to low	-	70	ns	$C_L = 15\text{pF}$
t_{DLH}	Delay time clock to data low to high	-	70	ns	$C_L = 15\text{pF}$
t_{DLE}^*	Delay time clock to \overline{LE} low to high	25	-	ns	---
t_{WLE}	\overline{LE} pulse width	25	-	ns	---
t_{SLE}	\overline{LE} set-up time before clock rises	0	-	ns	---

* t_{DLE} is not required but is recommended to produce stable HV outputs and thus minimize power dissipation and current spikes (allows internal SR output to stabilize).

Input and Output Equivalent Circuits

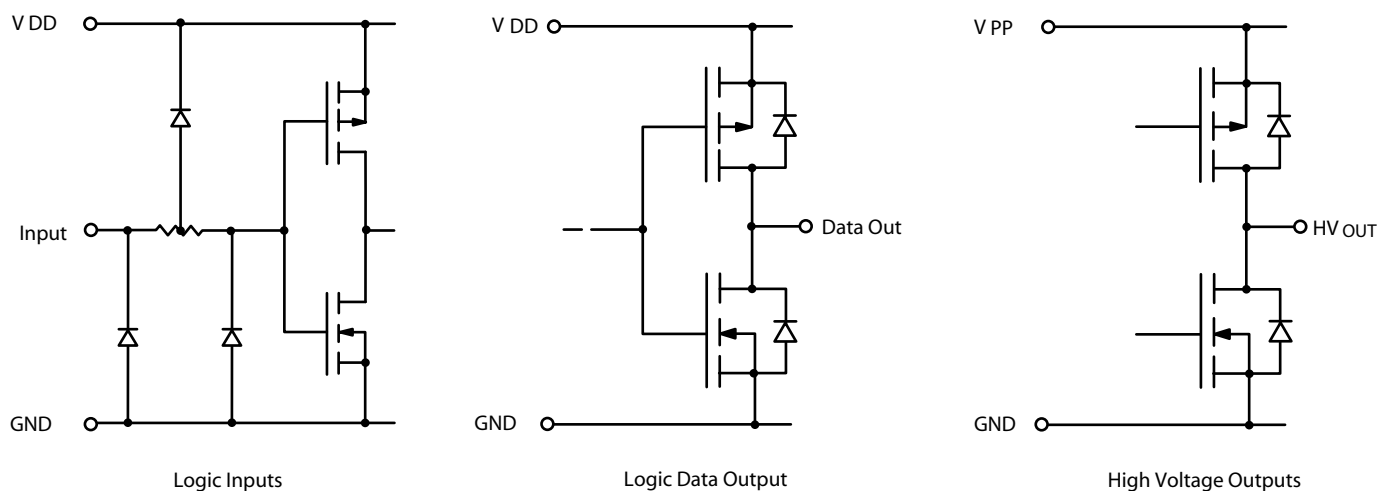

Switching Waveforms

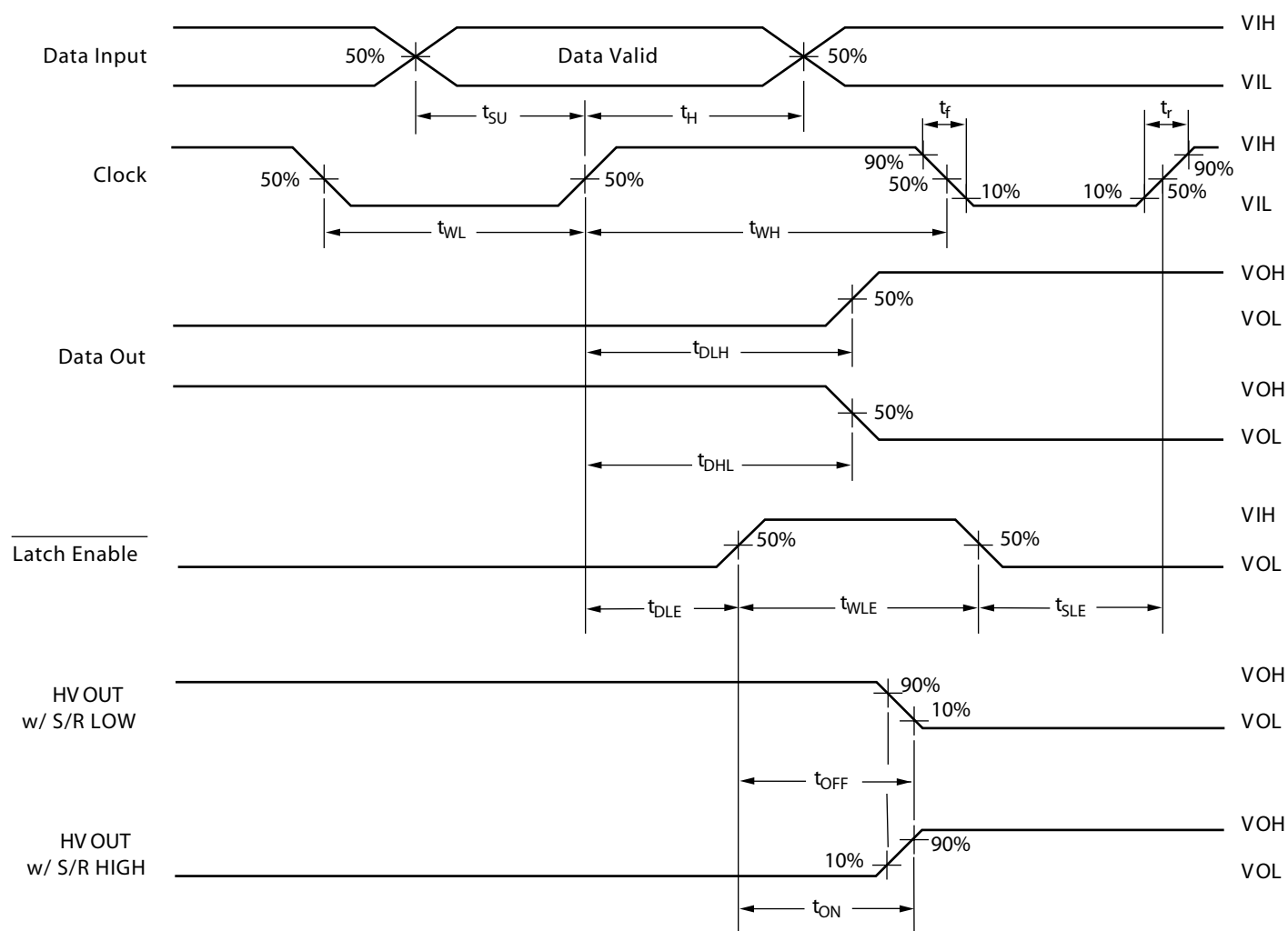

Function Table

Function	Inputs						Outputs		
	Data	CLK	\overline{LE}	\overline{BL}	\overline{POL}	DIR	Shift Reg	HV Outputs	Data Out
All O/P high	X	X	X	L	L	X	-	H	-
All O/P low	X	X	X	L	H	X	-	L	-
O/P normal	X	X	X	H	H	X	-	No inversion	-
O/P inverted	X	X	X	H	L	X	-	Inversion	-
Data falls through (latches transparent)	L	$\overline{\uparrow}$	H	H	H	X	L	L	-
	H	$\overline{\uparrow}$	H	H	H	X	H	H	-
	L	$\overline{\uparrow}$	H	H	L	X	L	H	-
	H	$\overline{\uparrow}$	H	H	L	X	H	L	-
Data stored/ latches loaded	X	X	L	H	H	X	*	Stored Data	-
	X	X	L	H	L	X	*	Inversion of stored data	-
I/O relation	D _{I/O} 1-4A	$\overline{\uparrow}$	H	H	H	H	Q _n →Q _{n+1}	New H or L	D _{I/O} 1-4B
	D _{I/O} 1-4A	$\overline{\uparrow}$	L	H	H	H	Q _n →Q _{n+1}	Previous H or L	D _{I/O} 1-4B
	D _{I/O} 1-4B	$\overline{\uparrow}$	L	H	H	L	Q _n →Q _{n-1}	Previous H or L	D _{I/O} 1-4A
	D _{I/O} 1-4B	$\overline{\uparrow}$	H	H	H	L	Q _n →Q _{n-1}	New H or L	D _{I/O} 1-4A

Note:

* = dependent on previous stage's state. See Pin configuration for DIN and DOUT pin designation for CW and CCW shift.

Shift Register Operation

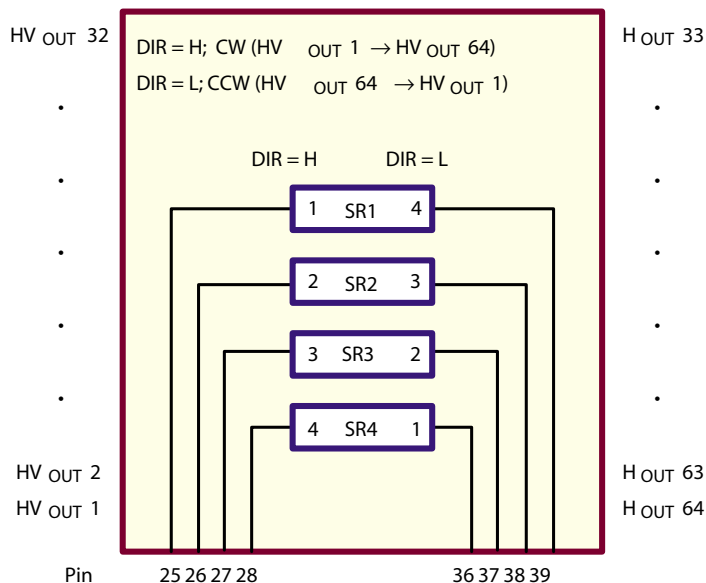

Pin Function

Pin #	Function	Pin #	Function	Pin #	Function	Pin #	Function
1	HV _{OUT} 24/41	21	HV _{OUT} 4/61	41	HV _{OUT} 64/1	61	HV _{OUT} 44/21
2	HV _{OUT} 23/42	22	HV _{OUT} 3/62	42	HV _{OUT} 63/2	62	HV _{OUT} 43/22
3	HV _{OUT} 22/43	23	HV _{OUT} 2/63	43	HV _{OUT} 62/3	63	HV _{OUT} 42/23
4	HV _{OUT} 21/44	24	HV _{OUT} 1/64	44	HV _{OUT} 61/4	64	HV _{OUT} 41/24
5	HV _{OUT} 20/45	25	D _{IN} 1/D _{OUT} 4(A)	45	HV _{OUT} 60/5	65	HV _{OUT} 40/25
6	HV _{OUT} 19/46	26	D _{IN} 2/D _{OUT} 3(A)	46	HV _{OUT} 59/6	66	HV _{OUT} 39/26
7	HV _{OUT} 18/47	27	D _{IN} 3/D _{OUT} 2(A)	47	HV _{OUT} 58/7	67	HV _{OUT} 38/27
8	HV _{OUT} 17/48	28	D _{IN} 4/D _{OUT} 1(A)	48	HV _{OUT} 57/8	68	HV _{OUT} 37/28
9	HV _{OUT} 16/49	29	\overline{LE}	49	HV _{OUT} 56/9	69	HV _{OUT} 36/29
10	HV _{OUT} 15/50	30	CLK	50	HV _{OUT} 55/10	70	HV _{OUT} 35/30
11	HV _{OUT} 14/51	31	\overline{BL}	51	HV _{OUT} 54/11	71	HV _{OUT} 34/31
12	HV _{OUT} 13/52	32	VDD	52	HV _{OUT} 53/12	72	HV _{OUT} 33/32
13	HV _{OUT} 12/53	33	DIR	53	HV _{OUT} 52/13	73	HV _{OUT} 32/33
14	HV _{OUT} 11/54	34	GND	54	HV _{OUT} 51/14	74	HV _{OUT} 31/34
15	HV _{OUT} 10/55	35	\overline{POL}	55	HV _{OUT} 50/15	75	HV _{OUT} 30/35
16	HV _{OUT} 9/56	36	D _{OUT} 4/D _{IN} 1(B)	56	HV _{OUT} 49/16	76	HV _{OUT} 29/36
17	HV _{OUT} 8/57	37	D _{OUT} 3/D _{IN} 2(B)	57	HV _{OUT} 48/17	77	HV _{OUT} 28/37
18	HV _{OUT} 7/58	38	D _{OUT} 2/D _{IN} 3(B)	58	HV _{OUT} 47/18	78	HV _{OUT} 27/38
19	HV _{OUT} 6/59	39	D _{OUT} 1/D _{IN} 4(B)	59	HV _{OUT} 46/19	79	HV _{OUT} 26/39
20	HV _{OUT} 5/60	40	VPP	60	HV _{OUT} 45/20	80	HV _{OUT} 25/40

Note:

Pin designation for DIR = H/L.

Example: For DIR = H, pin 41 is HV_{OUT}64.

For DIR = L, pin 41 is HV_{OUT}1.

For CW/CCW Shift see function table $Q_N \rightarrow Q_{N+1}$.

80-Lead PQFP Package Outline (PG)

20.00x14.00mm body, 3.40mm height (max), 0.80mm pitch, 3.90mm footprint

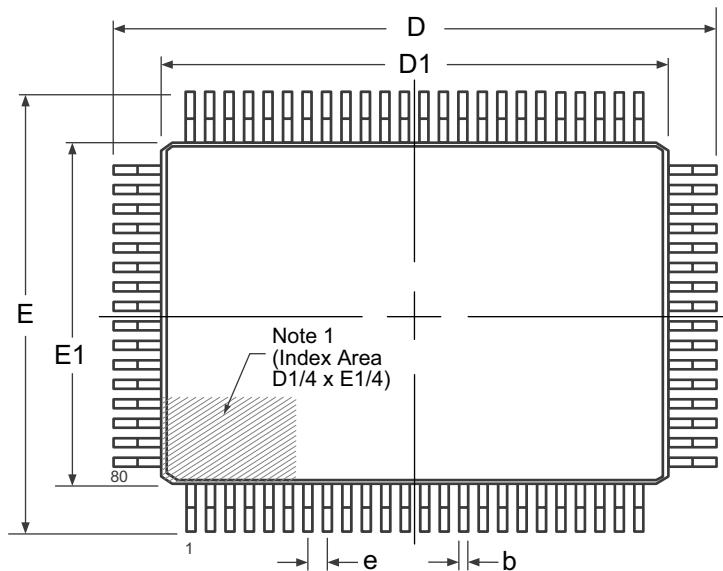

Top View

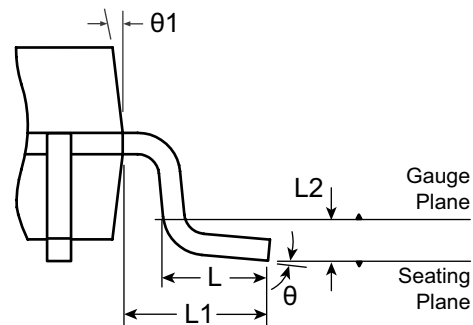

View B

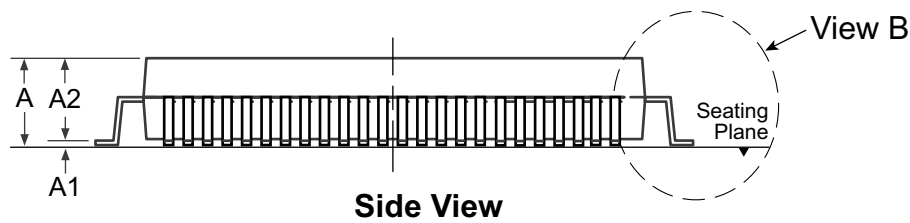

Side View

Note:
 1. A Pin 1 identifier must be located in the index area indicated. The Pin 1 identifier can be: a molded mark/identifier; an embedded metal marker; or a printed indicator.

Symbol	A	A1	A2	b	D	D1	E	E1	e	L	L1	L2	θ	θ1	
Dimension (mm)	MIN	2.80*	0.25	2.55	0.30	23.65*	19.80*	17.65*	13.80*	0.80 BSC	0.73	1.95 REF	0.25 BSC	0°	5°
	NOM	-	-	2.80	-	23.90	20.00	17.90	14.00		0.88			3.5°	-
	MAX	3.40	0.50*	3.05	0.45	24.15*	20.20*	18.15*	14.20*		1.03			7°	16°

JEDEC Registration MO-112, Variation CB-1, Issue B, Sept. 1995.
 * This dimension is not specified in the original JEDEC drawing. The value listed is for reference only.

Drawings not to scale.
Supertex Doc. #: DSPD-80PQFP, Version B101708.

(The package drawing(s) in this data sheet may not reflect the most current specifications. For the latest package outline information go to <http://www.supertex.com/packaging.html>.)

Supertex inc. does not recommend the use of its products in life support applications, and will not knowingly sell them for use in such applications unless it receives an adequate "product liability indemnification insurance agreement." Supertex inc. does not assume responsibility for use of devices described, and limits its liability to the replacement of the devices determined defective due to workmanship. No responsibility is assumed for possible omissions and inaccuracies. Circuitry and specifications are subject to change without notice. For the latest product specifications refer to the Supertex inc. website: <http://www.supertex.com>.