

32-Channel Serial to Parallel Converter With High Voltage Push-Pull Outputs

Features

- ▶ Processed with HVCMOS® technology
- ▶ Low power level shifting
- ▶ Source/sink current minimum 20mA
- ▶ Shift register speed 8.0MHz
- ▶ Latched data outputs
- ▶ CMOS compatible inputs
- ▶ Forward and reverse shifting options
- ▶ Diode to VPP allows efficient power recovery

General Description

The HV5308B is a low voltage serial to high voltage parallel converter with push-pull outputs. This device has been designed for use as a driver for AC-electroluminescent displays. It can also be used in any application requiring multiple output high voltage current sourcing and sinking capabilities, such as driving plasma panels, vacuum fluorescent, or large matrix LCD displays.

The HV5308B consists of a 32-bit shift register, 32 latches, and control logic to enable outputs. Q1 is connected to the first stage of the shift register through the Output Enable logic. Data is shifted through the shift register on the low to high transition of the clock. When viewed from the top of the package, the HV5308B shifts in the clockwise direction. A data output buffer is provided for cascading devices. This output reflects the current status of the last bit of the shift register (32). Operation of the shift register is not affected by the \overline{LE} (latch enable) or the OE (output enable) inputs. Transfer of data from the shift register to the latch occurs when the \overline{LE} input is high. The data in the latch is retained when \overline{LE} is low.

Typical Application Circuit

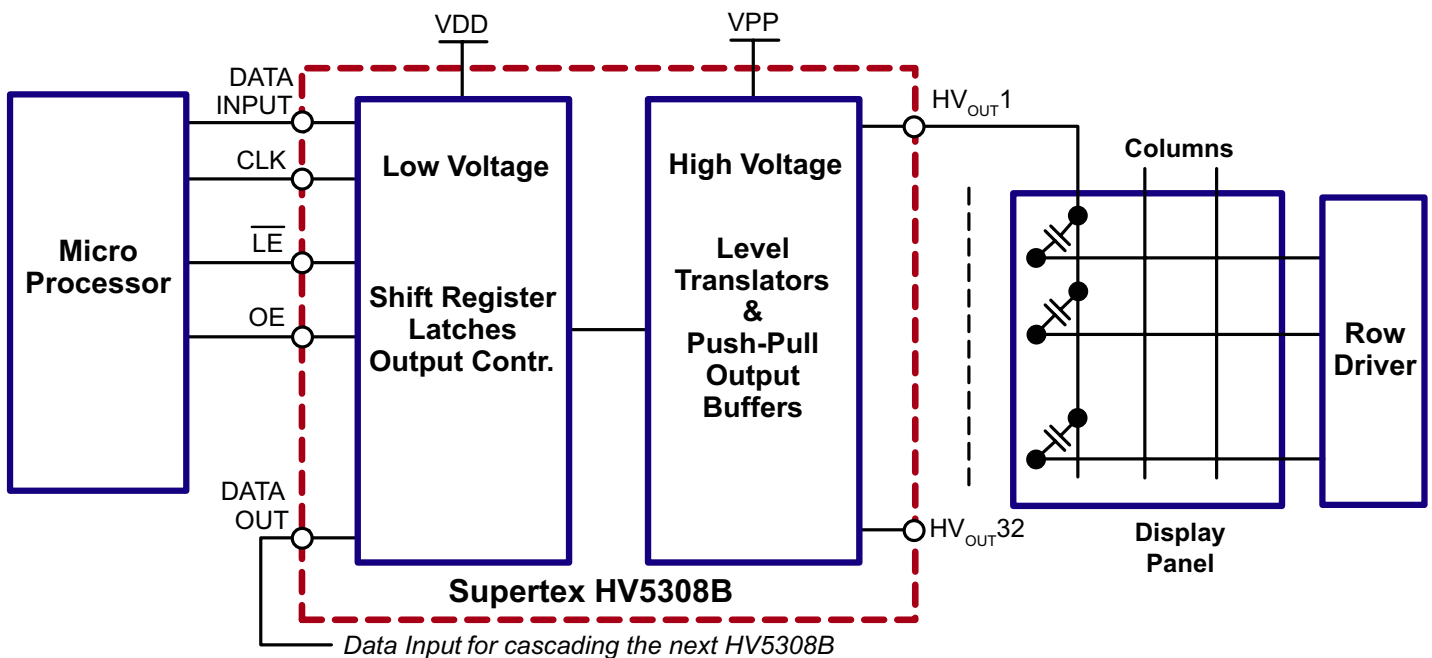

Ordering Information

Device	Package Options		
	44-Lead Quad Cerpac .650x.650in body .190in height (max) .050in pitch	44-Lead PQFP 10.00x10.00mm body 2.35mm height (max) 0.80mm pitch	44-Lead PLCC .653x.653in body .180in height (max) .050in pitch
HV5308B	HV5308DJ-B*	HV5308PG-B-G	HV5308PJ-B-G



-G indicates package is RoHS compliant ('Green').

* Hi-Rel process flow available.

Absolute Maximum Ratings

Parameter	Value
Supply voltage, V_{DD}	-0.5V to +16V
Supply voltage, V_{PP}	-0.5V to +90V
Logic input levels	-0.5V to $V_{DD} + 0.5V$
Ground current ¹	1.5A
Continuous total power dissipation ²	
Plastic	1200mW
Ceramic	1500mW
Operating temperature range	
Plastic	-40°C to +85°C
Ceramic	-55°C to +125°C
Storage temperature range	-65°C to +150°C

Absolute Maximum Ratings are those values beyond which damage to the device may occur. Functional operation under these conditions is not implied. Continuous operation of the device at the absolute rating level may affect device reliability. All voltages are referenced to device ground.

Notes:

- Duty cycle is limited by the total power dissipated in the package.
- For operation above 25°C ambient derate linearly to maximum operating temperature at 20mW/°C for plastic and at 15mW/°C for ceramic.

Pin Configurations

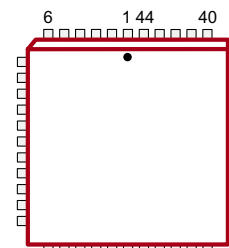

44-Lead Quad Cerpac (DJ)
(top view)

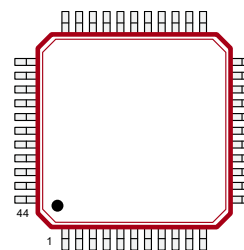

44-Lead PQFP (PG)
(top view)

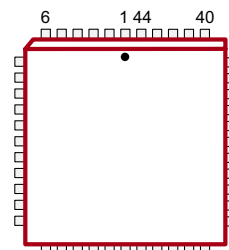

44-Lead PLCC (PJ)
(top view)

Product Marking

Top Marking



YY = Year Sealed
WW = Week Sealed
L = Lot Number
C = Country of Origin*
A = Assembler ID*

Bottom Marking

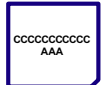

*May be part of top marking

44-Lead Quad Cerpac
(DJ)

Top Marking



YY = Year Sealed
WW = Week Sealed
L = Lot Number
C = Country of Origin*
A = Assembler ID*
— = "Green" Packaging
*May be part of top marking

Bottom Marking

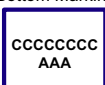

44-Lead PQFP
(PG)

Top Marking



YY = Year Sealed
WW = Week Sealed
L = Lot Number
A = Assembler ID
C = Country of Origin*
— = "Green" Packaging
*May be part of top marking

Bottom Marking



44-Lead PLCC
(PJ)

Packages may or may not include the following marks: Si or

Recommended Operating Conditions (over -40°C to 85°C for plastic and -55°C to 125°C for ceramic)

Sym	Parameter	Min	Max	Units
V_{DD}	Logic voltage supply	10.8	13.2	V
V_{PP}	High voltage supply	8.0	80	V
V_{IH}	Input high voltage	$V_{DD} - 2.0$	V_{DD}	V
V_{IL}	Input low voltage	0	2.0	V
f_{CLK}	Clock frequency	0	8.0	MHz

Power-Up Sequence

Power-up sequence should be the following:

1. Connect ground
2. Apply V_{DD}
3. Set all inputs (Data, CLK, \overline{LE} , etc.) to a known state
4. Apply V_{PP}
5. The V_{PP} should not fall below V_{DD} or float during operation.

Power-down sequence should be the reverse of the above.

Electrical Characteristics ($V_{PP} = 60\text{V}$, $V_{DD} = 12\text{V}$, $T_A = 25^{\circ}\text{C}$)**DC Characteristics**

Sym	Parameter	Min	Max	Units	Conditions
I_{PP}	V_{PP} supply current	-	0.5	mA	HV _{OUTPUTS} high to low
I_{DDQ}	I_{DD} supply current (quiescent)	-	100	μA	All inputs = V_{DD} or GND
I_{DD}	I_{DD} supply current (operating)	-	15	mA	$V_{DD} = V_{DD}$ max, $f_{CLK} = 8.0\text{MHz}$
V_{OH} (data)	Shift register output voltage	10.5	-	V	$I_O = -100\mu\text{A}$
V_{OL} (data)	Shift register output voltage	-	1.0	V	$I_O = 100\mu\text{A}$
I_{IH}	Current leakage, any input	-	1.0	μA	$V_{IN} = V_{DD}$
I_{IL}	Current leakage, any input	-	-1.0	μA	$V_{IN} = 0$
V_{OC}	HV output clamp diode voltage	-	-1.5	V	$I_{OL} = -100\text{mA}$
V_{OH}	HV output when sourcing	52	-	V	$I_{OH} = -20\text{mA}$, -40 to 85°C
V_{OL}	HV output when sinking	-	8.0	V	$I_{OL} = 20\text{mA}$, -40 to 85°C
V_{OH}	HV output when sourcing	52	-	V	$I_{OH} = -15\text{mA}$, -55 to 125°C
V_{OL}	HV output when sinking	-	8.0	V	$I_{OL} = 15\text{mA}$, -55 to 125°C

AC Characteristics

Sym	Parameter	Min	Max	Units	Conditions
f_{CLK}	Clock frequency	-	8.0	MHz	---
t_{WL} or t_{WH}	Clock width, HIGH or LOW	62	-	ns	---
t_{SU}	Setup time before CLK rises	25	-	ns	---
t_H	Hold time after CLK rises	10	-	ns	---
t_{DLH} (Data)	Data output delay after L to H CLK	-	110	ns	$C_L = 15pF$
t_{DHL} (Data)	Data output delay after H to L CLK	-	110	ns	$C_L = 15pF$
t_{DLE}	\overline{LE} delay after L to H CLK	50	-	ns	---
t_{WLE}	Width of \overline{LE} pulse	50	-	ns	---
t_{SLE}	\overline{LE} setup time before L to H CLK	50	-	ns	---
t_{ON}	Delay from \overline{LE} to HV_{OUT} L to H	-	500	ns	---
t_{OFF}	Delay from \overline{LE} to HV_{OUT} H to L	-	500	ns	---

Switching Waveforms

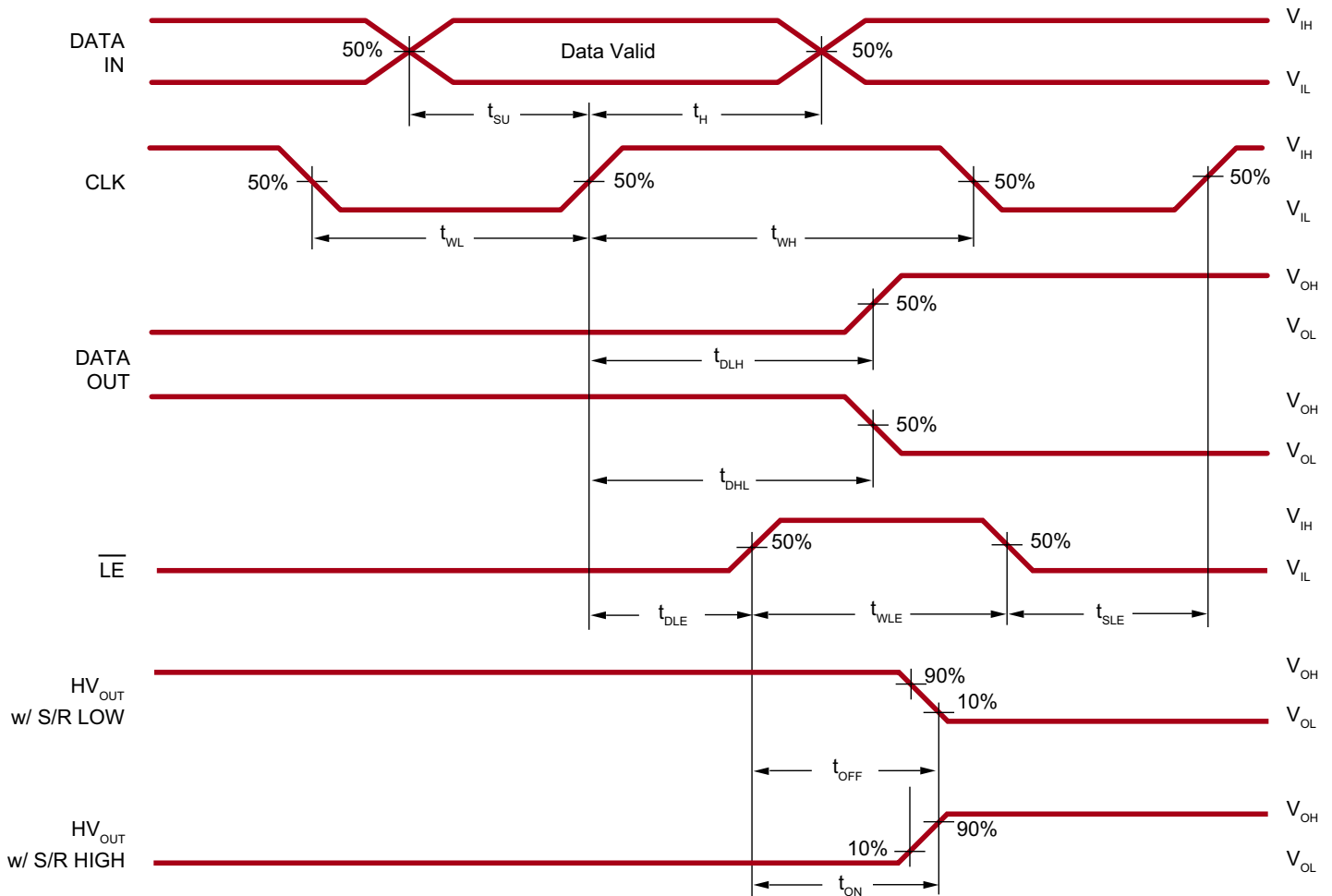

Input and Output Equivalent Circuits

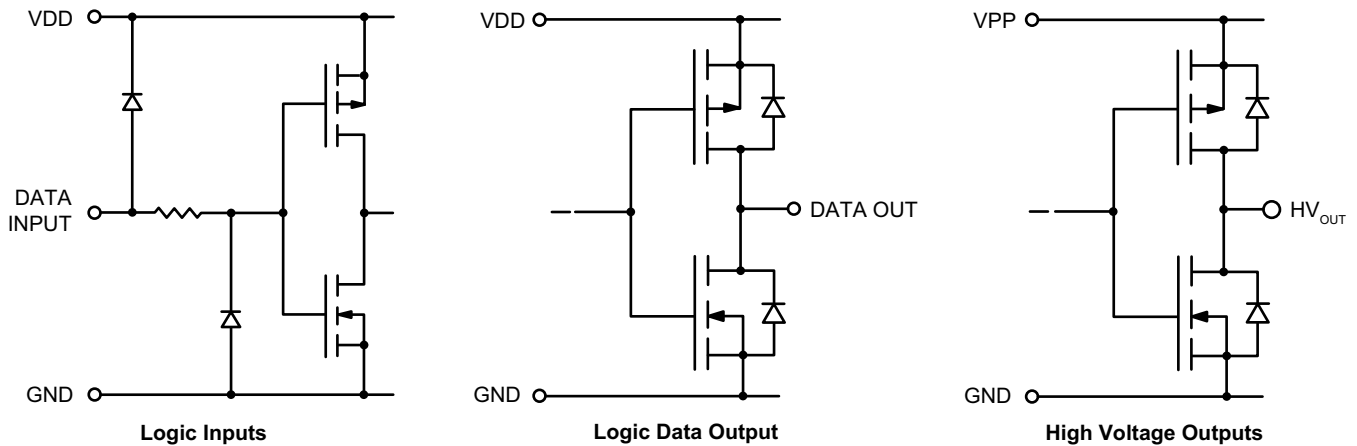

Functional Block Diagram

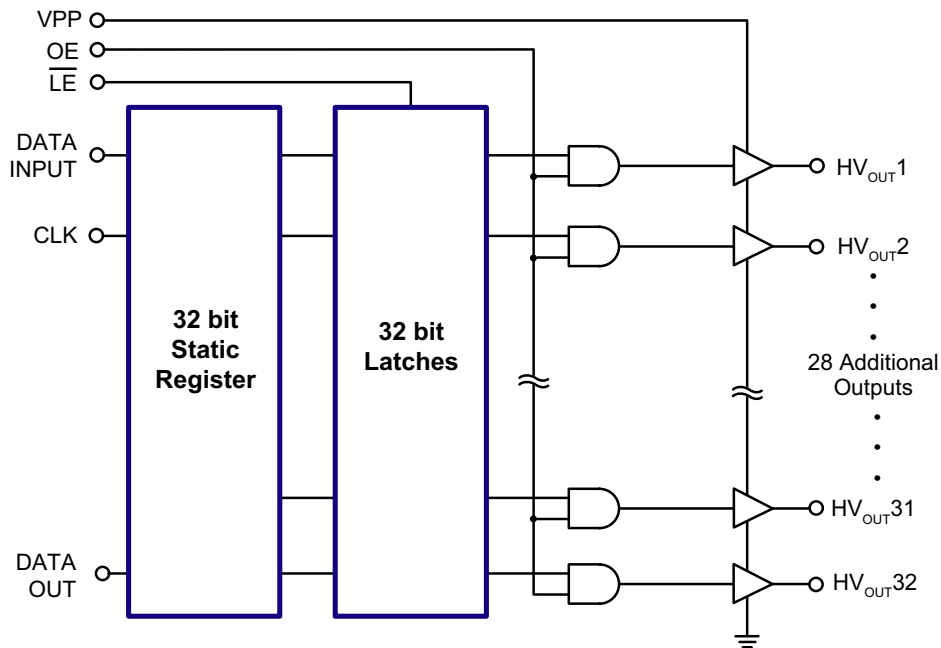

Function Tables

DATA IN	CLK*	DATA OUT
H		H
L		L
X	No	No change

Note:
* = LOW - to - HIGH transition

H = High
L = Low
X = Don't Care

DATA IN	LE	OE	HV OUT
X	X	L	All HV_OUT = LOW
X	L	H	Previous latched data
H	H	H	H
L	H	H	L

44-Lead PQFP Pin Assignment (PG)

Pin #	Function	Description
1	HV _{OUT} 22	High voltage outputs. High voltage push-pull outputs, which, depending on controlling low voltage data, can drive loads either to GND, or to V _{PP} rail levels.
2	HV _{OUT} 21	
3	HV _{OUT} 20	
4	HV _{OUT} 19	
5	HV _{OUT} 18	
6	HV _{OUT} 17	
7	HV _{OUT} 16	
8	HV _{OUT} 15	
9	HV _{OUT} 14	
10	HV _{OUT} 13	
11	HV _{OUT} 12	
12	HV _{OUT} 11	
13	HV _{OUT} 10	
14	HV _{OUT} 9	
15	HV _{OUT} 8	
16	HV _{OUT} 7	
17	HV _{OUT} 6	
18	HV _{OUT} 5	
19	HV _{OUT} 4	
20	HV _{OUT} 3	
21	HV _{OUT} 2	
22	HV _{OUT} 1	
23	DATA OUT	Serial data output. Data output for cascading to the data input of the next device.
24	N/C	No connect.
25		
26		
27	CLK	Data shift register clock Input are shifted into the shift register on the positive edge of the clock.
28	GND	Logic and high voltage ground
29	VPP	High voltage power rail.
30	VDD	Low voltage logic power rail.

44-Lead PQFP Pin Assignment (PG)

Pin #	Function	Description
31	$\overline{\text{LE}}$	Latch enable input. When $\overline{\text{LE}}$ is HIGH, shift register data is transferred into a data latch. When $\overline{\text{LE}}$ is LOW, data is latched, and new data can be clocked into the shift register.
32	DATA IN	Serial data input. Data needs to be present before each rising edge of the clock.
33	OE	Output enable input. When OE is LOW, all HV outputs are forced into a LOW state, regardless of data in each channel. When OE is HIGH, all HV outputs reflect data latched.
34	N/C	No connect.
35	HV _{OUT} 32	High voltage outputs. High voltage push-pull outputs, which, depending on controlling low voltage data, can drive loads either to GND, or to V _{PP} rail levels.
36	HV _{OUT} 31	
37	HV _{OUT} 30	
38	HV _{OUT} 29	
39	HV _{OUT} 28	
40	HV _{OUT} 27	
41	HV _{OUT} 26	
42	HV _{OUT} 25	
43	HV _{OUT} 24	
44	HV _{OUT} 23	

44-Lead Quad Cerpac/PLCC Pin Assignment (DJ/PJ)

Pin #	Function	Description
1	HV _{OUT} 17	High voltage outputs. High voltage push-pull outputs, which, depending on controlling low voltage data, can drive loads either to GND, or to V _{PP} rail levels.
2	HV _{OUT} 16	
3	HV _{OUT} 15	
4	HV _{OUT} 14	
5	HV _{OUT} 13	
6	HV _{OUT} 12	
7	HV _{OUT} 11	
8	HV _{OUT} 10	
9	HV _{OUT} 9	
10	HV _{OUT} 8	
11	HV _{OUT} 7	
12	HV _{OUT} 6	
13	HV _{OUT} 5	
14	HV _{OUT} 4	
15	HV _{OUT} 3	
16	HV _{OUT} 2	
17	HV _{OUT} 1	
18	DATA OUT	Serial data output. Data output for cascading to the data input of the next device.
19	N/C	No connect.
20		
21		
22	CLK	Data shift register clock Input are shifted into the shift register on the positive edge of the clock.
23	GND	Logic and high voltage ground
24	VPP	High voltage power rail.
25	VDD	Low voltage logic power rail.
26	$\overline{\text{LE}}$	Latch enable input. When $\overline{\text{LE}}$ is HIGH, shift register data is transferred into a data latch. When $\overline{\text{LE}}$ is LOW, data is latched, and new data can be clocked into the shift register.
27	DATA IN	Serial data input. Data needs to be present before each rising edge of the clock.

44-Lead Quad Cerpac/PLCC Pin Assignment (DJ/PJ)

Pin #	Function	Description
28	OE	Output enable input. When OE is LOW, all HV outputs are forced into a LOW state, regardless of data in each channel. When OE is HIGH, all HV outputs reflect data latched.
29	N/C	No connect.
30	HV _{OUT} 32	High voltage outputs. High voltage push-pull outputs, which, depending on controlling low voltage data, can drive loads either to GND, or to V _{PP} rail levels.
31	HV _{OUT} 31	
32	HV _{OUT} 30	
33	HV _{OUT} 29	
34	HV _{OUT} 28	
35	HV _{OUT} 27	
36	HV _{OUT} 26	
37	HV _{OUT} 25	
38	HV _{OUT} 24	
39	HV _{OUT} 23	
40	HV _{OUT} 22	
41	HV _{OUT} 21	
42	HV _{OUT} 20	
43	HV _{OUT} 19	
44	HV _{OUT} 18	

44-Lead Quad Cerpac Package Outline (DJ)

.650x.650in body, .190in height (max), .050in pitch

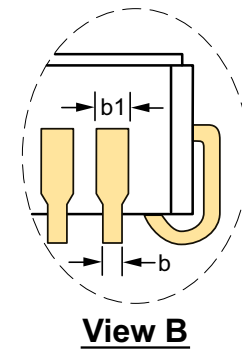
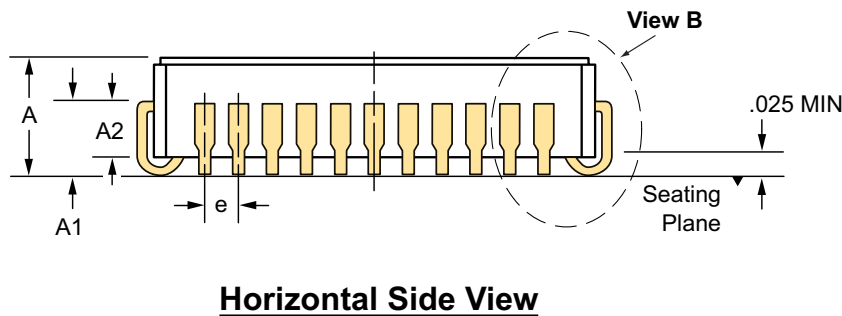
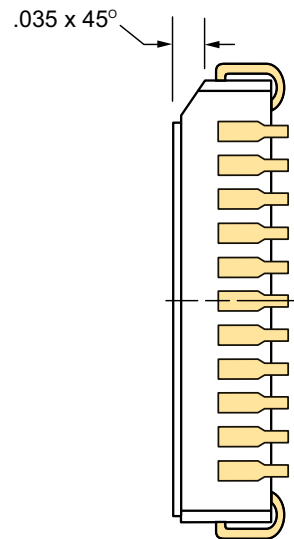
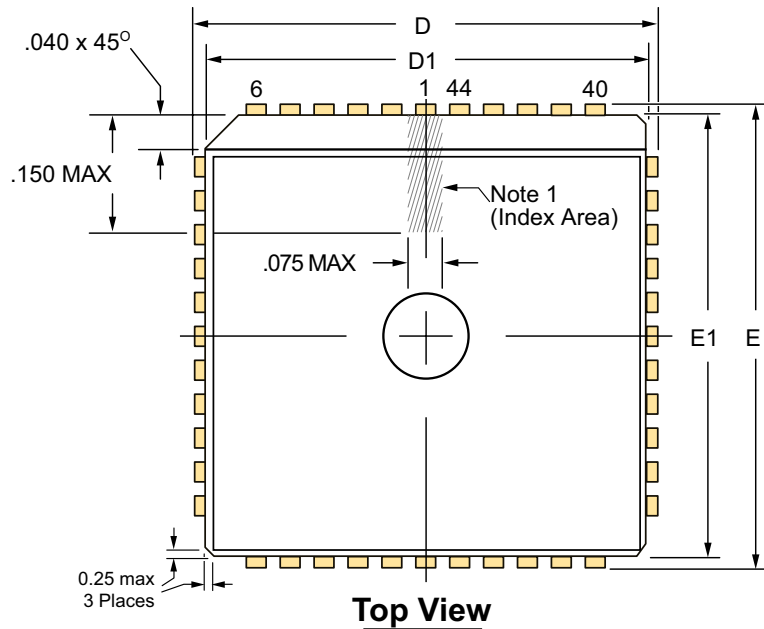

Note:
 1. A Pin 1 identifier must be located in the index area indicated. The Pin 1 identifier can be: a molded mark/identifier; an embedded metal marker; or a printed indicator.

Symbol	A	A1	A2	b	b1	D	D1	E	E1	e	
Dimension (inches)	MIN	.155	.090	.060 REF	.017	.026	.685	.630	.685	.630	.050 BSC
	NOM	.172	.100		.019	.029	.690	.650	.690	.650	
	MAX	.190	.120		.021	.032	.695	.665	.695	.665	

JEDEC Registration MO-087, Variation AB, Issue B, August, 1991.

Drawings not to scale.

Supertex Doc. #: DSPD-44CERPACDJ, Version D090808.

44-Lead PQFP Package Outline (PG)

10.00x10.00mm body, 2.35mm height (max), 0.80mm pitch

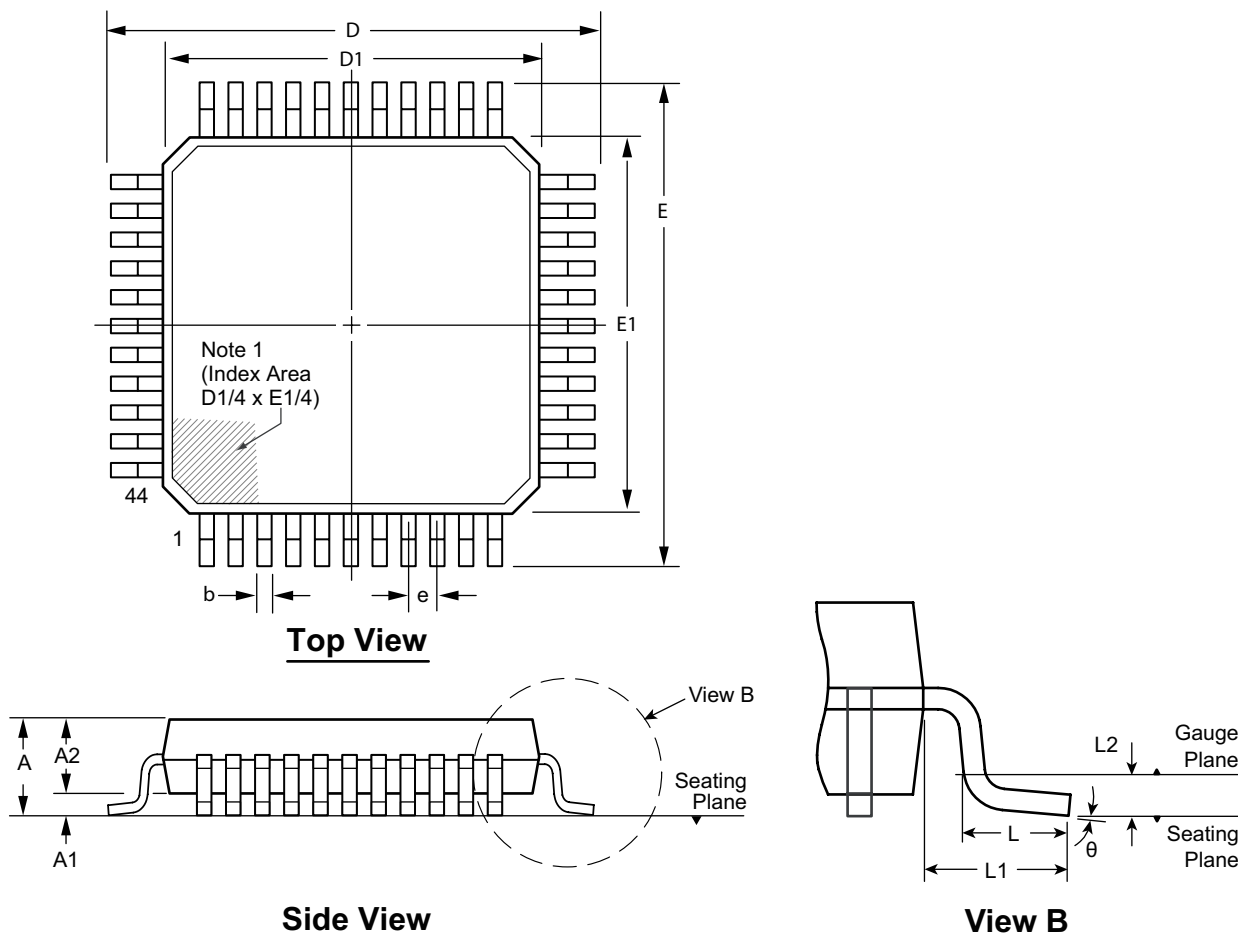

Note:
 1. A Pin 1 identifier must be located in the index area indicated. The Pin 1 identifier can be: a molded mark/identifier; an embedded metal marker; or a printed indicator.

Symbol	A	A1	A2	b	D	D1	E	E1	e	L	L1	L2	θ	
Dimension (mm)	MIN	1.95*	0.00	1.95	0.30	13.65*	9.80*	13.65*	9.80*	0.80 BSC	1.95 REF	0.25 BSC	0°	
	NOM	-	-	2.00	-	13.90	10.00	13.90	10.00				0.73	3.5°
	MAX	2.35	0.25	2.10	0.45	14.15*	10.20*	14.15*	10.20*				0.88	7°

JEDEC Registration MO-112, Variation AA-2, Issue B, Sep. 1995.

* This dimension is not specified in the JEDEC drawing.

Drawings not to scale.

Supertex Doc. #: DSPD-44PQFP, Version C041309.

44-Lead PLCC Package Outline (PJ)

.653x.653in body, .180in height (max), .050in pitch

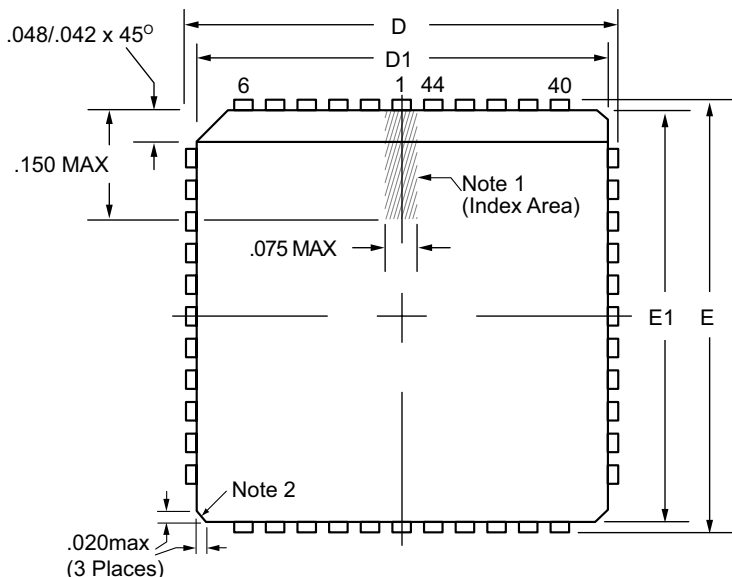

Top View

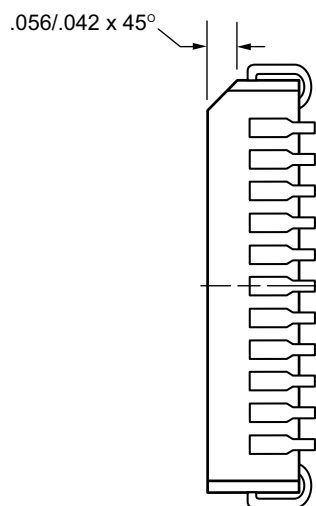

Vertical Side View

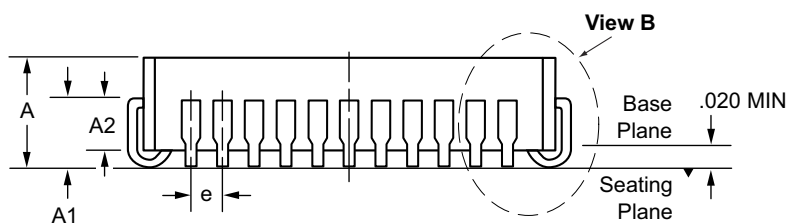

Horizontal Side View

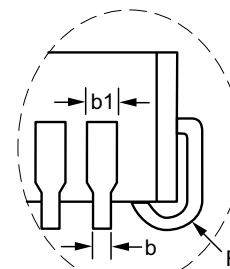

View B

Notes:

1. A Pin 1 identifier must be located in the index area indicated. The Pin 1 identifier can be: a molded mark/identifier; an embedded metal marker; or a printed indicator.
2. Actual shape of this feature may vary.

Symbol	A	A1	A2	b	b1	D	D1	E	E1	e	R	
Dimension (inches)	MIN	.165	.090	.062	.013	.026	.685	.650	.685	.650	.050 BSC	.025
	NOM	.172	.105	-	-	-	.690	.653	.690	.653		.035
	MAX	.180	.120	.083	.021	.036†	.695	.656	.695	.656		.045

JEDEC Registration MS-018, Variation AC, Issue A, June, 1993.

† This dimension differs from the JEDEC drawing.

Drawings not to scale.

Supertex Doc. #: DSPD-44PLCCPJ, Version F031111.

(The package drawing(s) in this data sheet may not reflect the most current specifications. For the latest package outline information go to <http://www.supertex.com/packaging.html>.)

Supertex inc. does not recommend the use of its products in life support applications, and will not knowingly sell them for use in such applications unless it receives an adequate "product liability indemnification insurance agreement." **Supertex inc.** does not assume responsibility for use of devices described, and limits its liability to the replacement of the devices determined defective due to workmanship. No responsibility is assumed for possible omissions and inaccuracies. Circuitry and specifications are subject to change without notice. For the latest product specifications refer to the **Supertex inc.** (website: <http://www.supertex.com>)