

8-Channel Serial to Parallel Converter with High Voltage Push-Pull Outputs

Features

- ▶ HVCMOS® technology
- ▶ Operating output voltage of 250V
- ▶ Low power level shifting from 5.0 to 250V
- ▶ Shift register speed 8.0MHz @ $V_{DD} = 5.0V$
- ▶ 8 latch data outputs
- ▶ Output blanking
- ▶ Programmable POL latch
- ▶ CMOS compatible inputs

Applications

- ▶ Piezoelectric transducer driver
- ▶ Braille driver
- ▶ Weaving applications
- ▶ Printer drivers
- ▶ MEMs
- ▶ Displays

General Description

The HV514 is a low voltage serial to high voltage parallel converter with 8 high voltage push-pull outputs. This device has been designed to drive small capacitive loads such as piezoelectric transducers. It can also be used in any application requiring multiple high voltage outputs, medium current sourcing and sinking capabilities.

The device consists of an 8-bit shift register, dual 8-bit latches, and control logic to latch data, and control blanking of the outputs. Data is shifted through the shift register on the rising transition of the clock. A data output buffer is provided for cascading devices. Operation of the shift register is not affected by the \overline{LE} , SEL, or the \overline{BL} inputs. Transfer of data from the shift register to the latch occurs when the \overline{LE} is high. Shift register data is shifted to the 8-bit Data Latch when SEL is high; and shift register data is shifted to the 8-bit Polarity Latch when SEL is low. The data is held in the output latches whenever \overline{LE} is low.

The high voltage output state is primarily dependent on the value in the polarity latch. If \overline{BL} is low, the output condition is the result of a 1 being exclusively-NOR'ed with the polarity latch value. If \overline{BL} is high, the output condition is the result of the data latch being exclusively-NOR'ed with the polarity latch.

All outputs with have a break-before-make circuitry to reduce cross-over current during output state changes.

Note:
1. \overline{LE} , SEL, and \overline{BL} have internal 20kΩ pull-up resistors.

Block Diagram

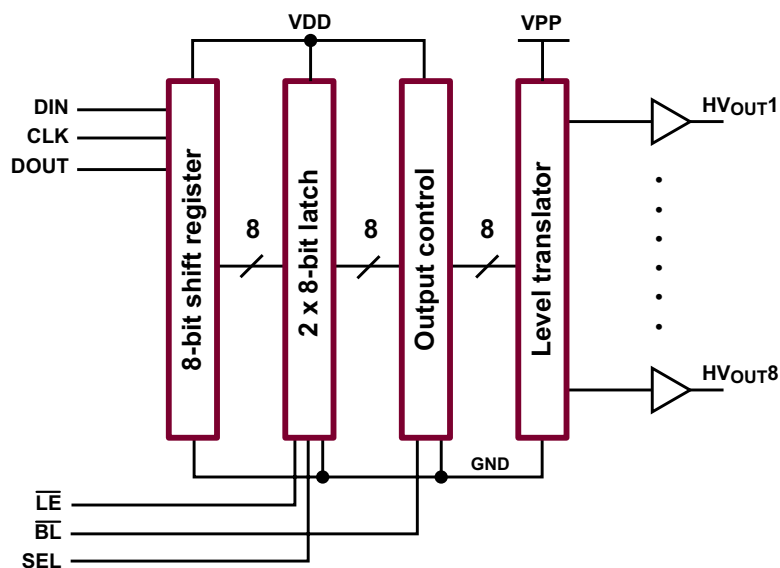

Ordering Information

Device	Package Option
	20-Lead SOW 12.80x7.50mm body 2.65mm height (max) 1.27 pitch
HV514	HV514WG-G

-G indicates package is RoHS compliant ("Green")



Pin Configuration

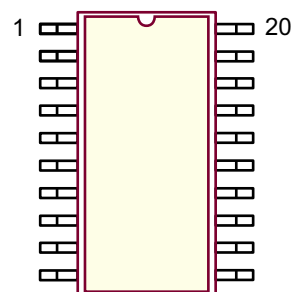

20-Lead SOW (WG)
(top view)

Absolute Maximum Ratings

Parameter	Value
Supply voltage, V_{DD}	-0.5V to 6.0V
Supply voltage, V_{PP}	275V
Logic input levels	-0.5V to $V_{DD} + 0.5V$
Ground current	0.3A
High voltage supply current	0.25A
Continuous total power dissipation	750mW
Operating junction temperature	-40°C to +85°C
Storage temperature range	-65°C to +150°C

Absolute Maximum Ratings are those values beyond which damage to the device may occur. Functional operation under these conditions is not implied. Continuous operation of the device at the absolute rating level may affect device reliability. All voltages are referenced to device ground.

Product Marking

Top Marking



YY = Year Sealed
 WW = Week Sealed
 L = Lot Number
 C = Country of Origin
 A = Assembler ID*

Bottom Marking

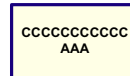

— = "Green" Packaging
 *May be part of top marking

20-Lead SOW (WG)

Typical Operating Conditions

Sym	Parameter	Min	Typ	Max	Units	Conditions
V_{DD}	Logic supply voltage	4.5	5.0	5.5	V	---
V_{PP}	High voltage supply	50	-	250	V	Note 1
V_{IH}	High-level input voltage	$V_{DD} - 0.9$	-	V_{DD}	V	---
V_{IL}	Low-level input voltage	0	-	0.9	V	---
T_J	Operating junction temperature	-40	-	+85	°C	---

Notes:

- Below minimum V_{PP} the output may not switch.
- Power-up sequence should be the following:
 - Connect ground
 - Apply V_{DD}
 - Set all inputs (Data, CLK, Enable, etc.) to a known state
 - Apply V_{PP}

Power-down sequence should be the reverse of the above

DC Electrical Characteristics (Over typical operating conditions unless otherwise specified, $T_J = 25^\circ\text{C}$)

Sym	Parameter	Min	Typ	Max	Units	Conditions	
I_{DD}	V_{DD} supply current	-	-	4.0	mA	$f_{CLK} = 8.0\text{MHz}$, $\overline{LE} = \text{Low}$	
I_{DDQ}	Quiescent V_{DD} supply current	-	-	0.1	mA	All $V_{IN} = V_{DD}$	
		-	-	2.0		All $V_{IN} = 0\text{V}$	
I_{PP}	V_{PP} supply current	-	-	100	μA	$V_{PP} = 250\text{V}$, $f_{OUT} = 300\text{Hz}$, no load	
I_{PPQ}	Quiescent V_{PP} supply current	-	-	100	μA	$V_{PP} = 240\text{V}$, outputs are static	
I_{IH}	High-level logic input current	-	-	10	μA	$V_{IH} = V_{DD}$	
I_{IL}	Low-level logic input current	-	-	-10	μA	$V_{IL} = 0\text{V}$	
		-	-	-350		$V_{IL} = 0\text{V}$ for inputs w/pull-up resistors	
I_{DPP}	Dynamic I_{PP}	-	-	0.1	mA	$f_{OUT} = 100\text{kHz}$, no load	
V_{OH}	High level output	HV _{OUT}	140	-	-	V	$V_{PP} = 200\text{V}$, $I_{HVOUT} = -20\text{mA}$
		Data out	$V_{DD} - 1.0\text{V}$	-	-		$I_{DOUT} = -0.1\text{mA}$
V_{OL}	Low level output	HV _{OUT}	-	-	60	V	$V_{DD} = 4.5\text{V}$, $I_{HVOUT} = 20\text{mA}$
		Data out	-	-	1.0		$I_{DOUT} = 0.1\text{mA}$

AC Electrical Characteristics (Over typical operating conditions unless otherwise specified, $T_J = 25^\circ\text{C}$)

Sym	Parameter	Min	Typ	Max	Units	Conditions
f_{CLK}	Clock frequency	0	-	8.0	MHz	---
f_{OUT}	Output switching frequency (SOA limited)	-	300	-	Hz	$C_L = 50\text{nF}$, $V_{PP} = 200\text{V}$
t_W	Clock width high and low	62	-	-	ns	---
t_{SU}	Data setup time before clock rises	15	-	-	ns	---
t_H	Data hold time after clock rises	30	-	-	ns	---
t_{WLE}	Width of latch enable pulse	80	-	-	ns	---
t_{DLE}	\overline{LE} delay time after rising edge of clock	35	-	-	ns	---
t_{SLE}	\overline{LE} setup time before rising edge of clock	40	-	-	ns	---
t_{OR}, t_{OF}	HV _{OUT} rise/fall time	-	-	1000	μs	$C_L = 100\text{nF}$, $V_{PP} = 200\text{V}$
$t_{dON/OFF}$	Delay time for output to start rise/fall	-	-	500	ns	---
t_{DHL}	Delay time clock to D _{OUT} high to low	-	-	110	ns	$C_L = 15\text{pF}$
t_{DLH}	Delay time clock to D _{OUT} low to high	-	-	110	ns	$C_L = 15\text{pF}$
t_R, t_F	All logic inputs	-	-	5.0	ns	---

Input and Output Equivalent Circuits

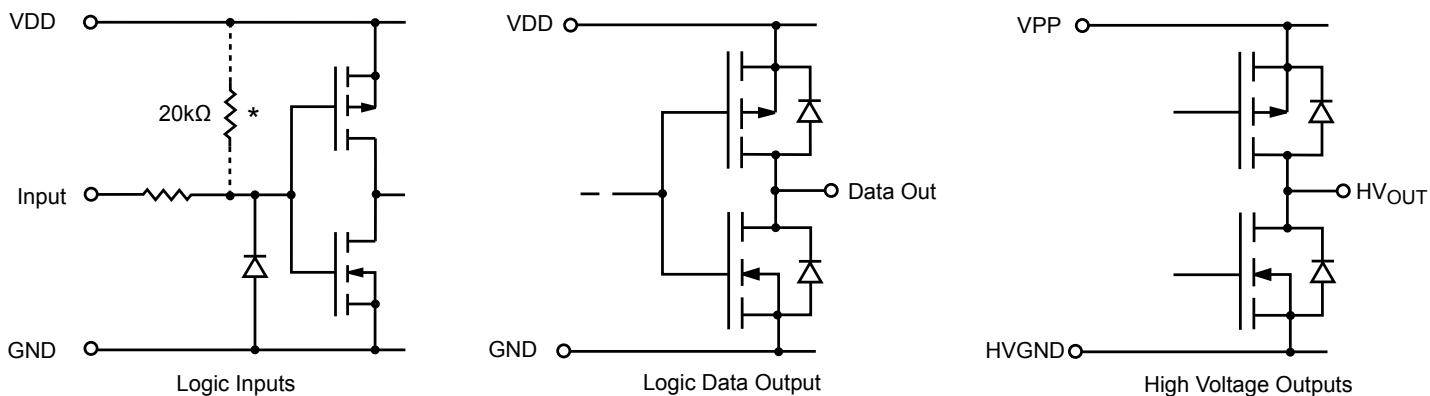

Notes:
 There is an internal output resistor for the high voltage output pin for SOA protection.
 * \overline{LE} , SEL , SL

Switching Waveforms

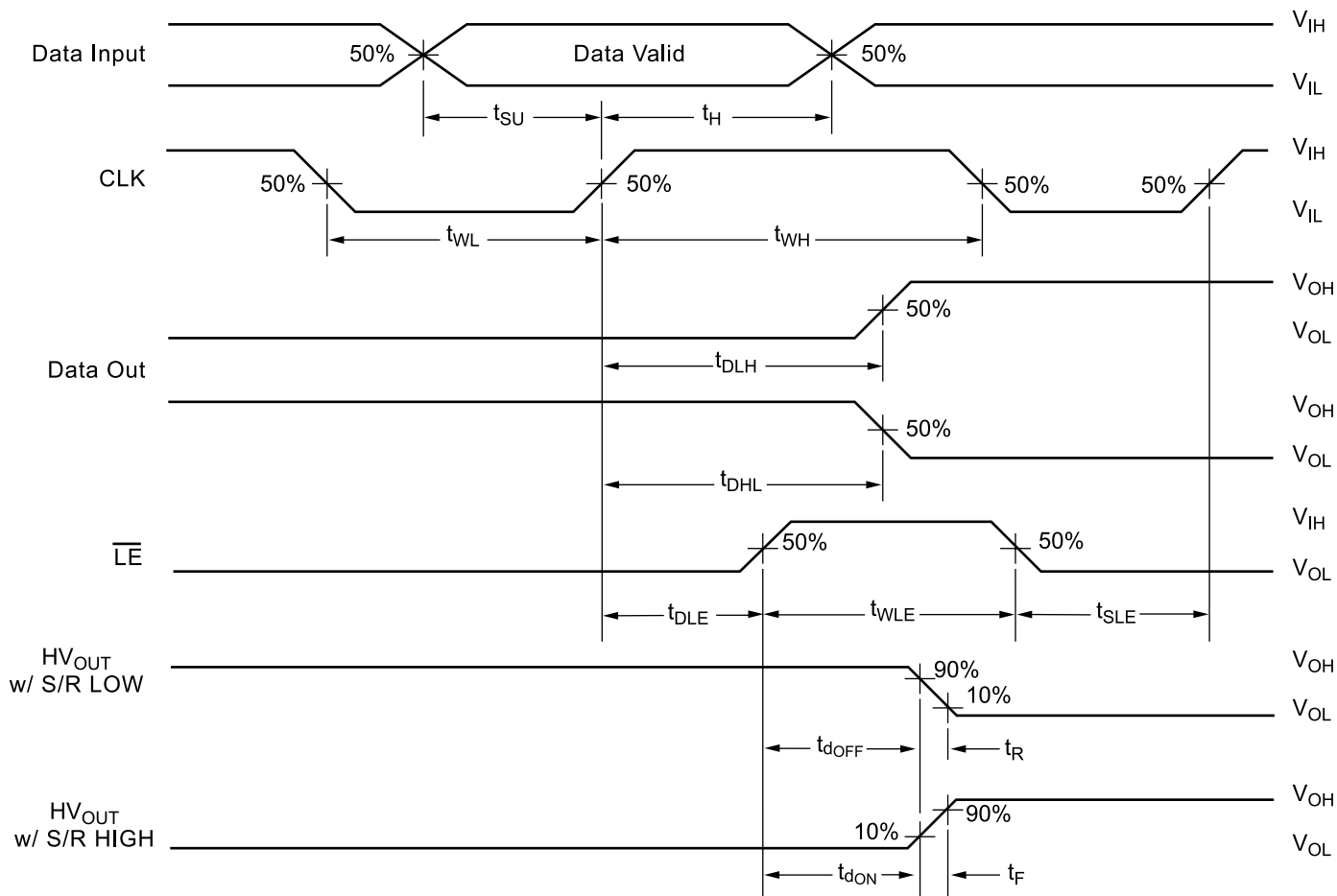

Note:
 \overline{LE} , SEL , and \overline{BL} have internal 20kΩ pull-up resistors.

Function Table

Function	Inputs					Outputs			
	Data	CLK	\overline{LE}	SEL	\overline{BL}	Shift Reg 1 2...8	Latch	HV Output Action 1 2...8	Data Out
Load S/R	H OR L	-	-	-	-	H or L •...•	• •...•	• •...•	•
Transfer S/R to latch	X	X	H	H	-	H or L •...•	To data	• •...•	•
Invert mode	X	X	H	L	-	H or L •...•	To polarity	• •...•	•
Hold latch data	X	X	L	-	-	• •...•	• •...•	• •...•	•
Blank output	X	X	X	X	L	• •...•	• •...•	1 (XNOR) POL	•
Active output	X	X	X	X	H	• •...•	• •...•	Data (XNOR) POL	•

Notes:

H = high level, L = low level, X = irrelevant, ↑ = low-to-high transition

• = dependent on previous stage's state before the last CLK or last \overline{LE} high.

Blanking Function Table

\overline{BL}	Latched Information		HV Output
	Data	\overline{POL}	
L	X	L	L
L	X	H	H
H	L	L	L
H	H	L	H
H	L	H	L
H	H	H	H

Note:

H = high level, L = low level

Functional Block Diagram

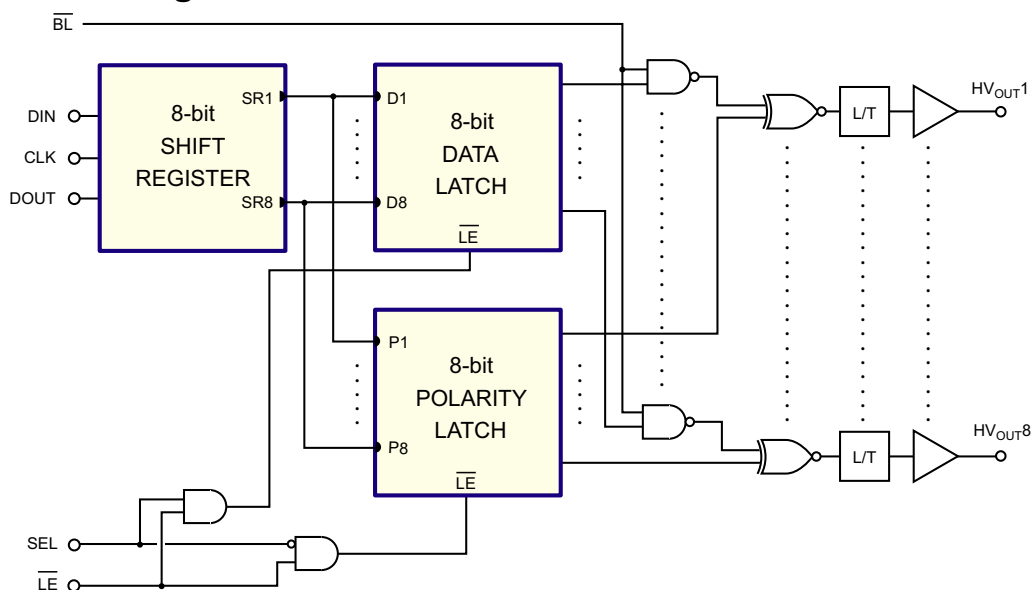

Note:
 \overline{BL} , \overline{LE} , and SEL have internal 20k Ω pull-up resistors.

Pin Description

Pin #	Function	Description
1	CLK	Clock pin, shift registers shifts data on rising edge of input clock.
2	\overline{LE}	Latch enable bar input logic.
3	DIN	Data input.
4	LGND	Low voltage ground.
5	HVGND	High voltage ground.
6		
7	HV _{OUT1}	High voltage push-pull output.
8	HV _{OUT2}	High voltage push-pull output.
9	HV _{OUT3}	High voltage push-pull output.
10	HV _{OUT4}	High voltage push-pull output.
11	HV _{OUT5}	High voltage push-pull output.
12	HV _{OUT6}	High voltage push-pull output.
13	HV _{OUT7}	High voltage push-pull output.
14	HV _{OUT8}	High voltage push-pull output.
15	VPP	High voltage power supply pin.
16		
17	VDD	Logic supply voltage.
18	DOUT	Data output.
19	\overline{BL}	Blanking pin, logic input LOW sets all HV _{OUTS} low. See truth table.
20	SEL	Data select.

20-Lead SOW (Wide Body) Package Outline (WG)

12.80x7.50mm body, 2.65mm height (max), 1.27mm pitch

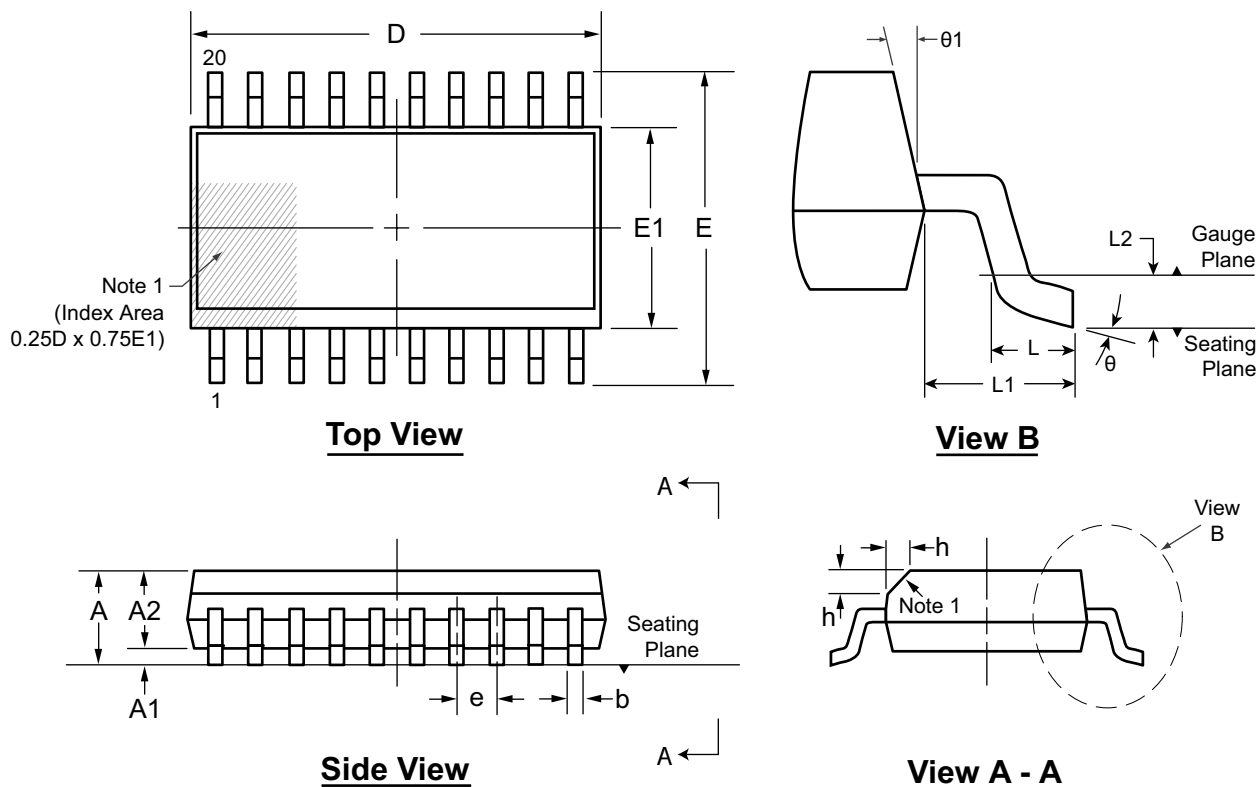

Note:
 1. This chamfer feature is optional. If it is not present, then a Pin 1 identifier must be located in the index area indicated. The Pin 1 Identifier can be: a molded mark/identifier; an embedded metal marker; or a printed indicator.

Symbol		A	A1	A2	b	D	E	E1	e	h	L	L1	L2	θ	θ1
Dimension (mm)	MIN	2.15*	0.10	2.05	0.31	12.60*	9.97*	7.40*	1.27 BSC	0.25	0.40	1.40 REF	0.25 BSC	0°	5°
	NOM	-	-	-	-	12.80	10.30	7.50		-	-			-	-
	MAX	2.65	0.30	2.55*	0.51	13.00*	10.63*	7.60*		0.75	1.27			8°	15°

JEDEC Registration MS-013, Variation AC, Issue E, Sep. 2005.
 * This dimension is not specified in the original JEDEC drawing. The value listed is for reference only.
Drawings are not to scale.
Supertex Doc. #: DSPD-20SOWWG, Version C090408.

(The package drawing(s) in this data sheet may not reflect the most current specifications. For the latest package outline information go to <http://www.supertex.com/packaging.html>.)

Supertex inc. does not recommend the use of its products in life support applications, and will not knowingly sell them for use in such applications unless it receives an adequate "product liability indemnification insurance agreement." Supertex inc. does not assume responsibility for use of devices described, and limits its liability to the replacement of the devices determined defective due to workmanship. No responsibility is assumed for possible omissions and inaccuracies. Circuitry and specifications are subject to change without notice. For the latest product specifications refer to the Supertex inc. website: <http://www.supertex.com>.