

8-Channel Serial to Parallel Converter with High Voltage Push-Pull Outputs, POL, Hi-Z, and Short Circuit Detect

Features

- ▶ HVCMOS® technology
- ▶ Operating output voltage of 250V
- ▶ Low power level shifting from 5.0 to 250V
- ▶ Shift register speed 8.0MHz @ $V_{DD} = 5.0V$
- ▶ 8 latch data outputs
- ▶ Output polarity and blanking
- ▶ Output short circuit detect
- ▶ Output high-Z control
- ▶ CMOS compatible inputs

Applications

- ▶ Piezoelectric transducer driver
- ▶ Braille driver
- ▶ Weaving applications
- ▶ Printer drivers
- ▶ MEMs
- ▶ Displays

General Description

The HV513 is a low voltage serial to high voltage parallel converter with 8 high voltage push-pull outputs. This device has been designed to drive small capacitive loads such as piezoelectric transducers. It can also be used in any application requiring multiple high voltage outputs, with medium current source and sink capabilities.

The device consists of an 8-bit shift register, 8 latches, and control logic to perform the polarity select and blanking of the outputs. Data is shifted through the shift register on the low to high transition of the clock. A data output buffer is provided for cascading devices. Operation of the shift register is not affected by the \overline{LE} , \overline{BL} , \overline{POL} , or the $\overline{HI-Z}$ control inputs. Transfer of data from the shift register to the latch occurs when the \overline{LE} is high. The data in the latch is stored when \overline{LE} is low. A high-Z ($\overline{HI-Z}$) pin is provided to set all the outputs in a high-Z state.

All outputs have short circuit protection that detects if the outputs have reached the required output state. If output does not track the required state, then the \overline{SHORT} pin will be low. This output will pulse low during the output transition period under normal operation; see SC Timing Diagram for details.

All outputs will have a break-before-make circuitry to reduce cross-over current during output state changes.

The \overline{POL} , \overline{BL} , \overline{LE} , and $\overline{HI-Z}$ inputs have an internal pull up resistor.

Typical Application Circuit

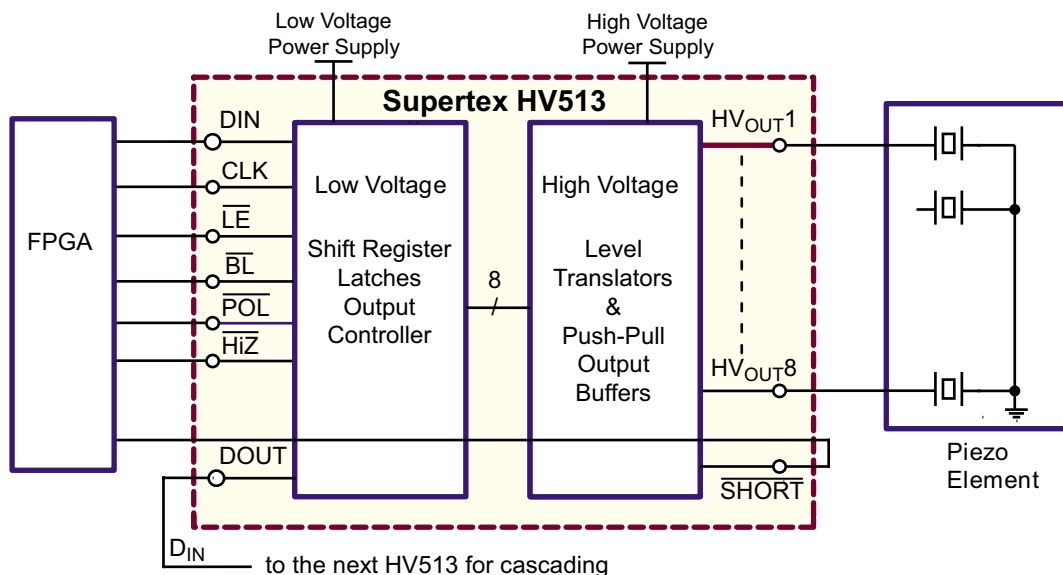

Ordering Information

Device	Package Options	
	32-Lead QFN 6.00x6.00mm body 0.80mm height (max) 0.50 pitch	24-Lead SOW 15.40x7.50mm body 2.65mm height (max) 1.27 pitch
HV513	HV513K7-G	HV513WG-G

-G indicates package is RoHS compliant ('Green')



Pin Configurations

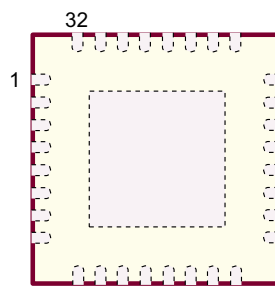

32-Lead QFN (K7)
(top view)

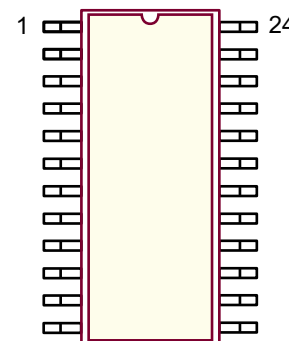

24-Lead SOW (WG)
(top view)

Absolute Maximum Ratings

Parameter	Value
Logic supply, V_{DD}	-0.5V to 6.0V
High voltage supply, V_{PP}	V_{DD} to 275V
Logic input levels	-0.5V to V_{DD} +0.5V
Ground current ¹	0.3A
High voltage supply current ¹	0.25A
Continuous total power dissipation ²	750mW
Operating junction temperature	-40°C to +85°C
Storage temperature range	-65°C to +150°C

Absolute Maximum Ratings are those values beyond which damage to the device may occur. Functional operation under these conditions is not implied. Continuous operation of the device at the absolute rating level may affect device reliability. All voltages are referenced to device ground.

Notes:

1. Connection to all power and ground pads is required. Duty cycle is limited by the total power dissipated in the package.
2. For operation above 25°C ambient derate linearly to 85°C at 12mW/°C.

Product Marking

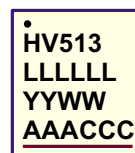

L = Lot Number
YY = Year Sealed
WW = Week Sealed
A = Assembler ID
C = Country of Origin
— = "Green" Packaging

Package may or may not include the following marks: Si or

32-Lead QFN (K7)



YY = Year Sealed
WW = Week Sealed
L = Lot Number
C = Country of Origin
A = Assembler ID*

Bottom Marking

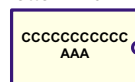

— = "Green" Packaging
*May be part of top marking

Package may or may not include the following marks: Si or

24-Lead SOW (WG)

Typical Operating Conditions

Sym	Parameter	Min	Typ	Max	Units	Conditions
V_{DD}	Logic supply voltage	4.5	5.0	5.5	V	---
V_{PP}	High voltage supply	50	-	250	V	Note 1
V_{IH}	High-level input voltage	V_{DD} -0.9	-	V_{DD}	V	---
V_{IL}	Low-level input voltage	0	-	0.9	V	---
T_J	Operating junction temperature	-40	-	+85	°C	---

Notes:

1. Below minimum V_{PP} the output may not switch.
2. Power-up sequence should be the following:
 1. Connect ground
 2. Apply V_{DD}
 3. Set all inputs (Data, CLK, Enable, etc.) to a known state
 4. Apply V_{PP}

Power-down sequence should be the reverse of the above

DC Electrical Characteristics (Over typical operating conditions unless otherwise specified, $T_j = 25^\circ\text{C}$)

Sym	Parameter	Min	Typ	Max	Units	Conditions	
I_{DD}	V_{DD} supply current	-	-	4.0	mA	$f_{CLK} = 8.0\text{Hz}$, $\overline{LE} = \text{Low}$	
I_{DDQ}	Quiescent V_{DD} supply current	-	-	0.1	mA	All $V_{IN} = V_{DD}$	
		-	-	2.0		All $V_{IN} = 0\text{V}$	
I_{PP}	V_{PP} supply current	-	-	100	μA	$V_{PP} = 250\text{V}$, $f_{OUT} = 300\text{Hz}$, no load	
I_{PPQ}	Quiescent V_{PP} supply current	-	-	100	μA	$V_{PP} = 240\text{V}$, outputs are static	
I_{IH}	High-level logic input current	-	-	10	μA	$V_{IH} = V_{DD}$	
I_{IL}	Low-level logic input current	-	-	-10	μA	$V_{IL} = 0\text{V}$	
		-	-	-350		$V_{IL} = 0\text{V}$, for inputs w/pull-up resistors	
V_{OH}	High level output	HV _{OUT}	140	-	-	V	$V_{PP} = 200\text{V}$, $I_{HVOUT} = -20\text{mA}$
		Data out	$V_{DD} - 1.0\text{V}$	-	-		$I_{DOUT} = -0.1\text{mA}$
V_{OL}	Low level output	HV _{OUT}	-	-	60	V	$V_{DD} = 4.5\text{V}$, $I_{HVOUT} = 20\text{mA}$
		Data out	-	-	1.0		$I_{DOUT} = 0.1\text{mA}$

AC Electrical Characteristics (Over typical operating conditions unless otherwise specified, $T_j = 25^\circ\text{C}$)

Sym	Parameter	Min	Typ	Max	Units	Conditions
f_{CLK}	Clock frequency	0	-	8.0	MHz	---
f_{OUT}	Output switching frequency (SOA limited)	-	300	-	Hz	$C_L = 50\text{nF}$, $V_{PP} = 200\text{V}$
t_W	Clock width high and low	62	-	-	ns	---
t_{SU}	Data setup time before clock rises	15	-	-	ns	---
t_H	Data hold time after clock rises	30	-	-	ns	---
t_{WLE}	Width of latch enable pulse	80	-	-	ns	---
t_{DLE}	\overline{LE} delay time after rising edge of clock	35	-	-	ns	---
t_{SLE}	\overline{LE} setup time before rising edge of clock	40	-	-	ns	---
t_{OR}, t_{OF}	HV _{OUT} rise/fall time	-	-	1000	μs	$C_L = 100\text{nF}$, $V_{PP} = 200\text{V}$
$t_{dON/OFF}$	Delay time for output to start rise/fall	-	-	500	ns	---
t_{DHL}	Delay time clock to D _{OUT} high to low	-	-	110	ns	$C_L = 15\text{pF}$
t_{DLH}	Delay time clock to D _{OUT} low to high	-	-	110	ns	$C_L = 15\text{pF}$
t_R, t_F	All logic inputs	-	-	5.0	ns	---
t_{SD}	Output short circuit detection	-	-	500	ns	$C_L = 15\text{pF}$, Short to output fall of $\overline{\text{SHORT}}$
t_{SC}	Output short circuit clear	-	-	3000	ns	Short clear to output rise of $\overline{\text{SHORT}}$
t_{HI-Z}	Output $\overline{\text{HI-Z}}$ state	-	-	500	ns	---

Input and Output Equivalent Circuits

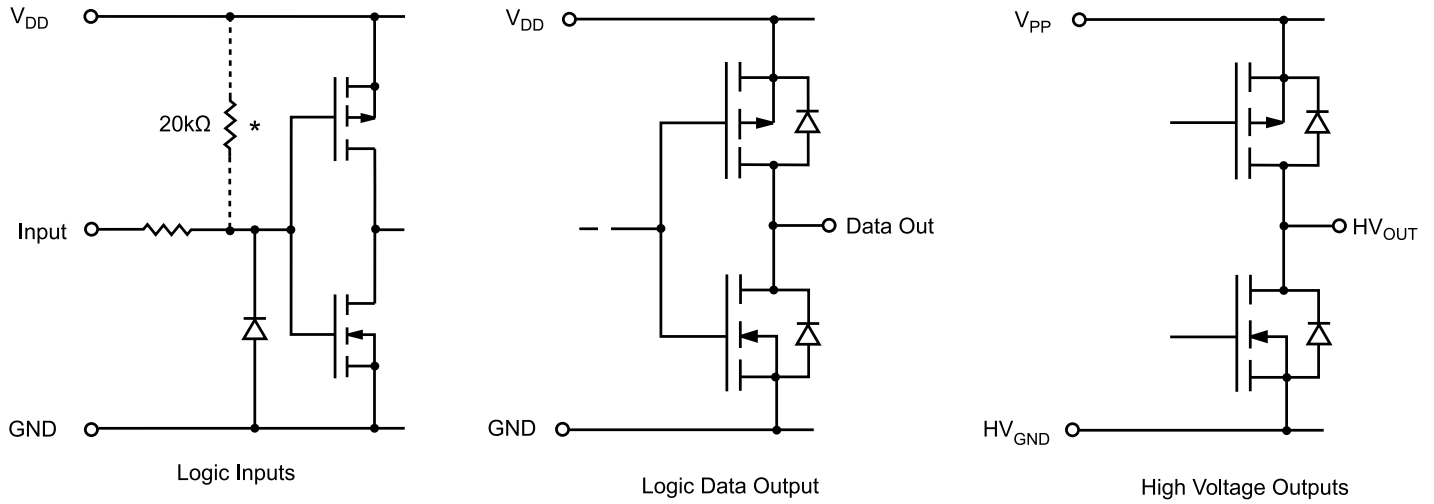

Short Circuit Detect Detail Timing

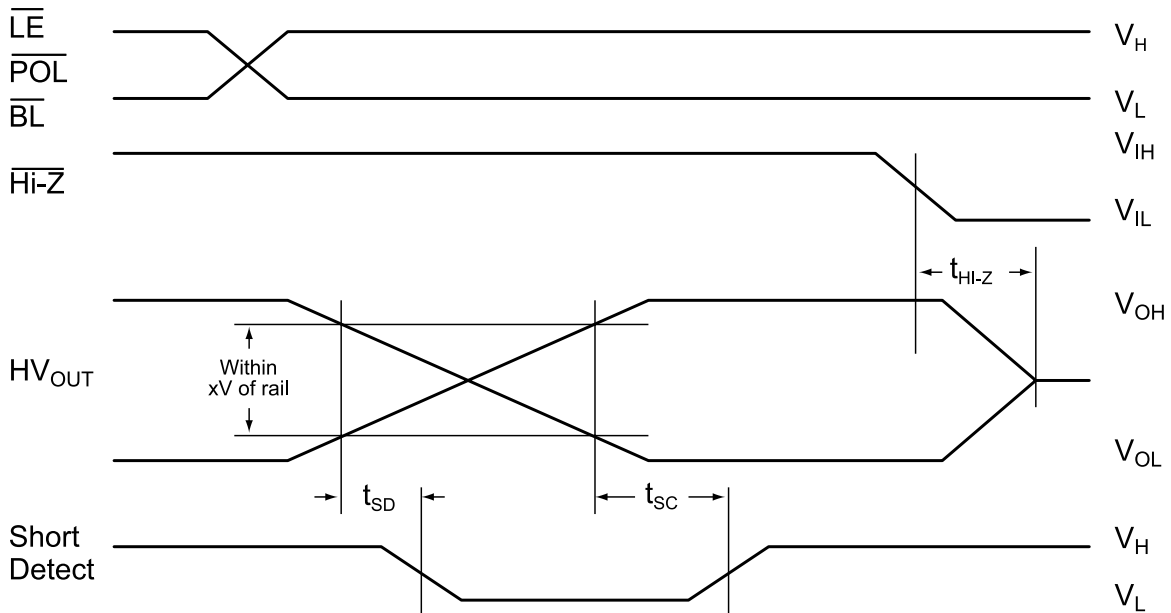

Note:
For V_{PP} greater than 150V:

Short detect output will flag short conditions

- HV_{OUT} is higher than 10V when expected low
- HV_{OUT} is lower than $V_{PP} - 100V$ when expected high

Short detect output will stay clear

- HV_{OUT} is lower than 2.0V when expected low
- HV_{OUT} is higher than $V_{PP} - 60V$ when expected high

Switching Waveforms

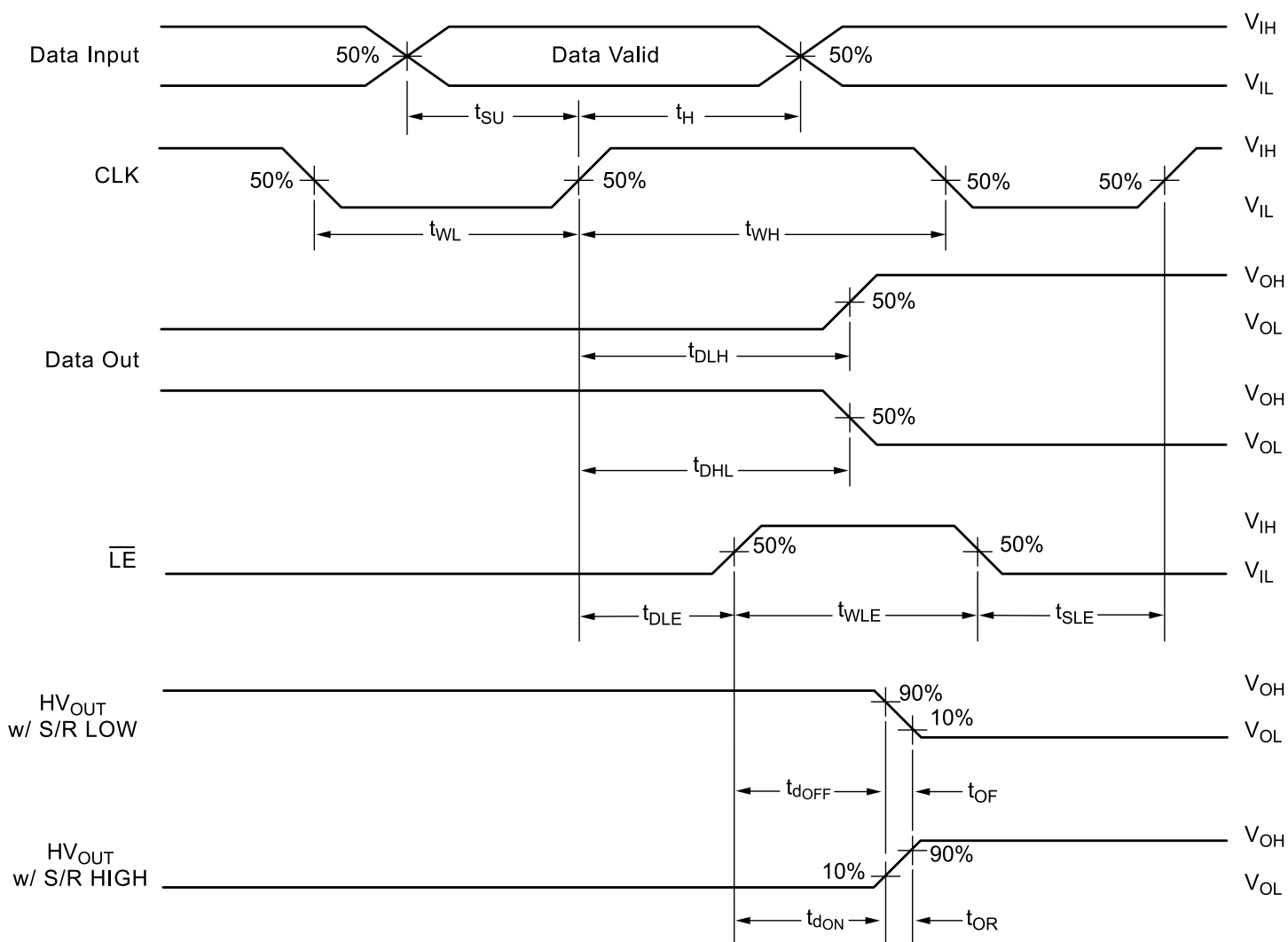

Functional Block Diagram

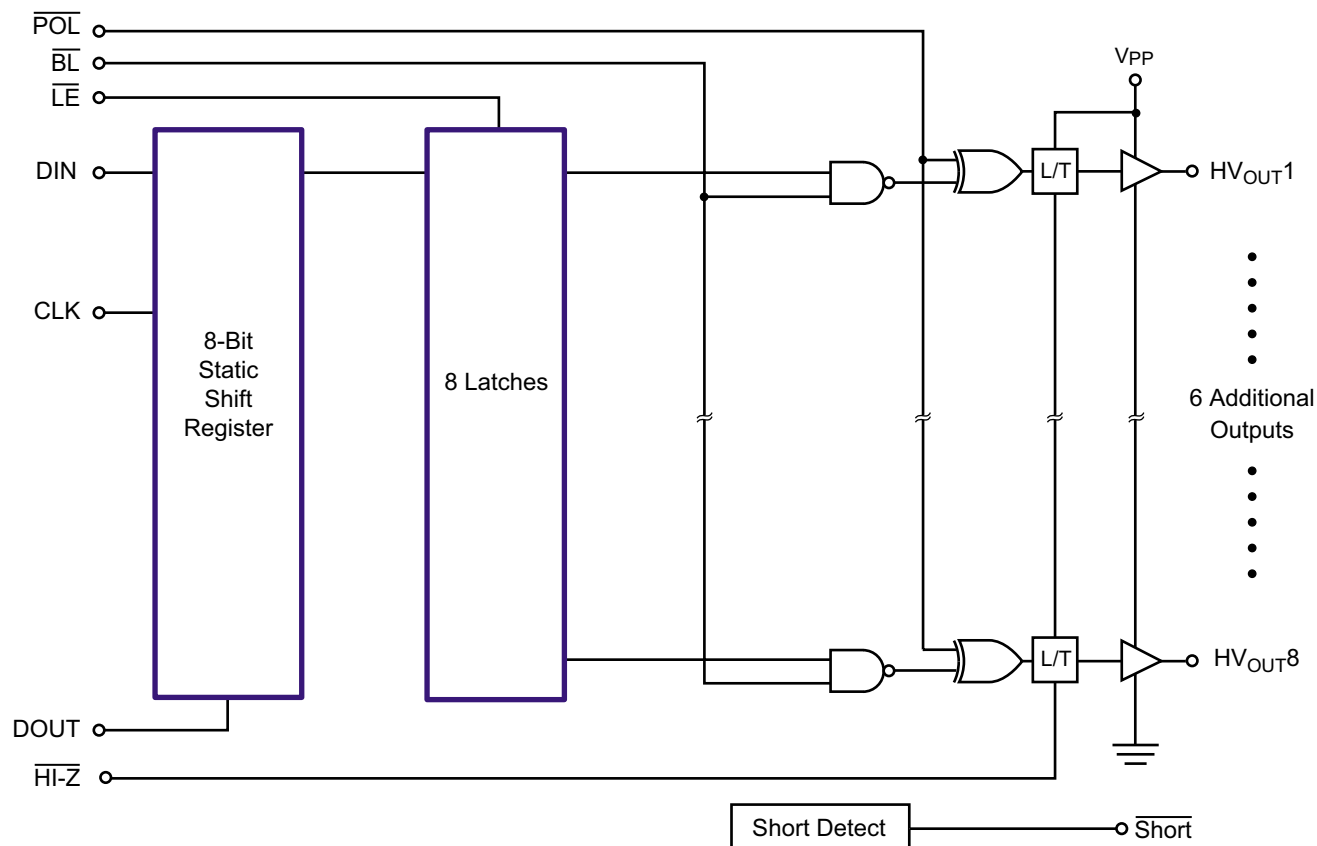

Note: POL, BL, LE, and HI-Z have internal 20kΩ pull-up resistors.

Function Table

Function	Inputs						Outputs		
	Data	CLK	\overline{LE}	\overline{BL}	\overline{POL}	$\overline{HI-Z}$	Shift Reg 1 2...8	HV Outputs 1 2...8	Data Out •
All on	X	X	X	L	L	H	• •...•	H H...H	•
All off	X	X	X	L	H	H	• •...•	L L...L	•
Invert mode	X	X	L	H	L	H	• •...•	• •...• (b)	•
Load S/R	H OR L	↑	L	H	H	H	H or L •...•	• •...•	•
Store data in latches	X	X	L	H	H	H	• •...•	• •...•	•
	X	X	L	H	L	H	• •...•	• •...• (b)	•
Transparent mode	L	↑	H	H	H	H	L •...•	L •...•	•
	H	↑	H	H	H	H	H •...•	H •...•	•
Outputs High-Z	X	X	X	X	X	L	• •...•	High impedance outputs	•
Outputs on	X	X	X	X	X	H	• •...•	• •...•	•

Notes:
 H = high level, L = low level, X = irrelevant, ↑ = low-to-high transition
 • = dependent on previous stage's state before the last CLK or last \overline{LE} high.

Pin Description - 32-Lead QFN (K7)

Pin #	Function	Description
1	NC	No internal connection
2		
3		
4	LGND	Low voltage ground
5	HVGND	High voltage ground
6		
7	NC	No internal connection
8		
9	HV _{OUT} 1	High voltage push-pull output
10	HV _{OUT} 2	High voltage push-pull output
11	HV _{OUT} 3	High voltage push-pull output
12	HV _{OUT} 4	High voltage push-pull output
13	HV _{OUT} 5	High voltage push-pull output
14	HV _{OUT} 6	High voltage push-pull output
15	HV _{OUT} 7	High voltage push-pull output
16	HV _{OUT} 8	High voltage push-pull output
17	NC	No internal connection
18		
19	VPP	High voltage supply
20		
21	VDD	Logic supply voltage
22	DOUT	Data output
23	NC	No internal connection
24		
25	$\overline{\text{BL}}$	Blanking pin, logic input low sets all HV _{OUTS} low
26	NC	No internal connection
27	$\overline{\text{POL}}$	Polarity bar input logic
28	CLK	Clock pin, shift registers shifts data on rising edge of input clock
29	$\overline{\text{LE}}$	Latch enable bar input logic
30	$\overline{\text{SHORT}}$	If output does not reach its required state, SHORT pin will output logic low
31	$\overline{\text{HI-Z}}$	High impedance pin, logic input low sets all outputs in a high impedance state
32	DIN	Data input
Center Pad	V _{PP}	Center pad is at V _{PP} potential. Connect to VPP or leave floating.

Pin Description - 24-Lead SOW (WG)

Pin #	Function	Description
1	NC	No internal connection
2	VDD	Logic supply voltage
3	DOUT	Data output
4	$\overline{\text{BL}}$	Blanking pin, logic input LOW sets all HV _{OUTS} low
5	$\overline{\text{POL}}$	Polarity bar input logic
6	CLK	Clock pin, shift registers shifts data on rising edge of input clock
7	$\overline{\text{LE}}$	Latch enable bar input logic
8	$\overline{\text{SHORT}}$	If output does not reach its required state, SHORT pin will output logic LOW
9	$\overline{\text{HI-Z}}$	High impedance pin, logic input LOW sets all outputs in a high impedance state
10	DIN	Data input
11	LGND	Low voltage ground
12	NC	No internal connection
13	HVGND	High voltage ground
14		
15	HV _{OUT} 1	High voltage push-pull output
16	HV _{OUT} 2	High voltage push-pull output
17	HV _{OUT} 3	High voltage push-pull output
18	HV _{OUT} 4	High voltage push-pull output
19	HV _{OUT} 5	High voltage push-pull output
20	HV _{OUT} 6	High voltage push-pull output
21	HV _{OUT} 7	High voltage push-pull output
22	HV _{OUT} 8	High voltage push-pull output
23	VPP	High voltage supply
24		

32-Lead QFN Package Outline (K7)

6.00x6.00mm body, 0.80mm height (max), 0.50mm pitch

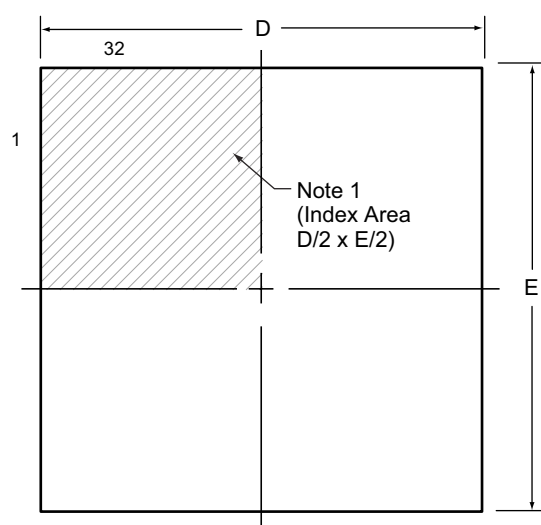

Top View

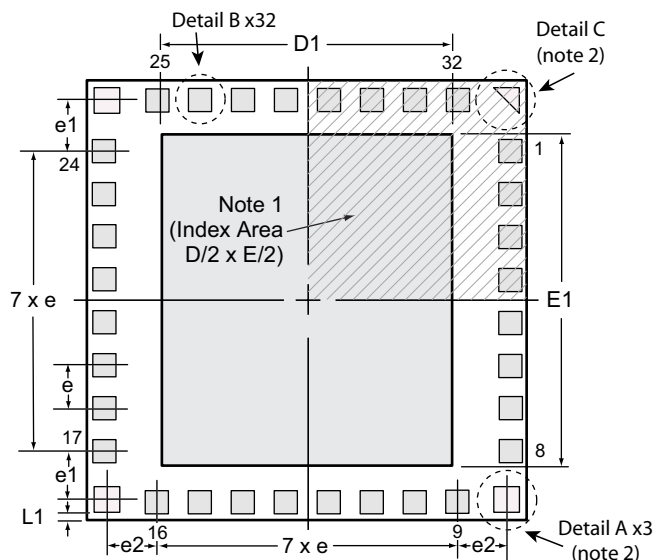

Bottom View

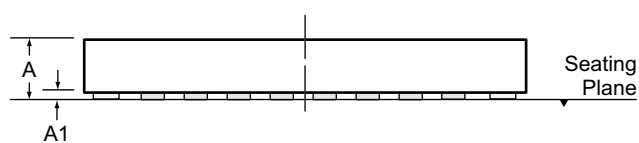

Top View

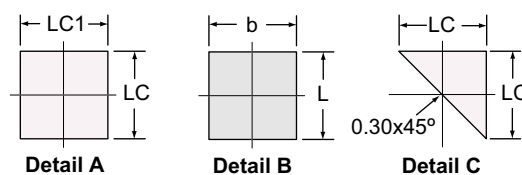

Detail A

Detail B

Detail C

Notes:

1. A Pin 1 identifier must be located in the index area indicated. The Pin 1 identifier can be: a molded mark/identifier; an embedded metal marker; or a printed indicator.
2. The 4 corner pads are for mechanical placement only, they are not internally connected.

Symbol	A	A1	b	D	D1	E	E1	e	e1	e2	L	L1	LC	LC1
Dimension (mm)	MIN	0.70	0.00	0.20	5.90	3.20	5.90	4.30	0.50 BSC	1.00 REF	0.975 REF	0.20	0.10 REF	0.20
	NOM	0.75	-	0.30	6.00	3.30	6.00	4.40						0.30
	MAX	0.80	0.05	0.40	6.10	3.40	6.10	4.50						0.40

Drawings not to scale.

Supertex Doc. #: DSPD-32QFNK76X6P050, Version B101008.

24-Lead SOW (Wide Body) Package Outline (WG)

15.40x7.50 body, 2.65mm height (max), 1.27mm pitch

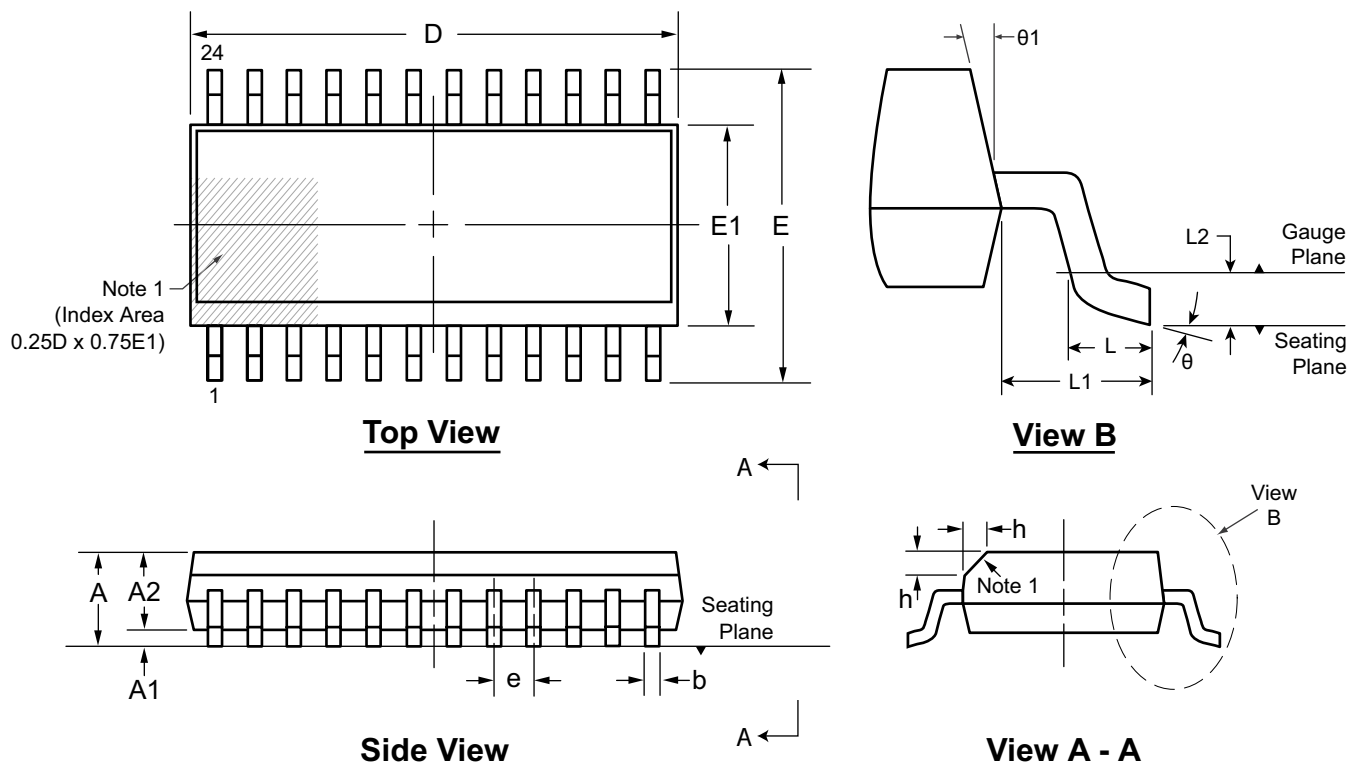

Note:
 1. A Pin 1 identifier must be located in the index area indicated. The Pin 1 identifier can be: a molded mark/identifier; an embedded metal marker; or a printed indicator.

Symbol	A	A1	A2	b	D	E	E1	e	h	L	L1	L2	θ	θ1	
Dimension (mm)	MIN	2.15*	0.10	2.05	0.31	15.20*	9.97*	7.40*	1.27 BSC	0.25	0.40	1.40 REF	0.25 BSC	0°	5°
	NOM	-	-	-	-	15.40	10.30	7.50		-	-			-	-
	MAX	2.65	0.30	2.55*	0.51	15.60*	10.63*	7.60*		0.75	1.27			8°	15°

JEDEC Registration MS-013, Variation AD, Issue E, Sep. 2005.

* This dimension is not specified in the JEDEC drawing.

Drawings are not to scale.

Supertex Doc. #: DSPD-24SOWWG, Version E041309.

(The package drawing(s) in this data sheet may not reflect the most current specifications. For the latest package outline information go to <http://www.supertex.com/packaging.html>.)

Supertex inc. does not warrant the use of its products in life support applications, and will not knowingly sell them for use in such applications unless it receives an adequate "product liability indemnification insurance agreement." Supertex inc. does not assume responsibility for use of devices described, and limits its liability to the replacement of the devices determined defective due to workmanship. No responsibility is assumed for possible omissions and inaccuracies. Circuitry and specifications are subject to change without notice. For the latest product specifications refer to the Supertex inc. website: <http://www.supertex.com>.