

# 64-Channel Serial to Parallel Converter with P-Channel Open Drain Controllable Output Current

## Features

- ▶ HVCMOS® technology
- ▶ 5.0V CMOS Logic
- ▶ Output voltage up to -85V
- ▶ Output current source control
- ▶ 16MHz equivalent data rate
- ▶ Latched data outputs
- ▶ Forward and reverse shifting options (DIR pin)
- ▶ Diode to VDD allows efficient power recovery
- ▶ Hi-Rel processing available

## General Description

The HV57009 is a low-voltage serial to high-voltage parallel converter with P-channel open drain outputs. This device has been designed for use as a driver for plasma panels.

The device has two parallel 32-bit shift registers, permitting data rates twice the speed of one (they are clocked together). There are also 64 latches and control logic to perform the blanking of the outputs. HV<sub>OUT1</sub> is connected to the first stage of the first shift register through the blanking logic. Data is shifted through the shift registers on the logic low to high transition of the clock. The DIR pin causes CCW shifting when connected to VSS, and CW shifting when connected to VDD. A data output buffer is provided for cascading devices. This output reflects the current status of the last bit of the shift register (HV<sub>OUT64</sub>). Operation of the shift register is not affected by the  $\overline{LE}$  (latch enable), or the  $\overline{BL}$  (blanking) inputs. Transfer of data from the shift registers to latches occurs when the  $\overline{LE}$  input is high. The data in the latches is stored when  $\overline{LE}$  is low.

The HV570 has 64 channels of output constant current sourcing capability. They are adjustable from 0.1 to 2.0mA through one external resistor or a current source.

## Functional Block Diagram

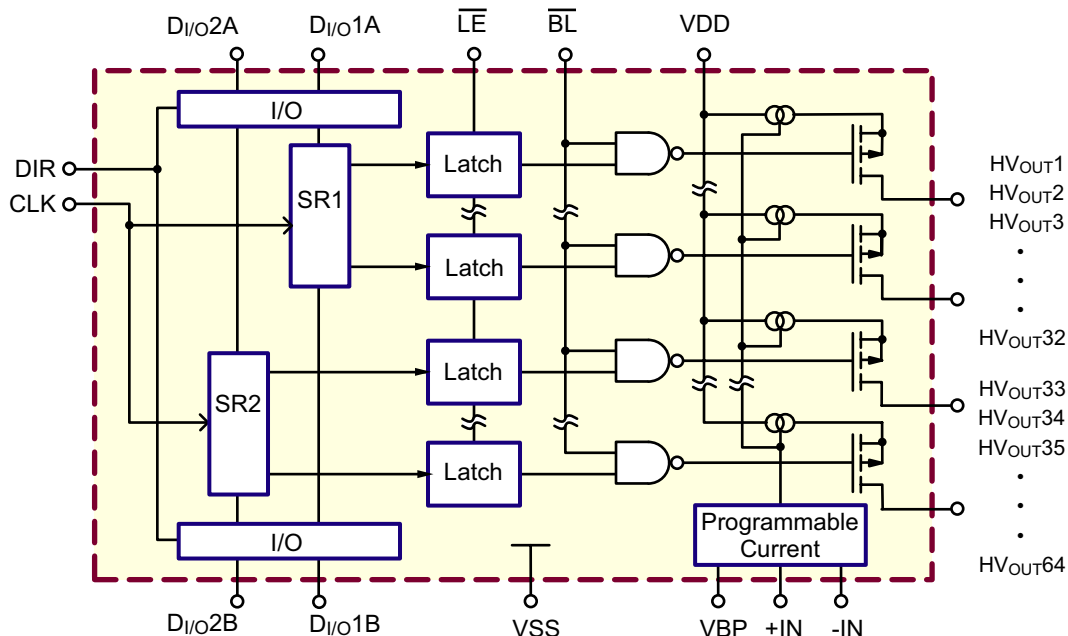

**Note:**  
Each SR (shift register) provides 32 outputs. SR1 supplies outputs 1 to 32 and SR2 supplies outputs 33 to 64.

## Ordering Information

Device	Package Options	
	80-Lead PQFP 20.00x14.00mm body 3.4mm height (max) 0.65mm pitch	Die
HV57009	HV57009PG-G	HV57009X

-G indicates package is RoHS compliant ("Green")



## Absolute Maximum Ratings

Parameter	Value
Supply voltage, $V_{DD}^1$	-0.5V to +7.5V
Output voltage, $V_{NN}^1$	$V_{DD} + 0.5V$ to -95V
Logic input levels <sup>1</sup>	-0.3V to $V_{DD} + 0.3V$
Ground current <sup>2</sup>	1.5A
Continuous total power dissipation <sup>3</sup>	1200mW
Operating temperature range	-40°C to +85°C
Storage temperature range	-65°C to +150°C
Lead temperature <sup>4</sup>	260°C

Absolute Maximum Ratings are those values beyond which damage to the device may occur. Functional operation under these conditions is not implied. Continuous operation of the device at the absolute rating level may affect device reliability.

### Notes:

- All voltages are referenced to  $V_{SS}$ .
- Duty cycle is limited by the total power dissipated in the package.
- For operation above 25°C ambient derate linearly to maximum operating temperature at 20mW/°C.
- 1.6mm (1/16inch) from case for 10 seconds

## Pin Configuration

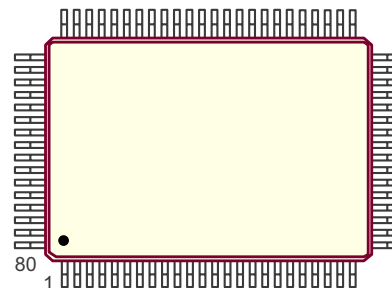

80-Lead PQFP (PG)

## Product Marking

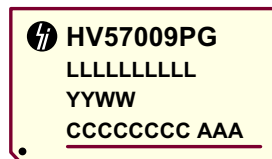

L = Lot Number  
 YY = Year Sealed  
 WW = Week Sealed  
 C = Country of Origin  
 A = Assembler ID  
 — = "Green" Packaging

80-Lead PQFP (PG)

## Recommended Operating Conditions

Sym	Parameter	Min	Max	Units
$V_{DD}$	Logic supply voltage	4.5	5.5	V
$HV_{OUT}$	HV output off voltage	-85	$V_{DD}$	V
$V_{IH}$	High-level input voltage	$V_{DD} - 1.2V$	$V_{DD}$	V
$V_{IL}$	Low-level input voltage	0	1.2	V
$f_{CLK}$	Clock frequency per register	DC	8.0	MHz
			4.5	
$T_A$	Operating free-air temperature	-40	+85	°C

### Notes:

Power-up sequence should be the following:

- Connect ground
- Apply  $V_{DD}$
- Set all inputs to a known state

Power-down sequence should be the reverse of the above.

## DC Electrical Characteristics (All voltages are referenced to $V_{SS}$ , $V_{SS} = 0$ , $T_A = 25^\circ\text{C}$ )

Sym	Parameter	Min	Max	Units	Conditions	
$I_{DD}$	$V_{DD}$ supply current	-	15	mA	$V_{DD} = V_{DD} \text{ max}$ , $f_{CLK} = 8.0\text{MHz}$	
$I_{NN}$	High voltage supply current	-	-10	$\mu\text{A}$	Outputs off, $HV_{OUT} = -85\text{V}$ (total of all outputs)	
$I_{DDQ}$	Quiescent $V_{DD}$ supply current	-	100	$\mu\text{A}$	All inputs = $V_{DD}$ , except $+IN = V_{SS} = \text{GND}$	
$V_{OH}$	High level output	Data Out	$V_{DD} - 0.5\text{V}$	-	V	$I_O = -100\mu\text{A}$
		$HV_{OUT}$	+1.0	$V_{DD}$	V	$I_O = -2.0\text{mA}$
$V_{OL}$	Low level output	Data Out	-	+0.5	V	$I_O = 100\mu\text{A}$
$I_{IH}$	High-level logic input current	-	1.0	$\mu\text{A}$	$V_{IH} = V_{DD}$	
$I_{IL}$	Low-level logic input current	-	-1.0	$\mu\text{A}$	$V_{IL} = 0\text{V}$	
$I_{CS}$	High output source current	-	-2.0	mA	$V_{REF} = 2.0\text{V}$ , $R_{EXT} = 1.0\text{K}\Omega$ , see Figures 1a and 1b	
		-0.1	-		$V_{REF} = 0.1\text{V}$ , $R_{EXT} = 1.0\text{K}\Omega$ , see Figures 1a and 1b	
$\Delta I_{CS}$	HV output source current for $I_{REF} = 2.0\text{mA}$	-	10	%	$V_{REF} = 2.0\text{V}$ , $R_{EXT} = 1.0\text{K}\Omega$	

**Note:**

Current going out of the chip is considered negative.

## AC Electrical Characteristics (Logic signal inputs and data inputs have $t_r, t_f \leq 5\text{ns}$ [10% and 90% points] for measurements)

Sym	Parameter	Min	Max	Units	Conditions
$f_{CLK}$	Clock frequency	DC	8.0	MHz	Per register
			4.5		When cascading devices
$t_{WL}, t_{WH}$	Clock width high or low	62	-	ns	---
$t_{SU}$	Data set-up time before clock rises	20	-	ns	---
$t_H$	Data hold time after clock rises	15	-	ns	---
$t_{ON}, t_{OFF}$	Time from latch enable to $HV_{OUT}$	-	500	ns	$C_L = 15\text{pF}$
$t_{DHL}$	Delay time clock to data high to low	-	150	ns	$C_L = 15\text{pF}$
$t_{DLH}$	Delay time clock to data low to high	-	150	ns	$C_L = 15\text{pF}$
$t_{DLE}$	Delay time clock to $\overline{LE}$ low to high	45	-	ns	---
$t_{WLE}$	$\overline{LE}$ pulse width	25	-	ns	---
$t_{SLE}$	$\overline{LE}$ set-up time before clock rises	0	-	ns	---
$t_r, t_f$	Max. allowable clock rise and fall time (10% and 90% points)	-	100	ns	---

## Input and Output Equivalent Circuits

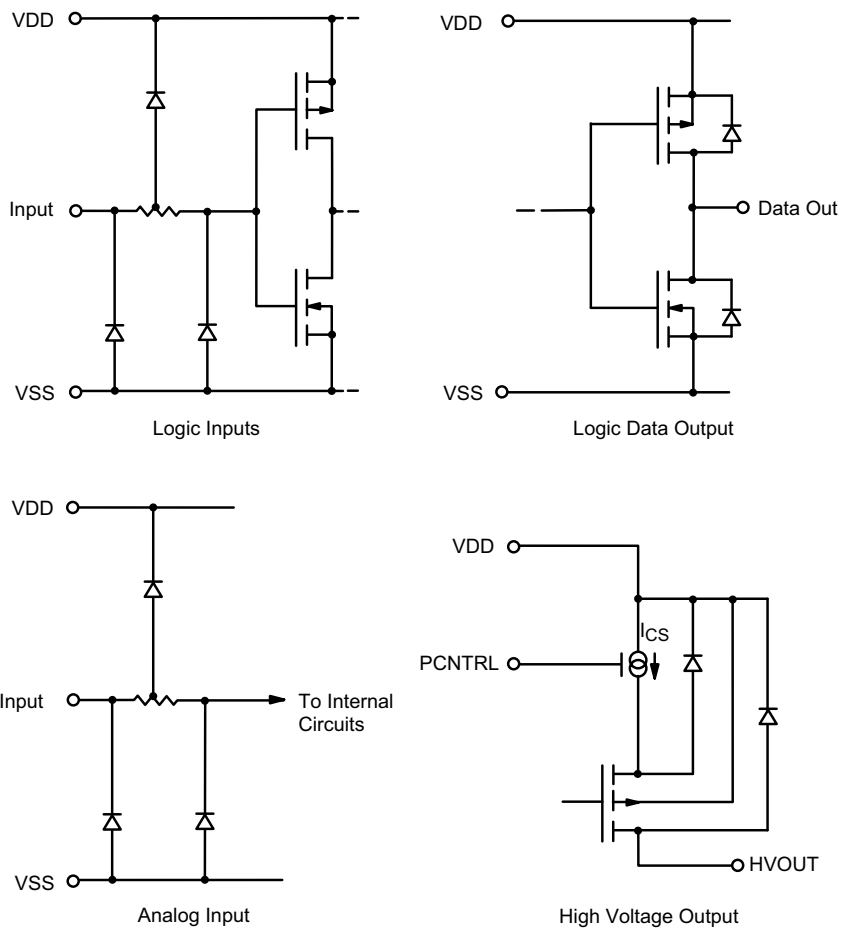

## Shift Register Operation

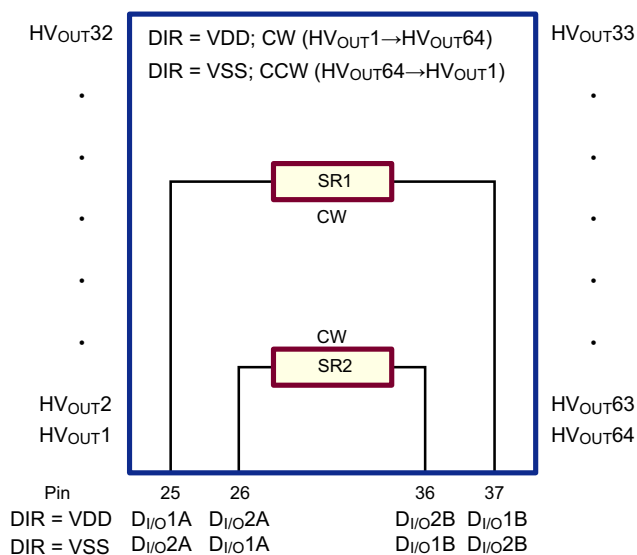

## Switching Waveforms

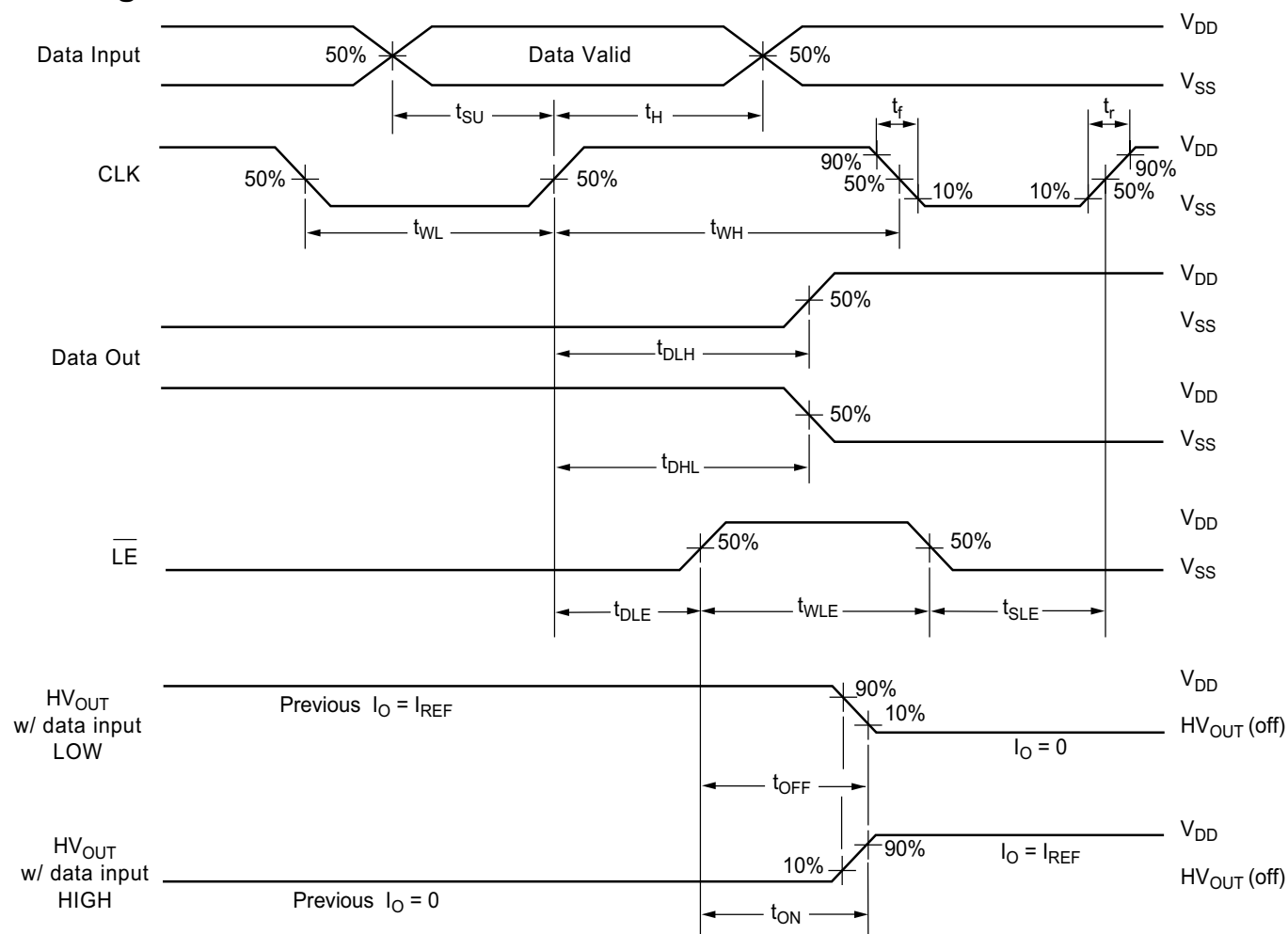

## Function Table

Function	Inputs					Outputs		
	Data In	CLK	$\overline{LE}$	$\overline{BL}$	DIR	Shift Reg	HV Outputs	Data Out
All O/P high	X	X	X	L	X	*	ON	*
Data falls through (latches transparent)	L	$\_ \uparrow \_$	H	H	X	L.....L	ON	L
	H	$\_ \uparrow \_$	H	H	X	H.....H	OFF	H
Data stored in latches	X	X	L	H	X	*	Inversion of stored data	*
I/O relation	$D_{I/O} 1-2A$	$\_ \uparrow \_$	H	H	H	$Q_n \rightarrow Q_{n+1}$	New ON or OFF	$D_{I/O} 1-2B$
	$D_{I/O} 1-2A$	$\_ \uparrow \_$	L	H	H	$Q_n \rightarrow Q_{n+1}$	Previous ON or OFF	$D_{I/O} 1-2B$
	$D_{I/O} 1-2B$	$\_ \uparrow \_$	L	H	L	$Q_n \rightarrow Q_{n-1}$	Previous ON or OFF	$D_{I/O} 1-2A$
	$D_{I/O} 1-2B$	$\_ \uparrow \_$	H	H	L	$Q_n \rightarrow Q_{n-1}$	New ON or OFF	$D_{I/O} 1-2A$

**Note:**

\* = dependent on previous stage's state. See Figure 7 for DIN and DOUT pin designation for CW and CCW shift.

H = V<sub>DD</sub> (Logic)/V<sub>NN</sub> (HV Outputs)

L = V<sub>SS</sub>

## Typical Current Programming Circuits

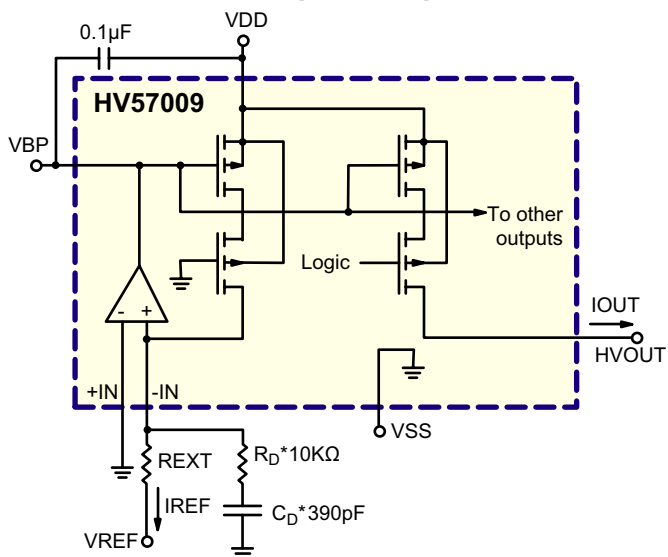

**Figure 1a: Negative Control**

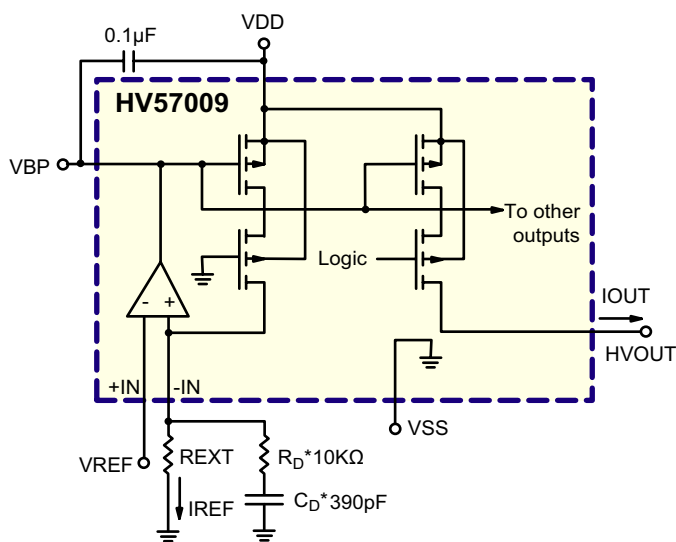

**Figure 1b: Positive Control**

\*Required if  $R_{EXT} > 10K\Omega$  or  $R_{EXT}$  is replaced by a constant current source.

Since  $I_{OUT} = I_{REF} = |V_{REF}| / R_{EXT}$

Therefore:

If  $I_{OUT} = 2.0mA$  and  $V_{REF} = -5.0V \rightarrow R_{EXT} = 2.5K\Omega$ .

If  $I_{OUT} = 1.0mA$  and  $R_{EXT} = 1.0K\Omega \rightarrow V_{REF} = -1.0V$ .

If  $R_{EXT} > 10K\Omega$ , add series network  $R_D$  and  $C_D$  to ground for stability as shown.

This control method behaves linearly as long as the operational amplifier is not saturated. However, it requires a negative power source and needs to provide a current  $I_{REF} = I_{OUT}$  for each HV570 chip being controlled.

If  $HV_{OUT} \geq +1.0V$ , the  $HV_{OUT}$  cascade may no longer operate as a perfect current source, and the output current will diminish. This effect depends on the magnitude of the output current.

Given  $I_{OUT}$  and  $V_{REF}$ , the  $R_{EXT}$  can be calculated by using:

$R_{EXT} = V_{REF} / I_{REF} = V_{REF} / I_{OUT}$

The intersection of a set of  $I_{OUT}$  and  $V_{REF}$  values can be located in the graph shown below. The value picked for  $R_{EXT}$  must always be in the shaded area for linear operation. This control method has the advantage that  $V_{REF}$  is positive, and draws only leakage current. If  $R_{EXT} > 10K\Omega$ , add series network  $R_D$  and  $C_D$  to ground for stability as shown.

**Note:**

Lower reference current  $I_{REF}$  results in higher distortion,  $\Delta I_{CS}$ , on the output.

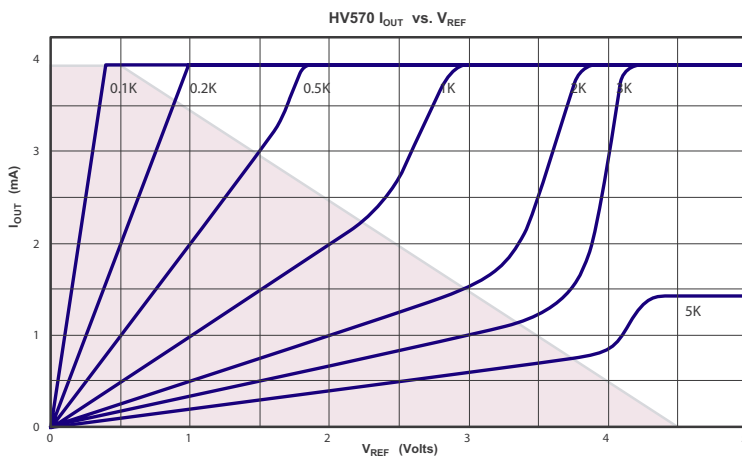

## Pin Function

Pin #	Function	Pin #	Function	Pin #	Function	Pin #	Function
1	HV <sub>OUT</sub> 24	21	HV <sub>OUT</sub> 4	41	HV <sub>OUT</sub> 64	61	HV <sub>OUT</sub> 44
2	HV <sub>OUT</sub> 23	22	HV <sub>OUT</sub> 3	42	HV <sub>OUT</sub> 63	62	HV <sub>OUT</sub> 43
3	HV <sub>OUT</sub> 22	23	HV <sub>OUT</sub> 2	43	HV <sub>OUT</sub> 62	63	HV <sub>OUT</sub> 42
4	HV <sub>OUT</sub> 21	24	HV <sub>OUT</sub> 1	44	HV <sub>OUT</sub> 61	64	HV <sub>OUT</sub> 41
5	HV <sub>OUT</sub> 20	25	D <sub>I/O</sub> 1A	45	HV <sub>OUT</sub> 60	65	HV <sub>OUT</sub> 40
6	HV <sub>OUT</sub> 19	26	D <sub>I/O</sub> 2A	46	HV <sub>OUT</sub> 59	66	HV <sub>OUT</sub> 39
7	HV <sub>OUT</sub> 18	27	NC	47	HV <sub>OUT</sub> 58	67	HV <sub>OUT</sub> 38
8	HV <sub>OUT</sub> 17	28	NC	48	HV <sub>OUT</sub> 57	68	HV <sub>OUT</sub> 37
9	HV <sub>OUT</sub> 16	29	$\overline{\text{LE}}$	49	HV <sub>OUT</sub> 56	69	HV <sub>OUT</sub> 36
10	HV <sub>OUT</sub> 15	30	CLK	50	HV <sub>OUT</sub> 55	70	HV <sub>OUT</sub> 35
11	HV <sub>OUT</sub> 14	31	$\overline{\text{BL}}$	51	HV <sub>OUT</sub> 54	71	HV <sub>OUT</sub> 34
12	HV <sub>OUT</sub> 13	32	VSS	52	HV <sub>OUT</sub> 53	72	HV <sub>OUT</sub> 33
13	HV <sub>OUT</sub> 12	33	DIR	53	HV <sub>OUT</sub> 52	73	HV <sub>OUT</sub> 32
14	HV <sub>OUT</sub> 11	34	VDD	54	HV <sub>OUT</sub> 51	74	HV <sub>OUT</sub> 31
15	HV <sub>OUT</sub> 10	35	-IN	55	HV <sub>OUT</sub> 50	75	HV <sub>OUT</sub> 30
16	HV <sub>OUT</sub> 9	36	D <sub>I/O</sub> 2B	56	HV <sub>OUT</sub> 49	76	HV <sub>OUT</sub> 29
17	HV <sub>OUT</sub> 8	37	D <sub>I/O</sub> 1B	57	HV <sub>OUT</sub> 48	77	HV <sub>OUT</sub> 28
18	HV <sub>OUT</sub> 7	38	NC	58	HV <sub>OUT</sub> 47	78	HV <sub>OUT</sub> 27
19	HV <sub>OUT</sub> 6	39	+IN	59	HV <sub>OUT</sub> 46	79	HV <sub>OUT</sub> 26
20	HV <sub>OUT</sub> 5	40	VBP	60	HV <sub>OUT</sub> 45	80	HV <sub>OUT</sub> 25

## Notes:

1. Pin designation for DIR = VDD.
2. A 0.1 $\mu$ F capacitor is needed between VDD and VBP (pin 40) for better output current stability and to prevent transient cross-coupling between outputs. See Figures 1a and 1b.

# 80-Lead PQFP Package Outline (PG)

20.00x14.00mm body, 3.40mm height (max), 0.80mm pitch, 3.90mm footprint

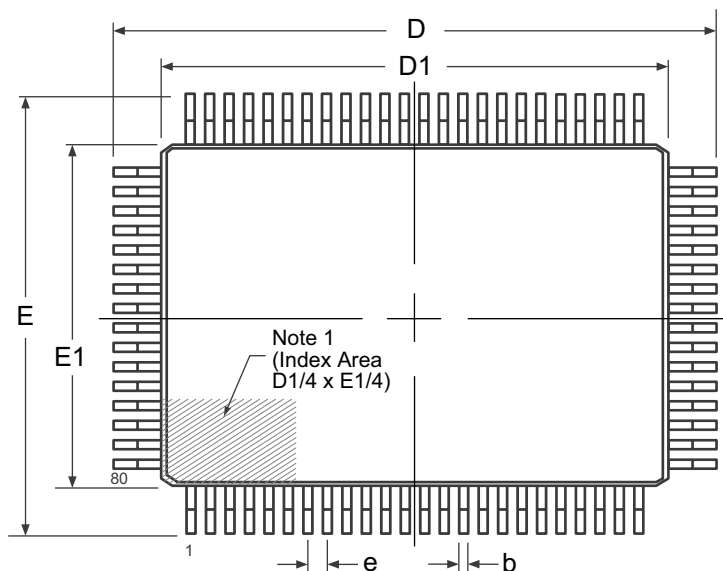

**Top View**

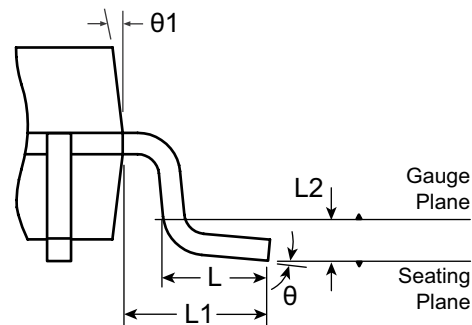

**View B**

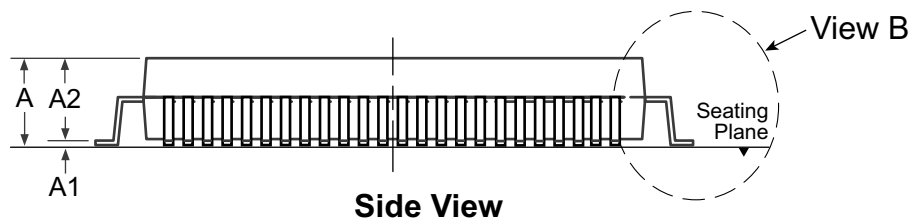

**Side View**

**Note:**  
 1. A Pin 1 identifier must be located in the index area indicated. The Pin 1 identifier can be: a molded mark/identifier; an embedded metal marker; or a printed indicator.

Symbol		A	A1	A2	b	D	D1	E	E1	e	L	L1	L2	$\theta$	$\theta_1$
Dimension (mm)	MIN	2.80*	0.25	2.55	0.30	23.65*	19.80*	17.65*	13.80*	0.80 BSC	0.73	1.95 REF	0.25 BSC	0°	5°
	NOM	-	-	2.80	-	23.90	20.00	17.90	14.00		0.88			3.5°	-
	MAX	3.40	0.50*	3.05	0.45	24.15*	20.20*	18.15*	14.20*		1.03			7°	16°

JEDEC Registration MO-112, Variation CB-1, Issue B, Sept. 1995.

\* This dimension is not specified in the original JEDEC drawing. The value listed is for reference only.

Drawings not to scale.

Supertex Doc. #: DSPD-80PQFPPG, Version B101708.

(The package drawing(s) in this data sheet may not reflect the most current specifications. For the latest package outline information go to <http://www.supertex.com/packaging.html>.)

Supertex inc. does not recommend the use of its products in life support applications, and will not knowingly sell them for use in such applications unless it receives an adequate "product liability indemnification insurance agreement." Supertex inc. does not assume responsibility for use of devices described, and limits its liability to the replacement of the devices determined defective due to workmanship. No responsibility is assumed for possible omissions and inaccuracies. Circuitry and specifications are subject to change without notice. For the latest product specifications refer to the Supertex inc. website: <http://www.supertex.com>.