

## 32-Channel Serial to Parallel Converter with P-Channel Open Drain Outputs

### Features

- ▶ Processed with HVCMOS® Technology
- ▶ Output voltages to -220V
- ▶ Source current minimum 60mA
- ▶ Shift register speed 8.0MHz
- ▶ Polarity and blanking inputs
- ▶ CMOS compatible inputs
- ▶ Forward and reverse shifting options
- ▶ Can be used with the HV5522 to provide 220V push-pull operation
- ▶ 44-lead PLCC surface mount package

### General Description

The HV4522 is a low-voltage serial to high-voltage parallel converter with P-Channel open drain outputs. This device has been designed for use as a driver for AC-electroluminescent displays. It can also be used in any application requiring multiple output high-voltage current source capabilities, such as driving inkjet and electrostatic print heads, plasma panels, or vacuum fluorescent displays.

This device consists of a 32-bit shift register, 32 data latches, and control logic to perform polarity and blanking functions. Data is shifted through the shift register on the logic high-to-low transition of the clock. The HV4522 shifts in the counter clockwise direction (when viewed from the top of the package). A data output buffer is provided for cascading devices. This output reflects the current status of the last bit of the shift register. The data in the shift register is latched when the latch enable pin is brought to logic high, and then returned to ground. If the latch enable pin is held high, the latch becomes transparent and the shift register data is directly reflected in the outputs.

For applications requiring active pull down as well as pull up, the HV4522 can be paired with the HV5522.

### Functional Block Diagram

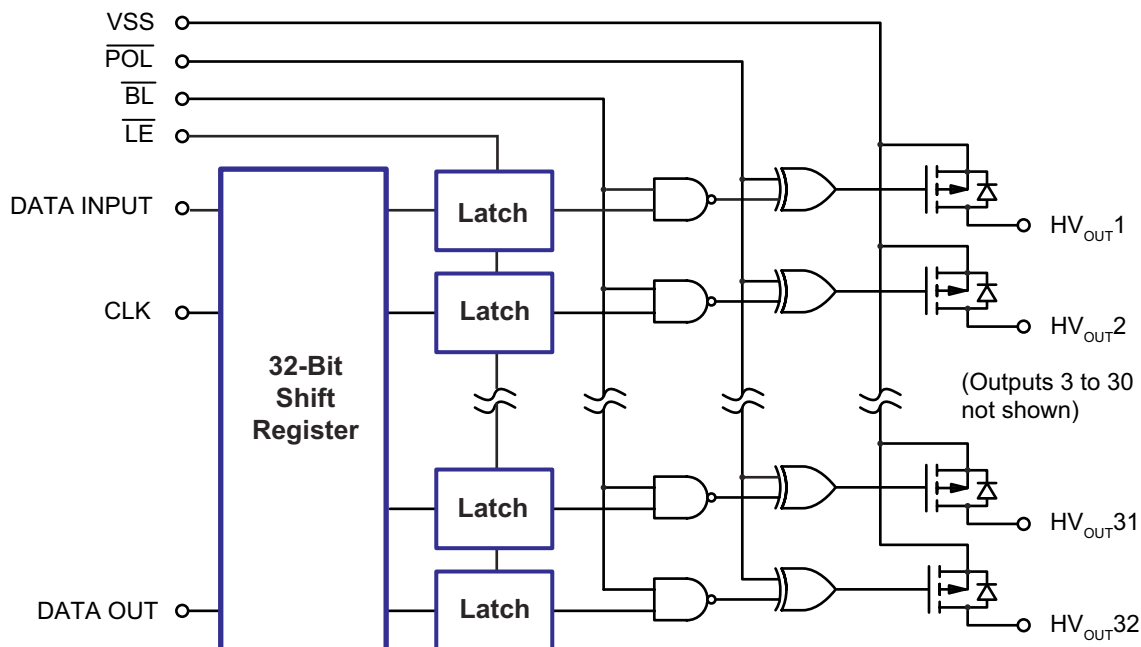

## Ordering Information

Device	Package Option
	<b>44-Lead PLCC</b> .653x.653in body .180in height (max) .050in pitch
HV4522	HV4522PJ-G



-G indicates package is RoHS compliant ("Green")

## Absolute Maximum Ratings

Parameter	Value
Supply voltage, $V_{DD}$	+0.5V to -16V
Output voltage, $V_{PP}$	+0.5V to -240V
Logic input levels	+0.5V to $V_{DD}$ -0.3V
Ground current <sup>(1)</sup>	1.5A
Continuous total power dissipation <sup>(2)</sup>	1200mW
Operating temperature range	-40°C to +85°C
Storage temperature range	-65°C to +150°C

Absolute Maximum Ratings are those values beyond which damage to the device may occur. Functional operation under these conditions is not implied. Continuous operation of the device at the absolute rating level may affect device reliability. All voltages are referenced to  $V_{SS}$ .

### Notes:

- Duty cycle limited by the total power dissipated in the package.
- For operation above 25°C ambient derate linearly to maximum operating temperature at 20mW/°C.

## Pin Configuration

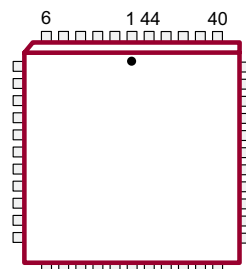

44-Lead PLCC (PJ)  
(top view)

## Product Marking

### Top Marking

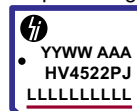

YY = Year Sealed  
 WW = Week Sealed  
 L = Lot Number  
 A = Assembler ID  
 C = Country of Origin\*

### Bottom Marking

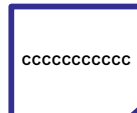

— = "Green" Packaging  
 \*May be part of top marking

Package may or may not include the following marks: Si or

44-Lead PLCC (PJ)

## Recommended Operating Conditions

Sym	Parameter	Min	Max	Units
$V_{DD}$	Logic supply voltage	-10.8	-13.2	V
$V_{PP}$	Output voltage	+0.3	-220	V
$V_{IH}$	High-level input voltage (Logic "1")	$V_{DD}$ +2.0V	$V_{DD}$	V
$V_{IL}$	Low-level input voltage (Logic "0")	0	-2.0	V
$f_{CLK}$	Clock frequency	-	8.0	MHz
$T_A$	Operating free-air temperature	-40	+85	°C

### Note:

All voltages are referenced to  $V_{SS}$

## DC Electrical Characteristics (Over recommended operating conditions unless otherwise noted)

Sym	Parameter	Min	Max	Units	Conditions	
$I_{DD}$	$V_{DD}$ supply current	-	-15	mA	$f_{CLK} = 8.0\text{MHz}$ , $f_{DATA} = 4.0\text{MHz}$	
$I_{DDQ}$	Quiescent $V_{DD}$ supply current	-	-100	$\mu\text{A}$	$V_{IN} = V_{SS}$ or $V_{DD}$	
$I_{O(OFF)}$	Off state output current	-	-100	$\mu\text{A}$	All SWS parallel	
$I_{IH}$	High-level logic input current	-	-1.0	$\mu\text{A}$	$V_{IH} = V_{DD}$	
$I_{IL}$	Low-level logic input current	-	+1.0	$\mu\text{A}$	$V_{IL} = V_{SS}$	
$V_{OH}$	High level output data out	$V_{DD} + 1.0\text{V}$	-	V	$I_{DOUT} = -100\mu\text{A}$	
$V_{OL}$	Low level output	$HV_{OUT}$	-	-30	V	$I_{HVOUT} = -60\text{mA}$
		$D_{OUT}$	-	-1.0	V	$I_{DOUT} = -100\mu\text{A}$
$V_{OC}$	$HV_{OUT}$ clamp voltage	-	+1.5	V	$I_{OL} = +60\text{mA}$	

## AC Electrical Characteristics ( $V_{DD} = -12\text{V}$ , $T_c = 25^\circ\text{C}$ )

Sym	Parameter	Min	Max	Units	Conditions
$f_{CLK}$	Clock frequency	-	8.0	MHz	---
$t_{WH}/t_{WL}$	Clock width high or low	62	-	ns	---
$t_{SU}$	Data set-up time before clock rises	50	-	ns	---
$t_H$	Data hold time after clock rises	20	-	ns	---
$t_{ON}$	Turn on time, $HV_{OUT}$ from enable	-	400	ns	$R_L = 10\text{K}$ to $V_{OO}$ max
$t_{DHL}$	Delay time clock to data high to low	-	100	ns	$C_L = 15\text{pF}$
$t_{DLH}$	Delay time clock to data low to high	-	100	ns	$C_L = 15\text{pF}$
$t_{DLE}$	Delay time clock to $\overline{LE}$ high to low	50	-	ns	---
$t_{WLE}$	$\overline{LE}$ pulse width	50	-	ns	---
$t_{SLE}$	$\overline{LE}$ set-up time before clock rises	50	-	ns	---

## Input and Output Equivalent Circuits

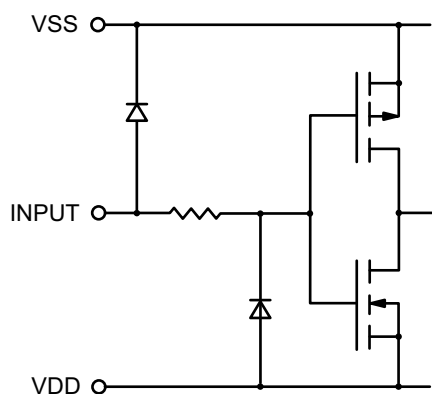

Logic Inputs

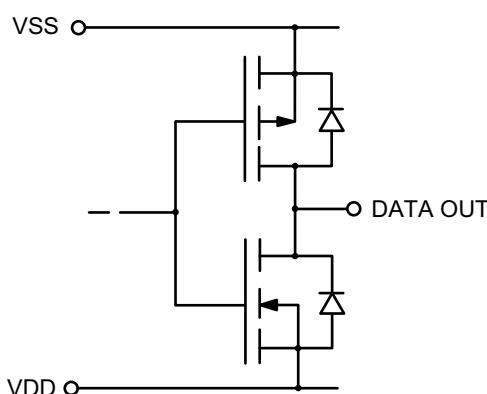

Logic Data Output

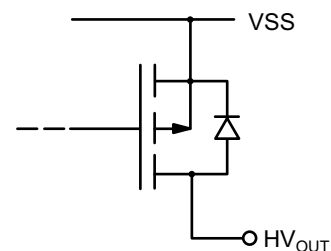

High Voltage Output

## Switching Waveforms

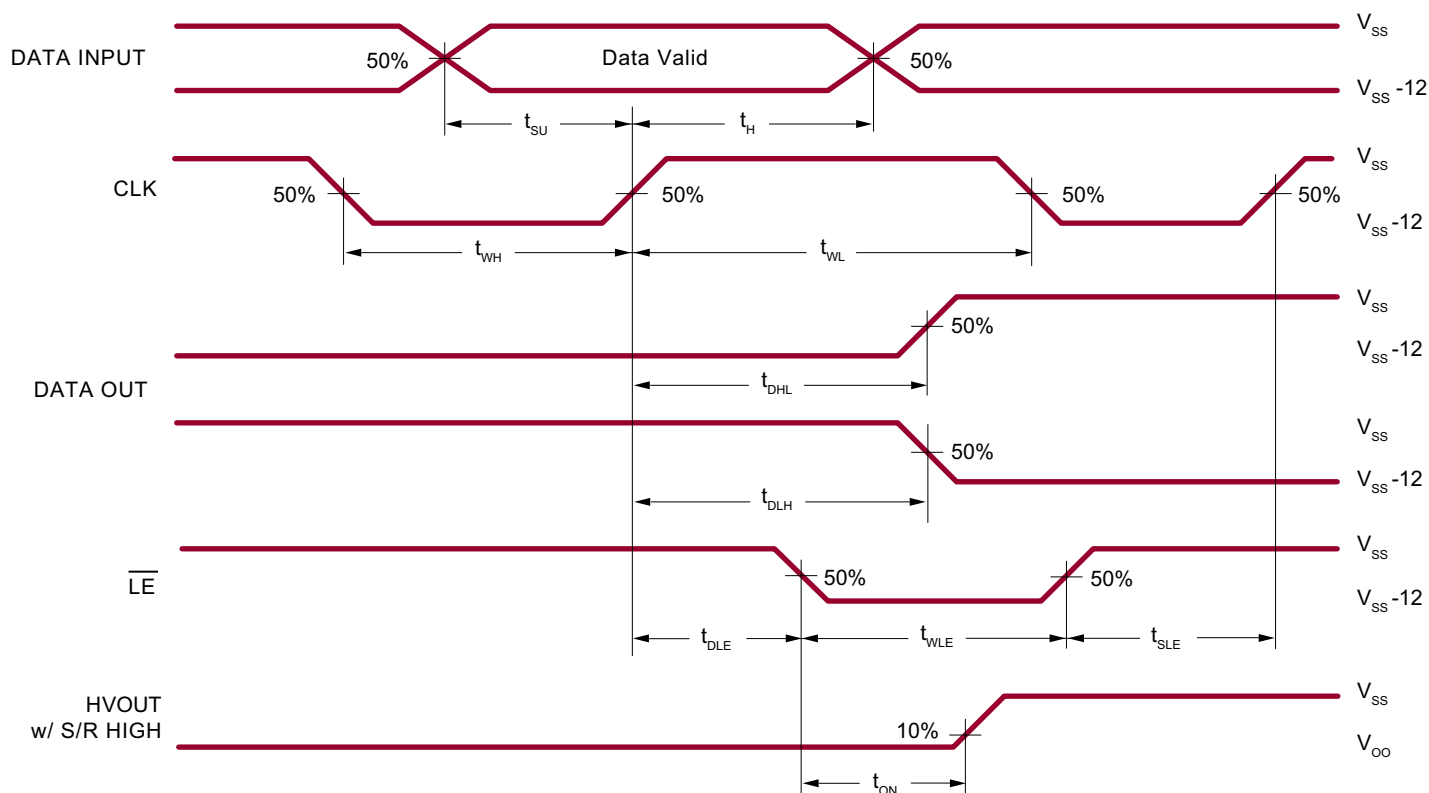

## Function Table

Function	Inputs					Outputs				
	Data	CLK	$\overline{LE}$	$\overline{BL}$	$\overline{POL}$	Shift Reg		HV Outputs		Data Out
						1	2...32	1	2...32	*
All on	X	X	X	L	L	*	*...*	H	H...H	*
All off	X	X	X	L	H	*	*...*	L	L...L	*
Invert mode	X	X	L	H	L	*	*...*	*	*...*	*
Load S/R	H or L	↓	L	H	H	H or L	*...*	*	*...*	*
Load latches	X	H or L	↑	H	H	*	*...*	*	*...*	*
	X	H or L	↑	H	L	*	*...*	*	*...*	*
Transparent latch mode	L	↓	H	H	H	L	*...*	L	*...*	*
	H	↓	H	H	H	H	*...*	H	*...*	*

### Notes:

- H = high level = -12V, L = low level = 0V, X = irrelevant, ↓ = high-to-low transition, ↑ = low-to-high transition.
- \* = dependent on previous stage's state before the last CLK high-to-low transition or last LE high.

## Pin Description

Pin #	Function	Description
1	HV <sub>OUT</sub> 17	High voltage outputs.
2	HV <sub>OUT</sub> 18	
3	HV <sub>OUT</sub> 19	
4	HV <sub>OUT</sub> 20	
5	HV <sub>OUT</sub> 21	
6	HV <sub>OUT</sub> 22	
7	HV <sub>OUT</sub> 23	
8	HV <sub>OUT</sub> 24	
9	HV <sub>OUT</sub> 25	
10	HV <sub>OUT</sub> 26	
11	HV <sub>OUT</sub> 27	
12	HV <sub>OUT</sub> 28	
13	HV <sub>OUT</sub> 28	
14	HV <sub>OUT</sub> 30	
15	HV <sub>OUT</sub> 31	
16	HV <sub>OUT</sub> 32	
17	N/C	No connect.
18	DATA OUT	Data output pin.
19	N/C	No connect.
20	N/C	
21	N/C	
22	$\overline{\text{POL}}$	Inverts the polarity of the HV <sub>OUT</sub> pins
23	CLK	Clock pin, shift registers shifts data on rising edge of input clock.
24	VSS	Reference voltage, usually ground.
25	VDD	Logic supply voltage.
26	$\overline{\text{LE}}$	Logic enable pin, data is shifted from shift register to latches on logic input low.
27	DATA IN	Data input pin.
28	$\overline{\text{BL}}$	Blanking pin, logic input low sets all HV <sub>OUT</sub> pins low.
29	HV <sub>OUT</sub> 1	High voltage outputs.
30	HV <sub>OUT</sub> 2	
31	HV <sub>OUT</sub> 3	
32	HV <sub>OUT</sub> 4	
33	HV <sub>OUT</sub> 5	
34	HV <sub>OUT</sub> 6	
35	HV <sub>OUT</sub> 7	
36	HV <sub>OUT</sub> 8	
37	HV <sub>OUT</sub> 9	
37	HV <sub>OUT</sub> 10	
39	HV <sub>OUT</sub> 11	
40	HV <sub>OUT</sub> 12	
41	HV <sub>OUT</sub> 13	
42	HV <sub>OUT</sub> 14	
43	HV <sub>OUT</sub> 15	
44	HV <sub>OUT</sub> 16	

# 44-Lead PLCC Package Outline (PJ)

.653x.653in body, .180in height (max), .050in pitch

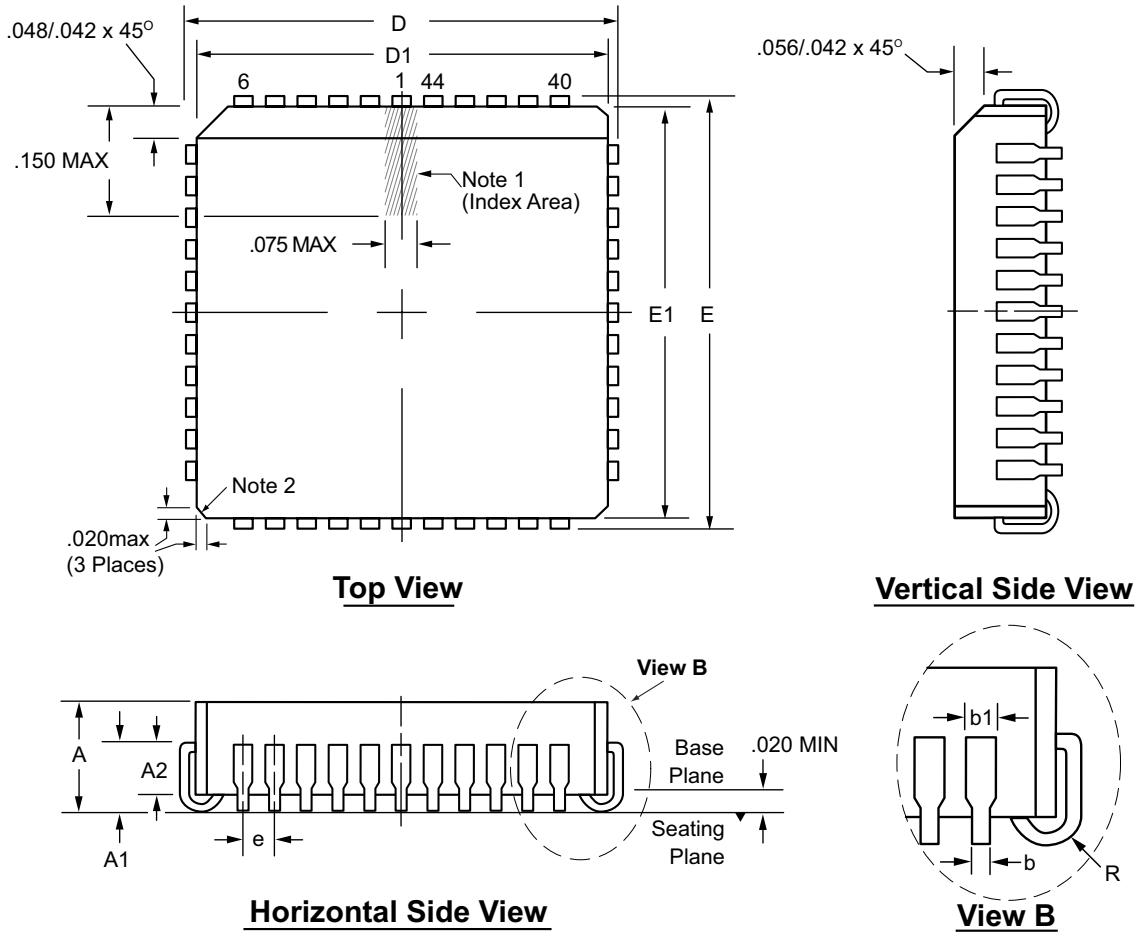

**Notes:**

1. A Pin 1 identifier must be located in the index area indicated. The Pin 1 identifier can be: a molded mark/identifier; an embedded metal marker; or a printed indicator.
2. Actual shape of this feature may vary.

Symbol		A	A1	A2	b	b1	D	D1	E	E1	e	R
Dimension (inches)	MIN	.165	.090	.062	.013	.026	.685	.650	.685	.650	.050 BSC	.025
	NOM	.172	.105	-	-	-	.690	.653	.690	.653		.035
	MAX	.180	.120	.083	.021	.036†	.695	.656	.695	.656		.045

JEDEC Registration MS-018, Variation AC, Issue A, June, 1993.

† This dimension differs from the JEDEC drawing.

Drawings not to scale.

Supertex Doc. #: DSPD-44PLCCPJ, Version F031111.

(The package drawing(s) in this data sheet may not reflect the most current specifications. For the latest package outline information go to <http://www.supertex.com/packaging.html>.)

Supertex inc. does not recommend the use of its products in life support applications, and will not knowingly sell them for use in such applications unless it receives an adequate "product liability indemnification insurance agreement." Supertex inc. does not assume responsibility for use of devices described, and limits its liability to the replacement of the devices determined defective due to workmanship. No responsibility is assumed for possible omissions and inaccuracies. Circuitry and specifications are subject to change without notice. For the latest product specifications refer to the Supertex inc. (website: <http://www.supertex.com>)