

# Low Charge Injection, 24-Channel, High Voltage Analog Switch with Bleed Resistors

## Features

- ▶ 24-channel high voltage analog switch
- ▶ Integrated bleed resistors on the outputs
- ▶ 3.3 or 5.0V CMOS input logic level
- ▶ 3:1 MUX-deMUX with 8 states
- ▶ 20MHz data shift clock frequency
- ▶ HVCMOS technology for high performance
- ▶ Very low quiescent power dissipation, 10µA
- ▶ Low parasitic capacitance
- ▶ DC to 50MHz analog signal frequency
- ▶ -60dB typical OFF-isolation at 5.0MHz
- ▶ CMOS logic circuitry for low power
- ▶ Excellent noise immunity
- ▶ Cascadable serial data register with latches
- ▶ Flexible operating supply voltages

## Applications

- ▶ Medical ultrasound imaging
- ▶ Piezoelectric transducer drivers
- ▶ Inkjet printer heads
- ▶ Optical MEMS modules

## General Description

The Supertex HV2761 is a low charge injection, 24-channel, high voltage analog switch integrated circuit (IC) intended for use in applications requiring high voltage switching controlled by low voltage control signals, such as medical ultrasound imaging, piezoelectric transducer drivers, and printers. The bleed resistors eliminate voltage built up on capacitive loads such as piezoelectric transducers.

Input data is shifted into a 24-bit shift register that can then be retained in a 24-bit latch. To reduce any possible clock feed through noise, the latch enable (LE) should be left high until all bits are clocked in. Data are clocked in during the rising edge of the clock. Using HVCMOS technology, this device combines high voltage bilateral DMOS switches and low power CMOS logic to provide efficient control of high voltage analog signals.

The device is suitable for various combinations of high voltage supplies, e.g.,  $V_{PP}/V_{NN}$ : +40V/-160V, +100V/-100V, and +160V/-40V.

## Block Diagram

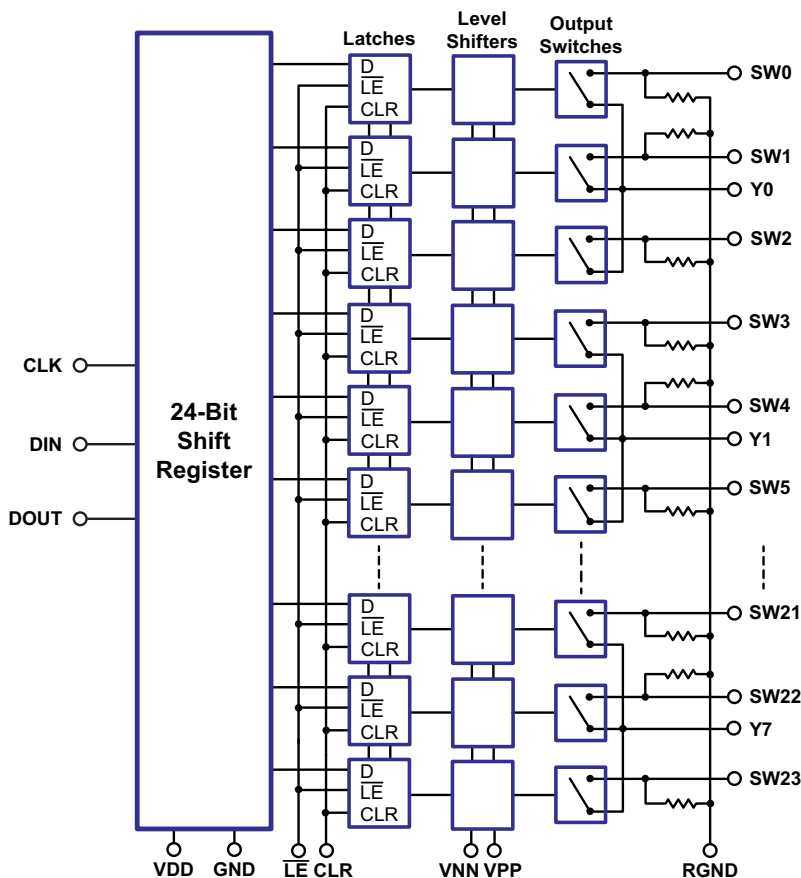

## Ordering Information

Part Number	Package	Packing
HV2761FG-G	48-Lead LQFP	250/Tray
HV2761FG-G M931	48-Lead LQFP	1000/Reel

-G indicates package is RoHS compliant ("Green")



## Pin Configuration

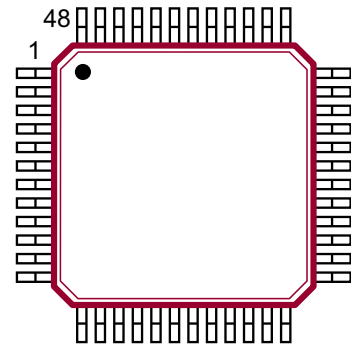

48-Lead LQFP  
(top view)

## Absolute Maximum Ratings

Parameter	Value
V <sub>DD</sub> logic supply	-0.5V to +6.5V
V <sub>PP</sub> - V <sub>NN</sub> differential supply	220V
V <sub>PP</sub> positive supply	-0.5V to V <sub>NN</sub> + 200V
V <sub>NN</sub> negative supply	+0.5V to - 200V
Logic input voltage	-0.5V to V <sub>DD</sub> + 0.3V
Analog signal range	V <sub>NN</sub> to V <sub>PP</sub>
Peak analog signal current/channel	3.0A
Storage temperature	-65°C to 150°C
Power dissipation	1.0W

Absolute Maximum Ratings are those values beyond which damage to the device may occur. Functional operation under these conditions is not implied. Continuous operation of the device at the absolute rating level may affect device reliability. All voltages are referenced to device ground.

## Product Marking

Top Marking



YY = Year Sealed  
WW = Week Sealed

L = Lot Number

C = Country of Origin\*

A = Assembler ID\*

— = "Green" Packaging

\*May be part of top marking

Bottom Marking



Package may or may not include the following marks: Si or

48-Lead LQFP

## Typical Thermal Resistance

Package	$\theta_{ja}$
48-Lead LQFP	52°C/W

## Recommended Operating Conditions

Sym	Parameter	Value
V <sub>DD</sub>	Logic power supply voltage	3.0V to 5.5V
V <sub>PP</sub>	Positive high voltage supply	+40V to V <sub>NN</sub> + 200V
V <sub>NN</sub>	Negative high voltage supply	-40V to - 160V
V <sub>IH</sub>	High level input voltage	0.9V <sub>DD</sub> to V <sub>DD</sub>
V <sub>IL</sub>	Low level input voltage	0V to 0.1V <sub>DD</sub>
V <sub>SIG</sub>	Analog signal voltage peak-to-peak	V <sub>NN</sub> +10V to V <sub>PP</sub> - 10V
T <sub>A</sub>	Operating free air temperature	0°C to 70°C

### Notes:

- Power up/down sequence is arbitrary except GND must be powered-up first and powered-down last.
- V<sub>SIG</sub> must be V<sub>NN</sub> ≤ V<sub>SIG</sub> ≤ V<sub>PP</sub> or floating during power up/down transition.
- Rise and fall times of power supplies V<sub>DD</sub>, V<sub>PP</sub> and V<sub>NN</sub> should not be less than 1.0msec.

**DC Electrical Characteristics** (Over recommended operating conditions unless otherwise specified )

Sym	Parameter	0°C		+25°C			+70°C		Unit	Conditions	
		Min	Max	Min	Typ	Max	Min	Max			
R <sub>ONS</sub>	Small signal switch ON-resistance	-	-	-	26	-	-	-	Ω	I <sub>SIG</sub> = 5.0mA	V <sub>PP</sub> = +40V, V <sub>NN</sub> = -160V
		-	-	-	22	-	-	-		I <sub>SIG</sub> = 200mA	
		-	-	-	22	-	-	-		I <sub>SIG</sub> = 5.0mA	V <sub>PP</sub> = +100V, V <sub>NN</sub> = -100V
		-	-	-	18	-	-	-		I <sub>SIG</sub> = 200mA	
		-	-	-	20	-	-	-		I <sub>SIG</sub> = 5.0mA	V <sub>PP</sub> = +160V, V <sub>NN</sub> = -40V
		-	-	-	16	-	-	-		I <sub>SIG</sub> = 200mA	
ΔR <sub>ONS</sub>	Small signal switch ON-resistance matching	-	20	-	5.0	20	-	20	%	I <sub>SIG</sub> = 5.0mA, V <sub>PP</sub> = +100V, V <sub>NN</sub> = -100V	
R <sub>ONL</sub>	Large signal switch ON-resistance	-	-	-	30	-	-	-	Ω	V <sub>SIG</sub> = V <sub>PP</sub> - 10V, I <sub>SIG</sub> = 1.0A	
R <sub>INT</sub>	Output switch shunt resistance	-	-	20	35	50	-	-	KΩ	Output switch to R <sub>GND</sub> I <sub>RINT</sub> = 0.5mA	
I <sub>SOL</sub>	Switch OFF-leakage per switch	-	5.0	-	1.0	10	-	15	μA	V <sub>SIG</sub> = V <sub>PP</sub> - 10V, V <sub>NN</sub> +10V	
V <sub>OS</sub>	DC offset switch OFF	-	300	-	100	300	-	300	mV	No load	
	DC offset switch ON	-	500	-	100	500	-	500			
I <sub>PPQ</sub>	Quiescent V <sub>PP</sub> supply current	-	-	-	10	50	-	-	μA	All switches OFF	
I <sub>NNQ</sub>	Quiescent V <sub>NN</sub> supply current	-	-	-	-10	-50	-	-			
I <sub>PPQ</sub>	Quiescent V <sub>PP</sub> supply current	-	-	-	10	50	-	-	μA	All switches ON, I <sub>SW</sub> = 5.0mA	
I <sub>NNQ</sub>	Quiescent V <sub>NN</sub> supply current	-	-	-	-10	-50	-	-			
I <sub>SW</sub>	Switch output peak current	-	-	-	2.0	1.3	-	-	A	V <sub>SIG</sub> duty cycle < 0.1%	
f <sub>SW</sub>	Output switching frequency	-	-	-	-	50	-	-	kHz	Duty cycle = 50%	
I <sub>PP</sub>	Average V <sub>PP</sub> supply current	-	4.0	-	-	4.5	-	5.0	mA	V <sub>PP</sub> = +40V, V <sub>NN</sub> = -160V	All output switches are turning ON and OFF at 50kHz with no load
		-	4.0	-	-	4.5	-	5.0		V <sub>PP</sub> = +100V, V <sub>NN</sub> = -100V	
		-	4.0	-	-	4.5	-	5.0		V <sub>PP</sub> = +160V, V <sub>NN</sub> = -40V	
I <sub>NN</sub>	Average V <sub>NN</sub> supply current	-	4.0	-	-	4.5	-	5.0	mA	V <sub>PP</sub> = +40V, V <sub>NN</sub> = -160V	All output switches are turning ON and OFF at 50kHz with no load
		-	4.0	-	-	4.5	-	5.0		V <sub>PP</sub> = +100V, V <sub>NN</sub> = -100V	
		-	4.0	-	-	4.5	-	5.0		V <sub>PP</sub> = +160V, V <sub>NN</sub> = -40V	
I <sub>DD</sub>	Average V <sub>DD</sub> supply current	-	8.0	-	-	8.0	-	8.0	mA	f <sub>CLK</sub> = 5.0MHz, V <sub>DD</sub> = 5.0V	
I <sub>DDQ</sub>	Quiescent V <sub>DD</sub> supply current	-	10	-	-	10	-	10	μA	All logic inputs are static	
I <sub>SOR</sub>	Data out source current	0.45	-	0.45	0.70	-	0.40		mA	V <sub>OUT</sub> = V <sub>DD</sub> - 0.7V	
I <sub>SINK</sub>	Data out sink current	0.45	-	0.45	0.70	-	0.40		mA	V <sub>OUT</sub> = 0.7V	
C <sub>IN</sub>	Logic input capacitance	-	10	-	-	10	-	10	pF	---	

\* See Test Circuits on page 5

## AC Electrical Characteristics (Over recommended operating conditions unless otherwise specified)

Sym	Parameter	0°C		+25°C			+70°C		Unit	Conditions
		Min	Max	Min	Typ	Max	Min	Max		
$t_{SD}$	Set up time before $\overline{LE}$ rises	25	-	25	-	-	25	-	ns	---
$t_{WLE}$	Time width of $\overline{LE}$	56	-	-	56	-	56	-	ns	$V_{DD} = 3.0V$
		12	-	-	12	-	12	-		$V_{DD} = 5.0V$
$t_{DO}$	Clock delay time to data out	25	100	25	78	100	25	100	ns	$V_{DD} = 3.0V$
		15	40	15	30	40	15	40		$V_{DD} = 5.0V$
$t_{WCLR}$	Time width of CLR	55	-	55	-	-	55	-	ns	---
$t_{SU}$	Set up time data to clock	21	-	21	-	-	21	-	ns	$V_{DD} = 3.0V$
		7.0	-	7.0	-	-	7.0	-		$V_{DD} = 5.0V$
$t_H$	Hold time data from clock	5.0	-	5.0	-	-	5.0	-	ns	$V_{DD} = 3.0V$
		7.0	-	7.0	-	-	7.0	-		$V_{DD} = 5.0V$
$f_{CLK}$	Clock frequency	-	8	-	-	8	-	8	MHz	$V_{DD} = 3.0V$
		-	20	-	-	20	-	20		$V_{DD} = 5.0V$
$t_R, t_F$	Clock rise and fall times	-	50	-	-	50	-	50	ns	---
$t_{ON}$	Turn ON time	-	5.0	-	-	5.0	-	5.0	$\mu s$	$V_{SIG} = V_{PP} - 10V,$ $R_{LOAD} = 10k\Omega$
$t_{OFF}$	Turn OFF time	-	5.0	-	-	5.0	-	5.0		
dv/dt	Maximum $V_{SIG}$ slew rate	-	20	-	-	20	-	20	V/ns	$V_{PP} = +40V, V_{NN} = -160V$
		-	20	-	-	20	-	20		$V_{PP} = +100V, V_{NN} = -100V$
		-	20	-	-	20	-	20		$V_{PP} = +160V, V_{NN} = -40V$
$K_O$	OFF isolation	-30	-	-30	-33	-	-30	-	dB	$f = 5.0MHz,$ $1.0k\Omega//15pF$ load
		-58	-	-58	-60	-	-58	-		$f = 5.0MHz, 50\Omega$ load
$K_{CR}$	Switch crosstalk	-60	-	-60	-70	-	-60	-	dB	$f = 5.0MHz, 50\Omega$ load
$I_{ID}$	Output switch isolation diode current	-	300	-	-	300	-	300	mA	300ns pulse width, 2.0% duty cycle
$C_{SG(OFF)}$	OFF capacitance SW to GND	-	14	-	9.0	14	-	14	pF	$V_{SIG} = 0V, f = 1.0MHz$ all SW OFF
	OFF capacitance Y to GND	-	35	-	27	35	-	35		
$C_{SG(ON)}$	ON capacitance SW to GND	-	39	-	30	39	-	39	pF	$V_{SIG} = 0V, f = 1.0MHz$ one SW ON, two SW OFF
	ON capacitance Y to GND	-	39	-	30	39	-	39		
$+V_{SPK}$	Output voltage spike (per switch)	-	-	-	-	150	-	-	mV	$V_{PP} = +40V, V_{NN} = -160V$ $R_{LOAD} = 50\Omega$
$-V_{SPK}$		-	-	-	-	150	-	-		
$+V_{SPK}$		-	-	-	-	150	-	-		$V_{PP} = +100V, V_{NN} = -100V$ $R_{LOAD} = 50\Omega$
$-V_{SPK}$		-	-	-	-	150	-	-		
$+V_{SPK}$		-	-	-	-	150	-	-		$V_{PP} = +160V, V_{NN} = -40V$ $R_{LOAD} = 50\Omega$
$-V_{SPK}$		-	-	-	-	150	-	-		

\* See Test Circuits on page 5

AC Electrical Characteristics (cont.) (Over recommended operating conditions unless otherwise specified)

Sym	Parameter	0°C		+25°C			+70°C		Unit	Conditions
		Min	Max	Min	Typ	Max	Min	Max		
QC	Charge injection (per switch)	-	-	-	820	-	-	-	pC	$V_{PP} = +40V, V_{NN} = -160V$
		-	-	-	600	-	-	-		$V_{PP} = +100V, V_{NN} = -100V$
		-	-	-	350	-	-	-		$V_{PP} = +160V, V_{NN} = -40V$

Test Circuits

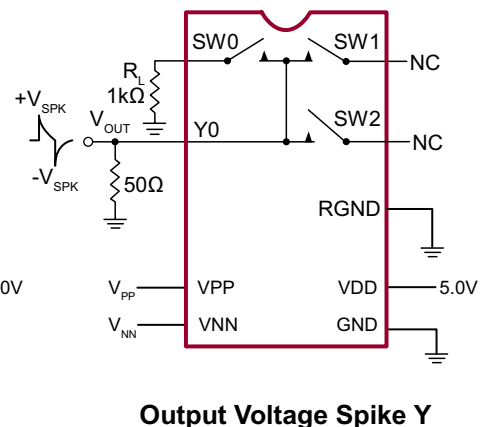
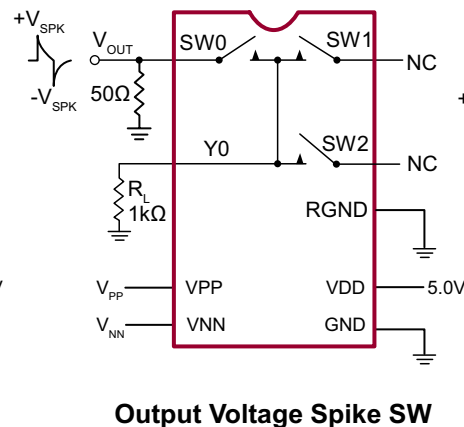
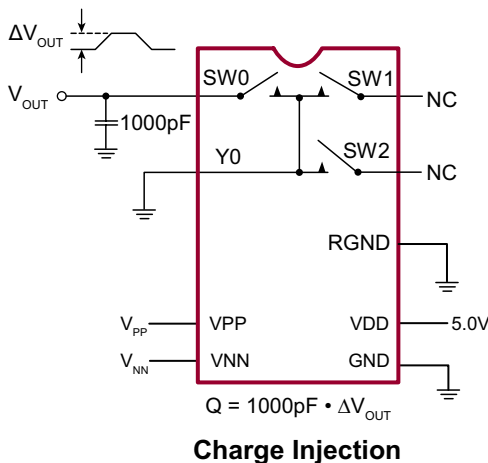
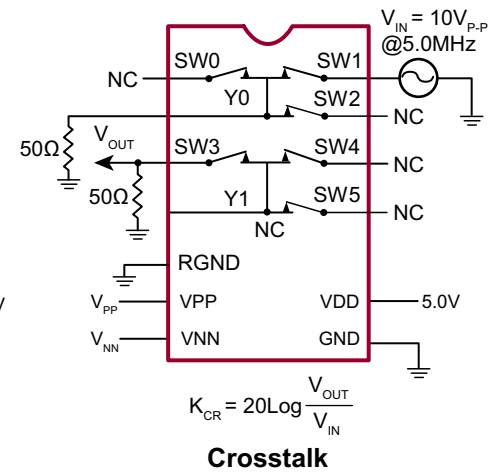
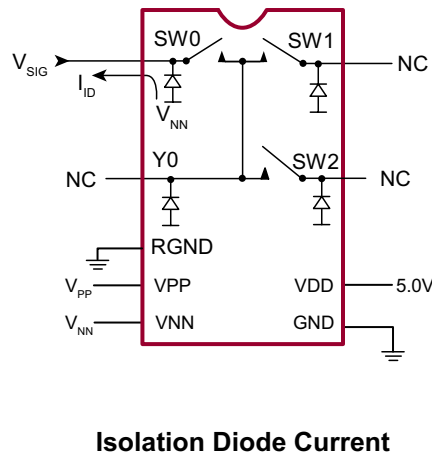
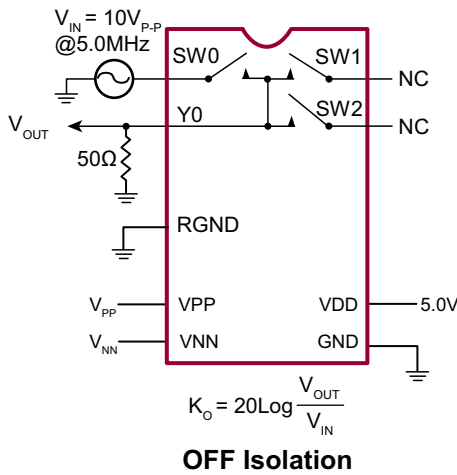
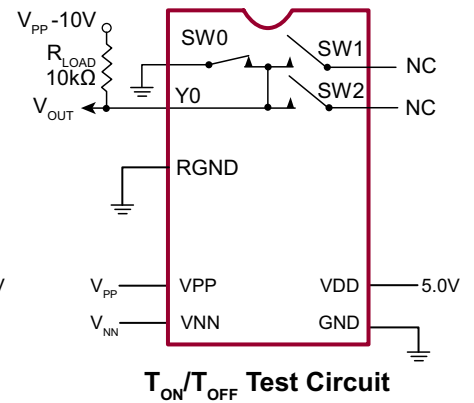
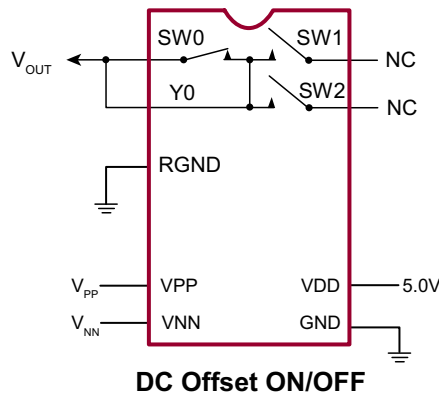
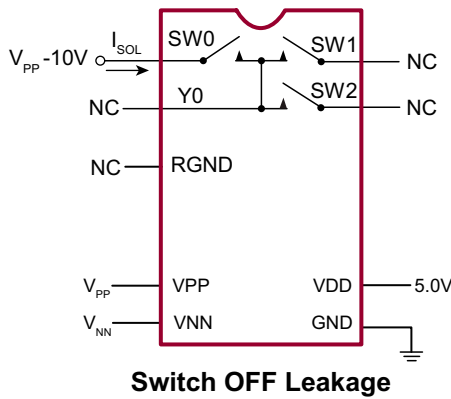

Truth Table

D0	D1	...	D15	D16	...	D23	$\overline{LE}$	CLR	SW0	SW1	...	SW15	SW16	...	SW23
L	-		-	-		-	L	L	OFF	-		-	-		-
H	-		-	-		-	L	L	ON	-		-	-		-
-	L		-	-		-	L	L	-	OFF		-	-		-
-	H		-	-		-	L	L	-	ON		-	-		-
-	-		-	-		-	L	L	-	-		-	-		-
-	-		-	-		-	L	L	-	-		-	-		-
-	-		L	-		-	L	L	-	-		OFF	-		-
-	-		H	-		-	L	L	-	-		ON	-		-
-	-	...	-	L	...	-	L	L	-	-	...	-	OFF	...	-
-	-		-	H		-	L	L	-	-		-	ON		-
-	-		-	-		-	L	L	-	-		-	-		-
-	-		-	-		-	L	L	-	-		-	-		-
-	-		-	-		-	L	L	-	-		-	-		-
-	-		-	-		-	L	L	-	-		-	-		-
-	-		-	-		-	L	L	-	-		-	-		-
-	-		-	-		L	L	L	-	-		-	-		OFF
-	-		-	-		H	L	L	-	-		-	-		ON
X	X	X	X	X	X	X	H	L	HOLD PREVIOUS STATE						
X	X	X	X	X	X	X	X	H	ALL SWITCHES OFF						

Notes:

1. The 24 switches operate independently.
2. Serial data is clocked in on the L to H transition of the CLK.
3. All 24 switches go to a state retaining their latched condition at the rising edge of  $\overline{LE}$ . When  $\overline{LE}$  is low the shift registers data flow through the latch.
4. DOUT is high when data in the register 23 is high.
5. Shift registers clocking has no effect on the switch states if  $\overline{LE}$  is high.
6. The CLR clear input overrides all other inputs.

Logic Timing Waveforms

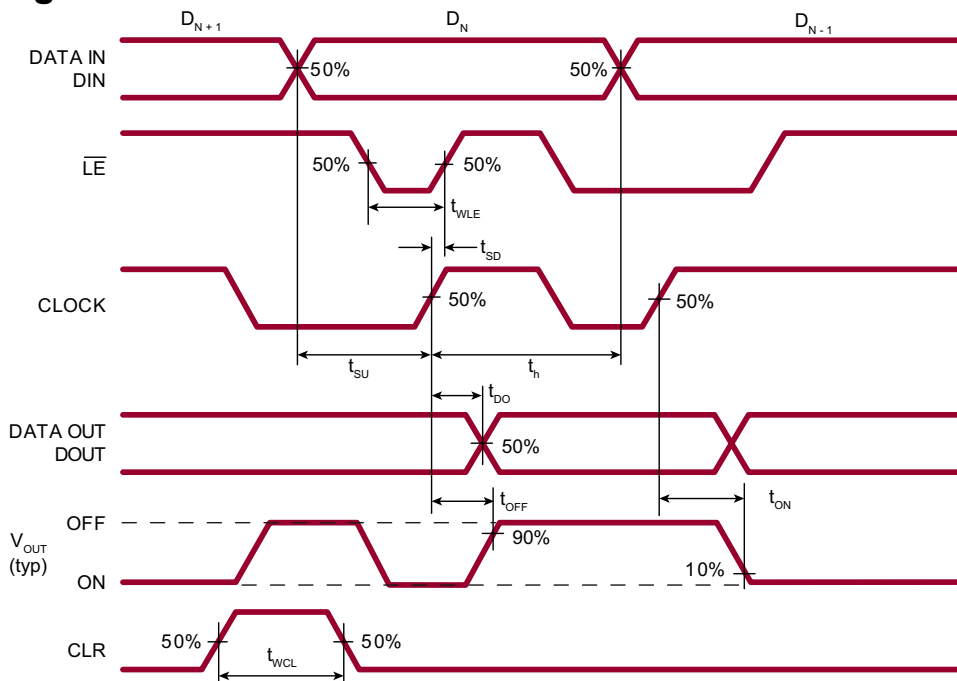

**Pin Function**

Pin	Function
1	VPP
2	NC
3	GND
4	CLR
5	$\overline{LE}$
6	CLK
7	VDD
8	GND
9	DIN
10	DOUT
11	NC
12	VNN

Pin	Function
13	SW0
14	Y0
15	SW1
16	SW2
17	SW3
18	Y1
19	SW4
20	SW5
21	SW6
22	Y2
23	SW7
24	SW8

Pin	Function
25	VPP
26	RGND
27	SW9
28	Y3
29	SW10
30	SW11
31	SW12
32	SW13
33	Y4
34	SW14
35	RGND
36	VNN

Pin	Function
37	SW15
38	SW16
39	Y5
40	SW17
41	SW18
42	SW19
43	Y6
44	SW20
45	SW21
46	SW22
47	Y7
48	SW23

# 48-Lead LQFP Package Outline (FG)

7.00x7.00mm body, 1.60mm height (max), 0.50mm pitch

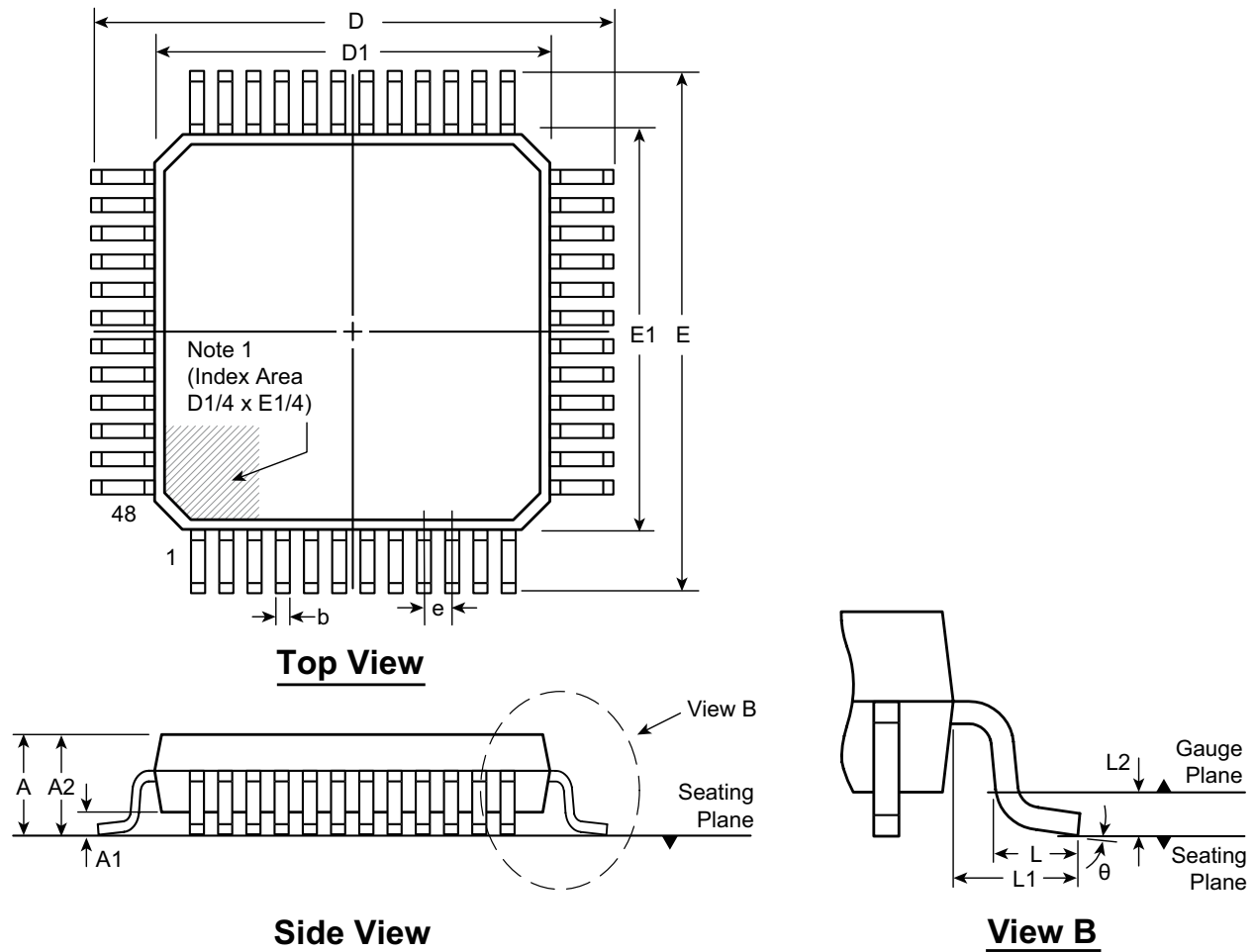

**Note:**  
 1. A Pin 1 identifier must be located in the index area indicated. The Pin 1 identifier can be: a molded mark/identifier; an embedded metal marker; or a printed indicator.

Symbol	A	A1	A2	b	D	D1	E	E1	e	L	L1	L2	θ
Dimension (mm)	MIN	1.40*	0.05	1.35	0.17	8.80*	6.80*	8.80*	6.80*	0.50 BSC	1.00 REF	0.25 BSC	0°
	NOM	-	-	1.40	0.22	9.00	7.00	9.00	7.00				3.5°
	MAX	1.60	0.15	1.45	0.27	9.20*	7.20*	9.20*	7.20*				7°

JEDEC Registration MS-026, Variation BBC, Issue D, Jan. 2001.  
 \* This dimension is not specified in the JEDEC drawing.

**Drawings are not to scale.**  
**Supertex Doc. #: DSPD-48LQFPFG Version, D041309.**

(The package drawing(s) in this data sheet may not reflect the most current specifications. For the latest package outline information go to <http://www.supertex.com/packaging.html>.)

**Supertex inc.** does not recommend the use of its products in life support applications, and will not knowingly sell them for use in such applications unless it receives an adequate "product liability indemnification insurance agreement." **Supertex inc.** does not assume responsibility for use of devices described, and limits its liability to the replacement of the devices determined defective due to workmanship. No responsibility is assumed for possible omissions and inaccuracies. Circuitry and specifications are subject to change without notice. For the latest product specifications refer to the **Supertex inc.** (website: <http://www.supertex.com>)