

## Low Noise, High Voltage EL Lamp Driver IC

### Features

- ▶ Audible noise reduction
- ▶ 190 V<sub>PP</sub> output voltage for higher brightness
- ▶ Single cell lithium ion compatible
- ▶ 150nA shutdown current
- ▶ Wide input voltage range 1.8V to 5.0V
- ▶ Separately adjustable lamp and converter frequencies
- ▶ Output voltage regulation
- ▶ Split supply capability
- ▶ Available in 8-Lead DFN (K7) and 8-Lead MSOP (MG) packages

### Applications

- ▶ Mobile cellular phones
- ▶ Keypad backlighting
- ▶ LCD backlighting
- ▶ PDAs
- ▶ Handheld wireless communication products
- ▶ Global Positioning Systems (GPS)

### General Description

The Supertex HV857L is a low noise, high voltage driver designed for driving Electroluminescent (EL) lamps of up to five square inches. It is the low noise version of the EL lamp driver HV857. The input supply voltage range is from 1.8V to 5.0V. The device uses a single inductor and a minimum number of passive components. The nominal regulated output voltage that is applied to the EL lamp is  $\pm 95V$ . The chip can be enabled/disabled by connecting the resistor on RSW-Osc to VDD/ground.

The HV857L has two internal oscillators, a switching MOSFET, and a high voltage EL lamp driver. The frequency for the switching MOSFET is set by an external resistor connected between the RSW-Osc pin and the supply pin, VDD. The EL lamp driver frequency is set by an external resistor connected between the REL-Osc and VDD pins. An external inductor is connected between the LX and VDD pins, or VIN for split supply applications. A 0.003-0.1 $\mu$ F capacitor is connected between CS and ground. The EL lamp is connected between the VA and VB pins.

The switching MOSFET charges the external inductor and discharges it into the capacitor at CS. The voltage at CS will start to increase. Once the voltage at CS reaches a nominal value of 95V, the switching MOSFET is turned OFF to conserve power. The outputs VA and VB are configured as an H bridge, and are switching in opposite states to achieve  $\pm 95V$  across the EL lamp.

### Typical Application Circuit

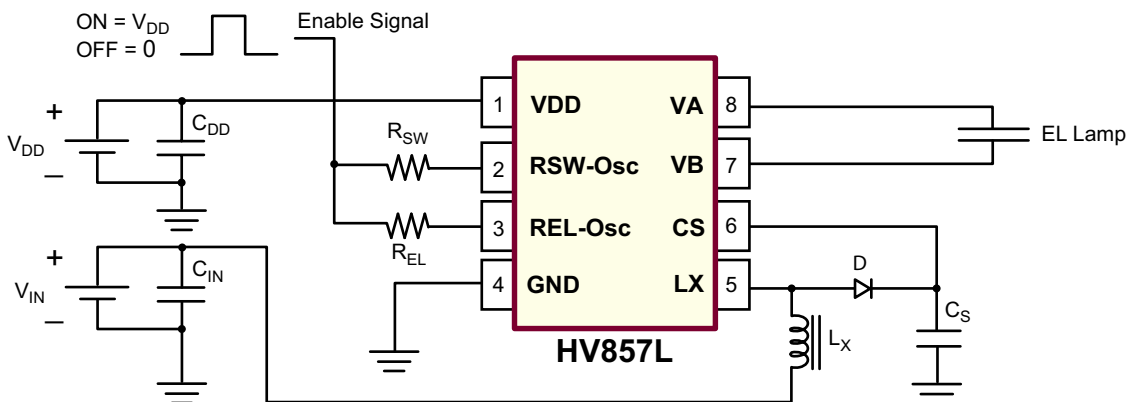

## Ordering Information

Device	Package Options	
	8-Lead DFN 3.00x3.00mm body 0.80mm height (max) 0.65mm pitch	8-Lead MSOP 3.00x3.00mm body 1.10mm height (max) 0.65mm pitch
HV857L	HV857LK7-G	HV857LMG-G

-G indicates package is RoHS compliant ('Green')



## Pin Configurations

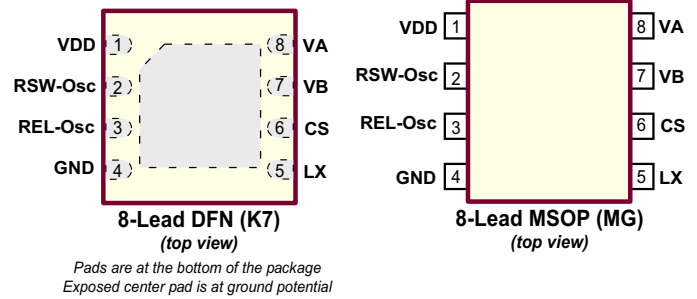

## Absolute Maximum Ratings

Parameter	Value
Supply voltage, $V_{DD}$	-0.5V to 6.5V
Operating temperature	-40°C to +85°C
Storage temperature	-65°C to +150°C
8-Lead DFN power dissipation	1.6W
8-Lead MSOP power dissipation	300mW
Output voltage, $V_{CS}$	-0.5 to +120V

Absolute Maximum Ratings are those values beyond which damage to the device may occur. Functional operation under these conditions is not implied. Continuous operation of the device at the absolute rating level may affect device reliability. All voltages are referenced to device ground.

## Thermal Resistance

Package	$\theta_{ja}$
8-Lead DFN (K7)	60°C/W
8-Lead MSOP (MG)	330°C/W

Mounted on FR4 board, 25mm x 25mm x 1.57mm

## Recommended Operating Conditions

Sym	Parameter	Min	Typ	Max	Units	Conditions
$V_{DD}$	Supply voltage	1.8	-	5.0	V	---
$f_{EL}$	Operating drive frequency	-	-	1	kHz	---
$T_A$	Operating temperature	-40	-	+85	°C	---

## Product Marking

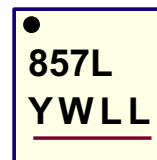

Y = Last Digit of Year Sealed  
W = Code for Week Sealed  
L = Lot Number  
— = "Green" Packaging

### 8-Lead DFN (K7)

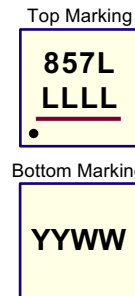

L = Lot Number  
YY = Year Sealed  
WW = Week Sealed  
— = "Green" Packaging

### 8-Lead MSOP (MG)

## Electrical Characteristics

**DC Characteristics** (Over recommended operating conditions unless otherwise specified,  $T_A = 25^\circ\text{C}$ )

Sym	Parameter	Min	Typ	Max	Units	Conditions
$R_{DS(ON)}$	On-resistance of switching transistor	-	-	6.0	$\Omega$	$I = 100\text{mA}$
$V_{CS}$	Max. output regulation voltage	85	95	105	V	$V_{DD} = 1.8 \text{ to } 5.0\text{V}$
$V_A - V_B$	Peak to peak output voltage	170	190	210	V	$V_{DD} = 1.8 \text{ to } 5.0\text{V}$
$I_{DDQ}$	Quiescent $V_{DD}$ supply current	-	-	150	nA	$R_{SW-Osc} = \text{Low}$
$I_{DD}$	Input current going into the VDD pin	-	-	150	$\mu\text{A}$	$V_{DD} = 1.8 \text{ to } 5.0\text{V}$ . See Fig. 1
$I_{IN}$	Input current including inductor current	-	25	40	mA	See Fig. 1*
$V_{CS}$	Output voltage on VCS	-	92	-	V	See Fig. 1
$f_{EL}$	EL lamp frequency	175	205	235	Hz	See Fig. 1
$f_{SW}$	Switching transistor frequency	65	77	89	kHz	See Fig. 1
D	Switching transistor duty cycle	-	88	-	%	See Fig. 1

\* The inductor used is a 220 $\mu\text{H}$  Murata inductor, max DC resistance of 8.4 $\Omega$ , part # LQH32CN221K21.

## Enable/Disable Function Table

Sym	Parameter	Min	Typ	Max	Units	Conditions
EN-L	Logic input low voltage	0	-	0.2	V	$V_{DD} = 1.8 \text{ to } 5.0\text{V}$
EN-H	Logic input high voltage	$V_{DD} - 0.2$	-	$V_{DD}$	V	$V_{DD} = 1.8 \text{ to } 5.0\text{V}$

## Block Diagram

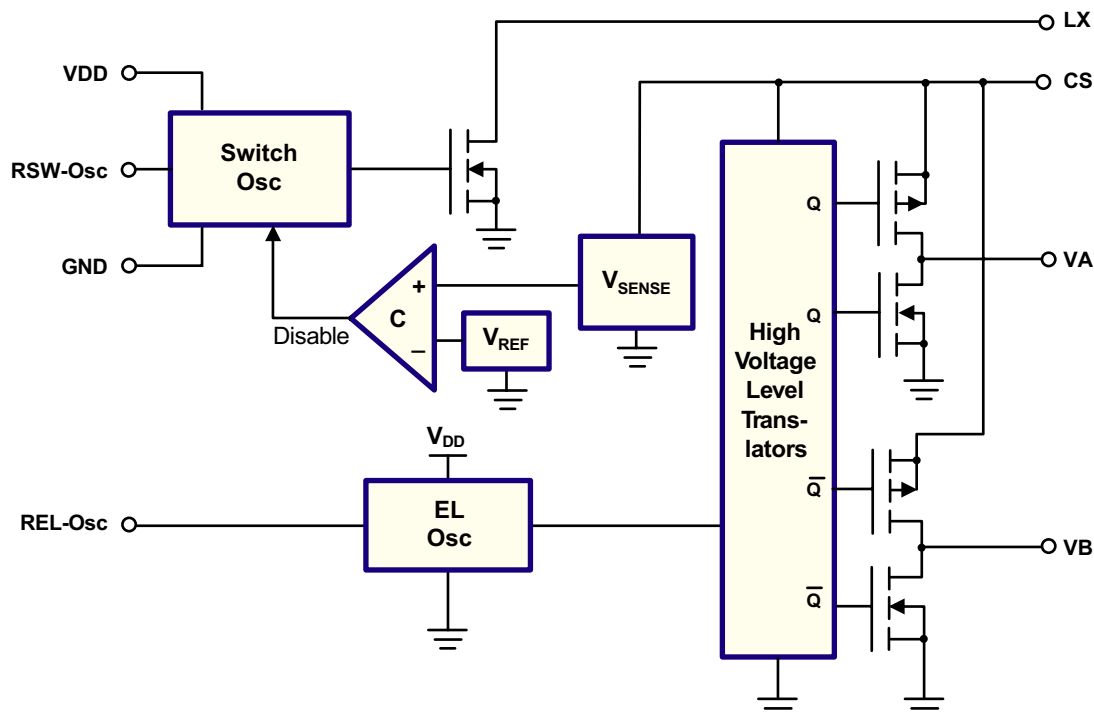

## Fig. 1: Typical Application/ Test Circuit

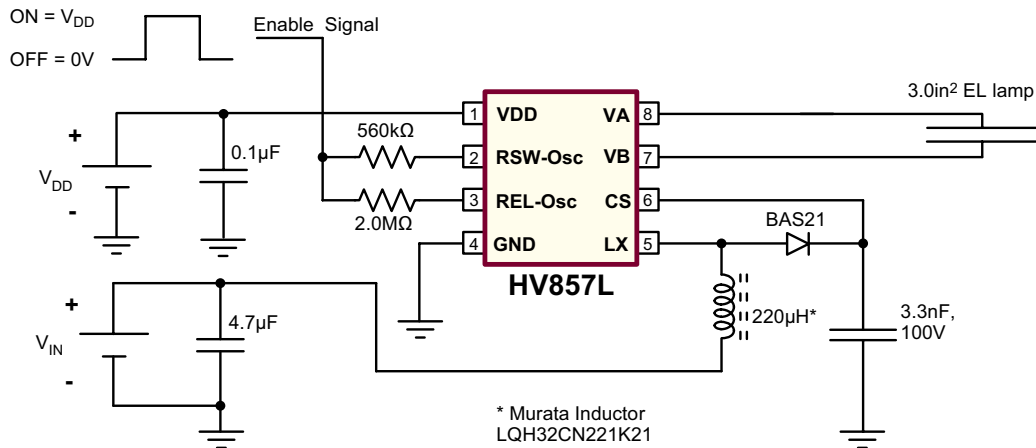

## Typical Performance

Device	Lamp Size	$V_{DD} = V_{IN}$	$I_{IN}$	$V_{CS}$	$f_{EL}$	Brightness
HV857LMG-G	3.0in <sup>2</sup>	3.3V	25.40mA	92V	205Hz	5.70ft-Im

## Typical Performance Curves for Fig. 1 (EL Lamp = 3.0in<sup>2</sup>, $V_{DD} = 3.0V$ )

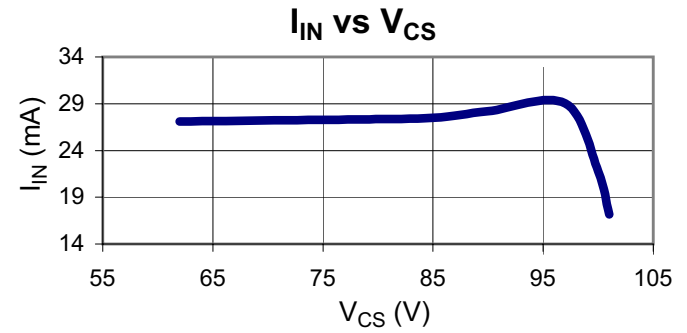
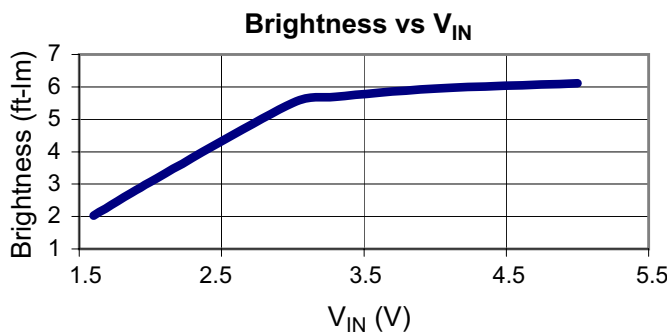
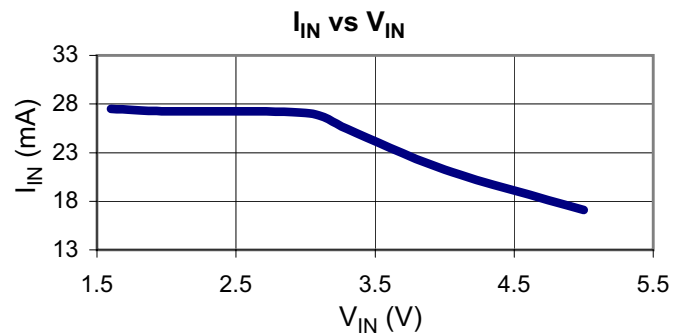
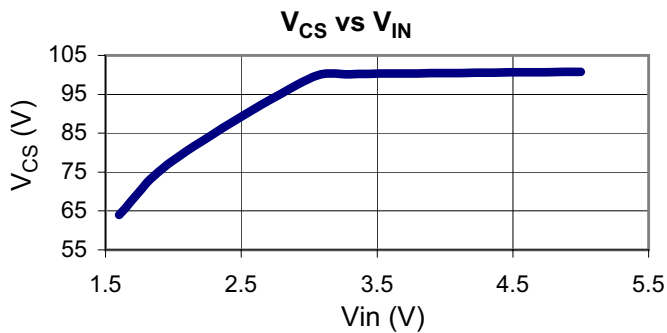

Typical Waveform on  $V_A$ ,  $V_B$  and Differential Waveform  $V_A - V_B$

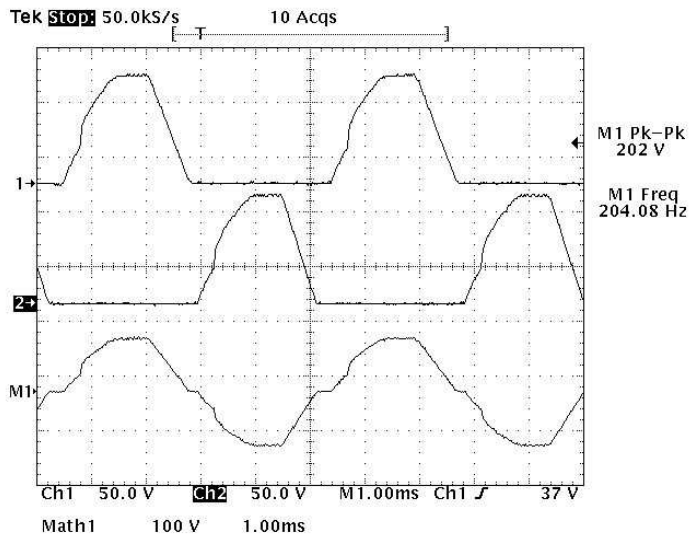
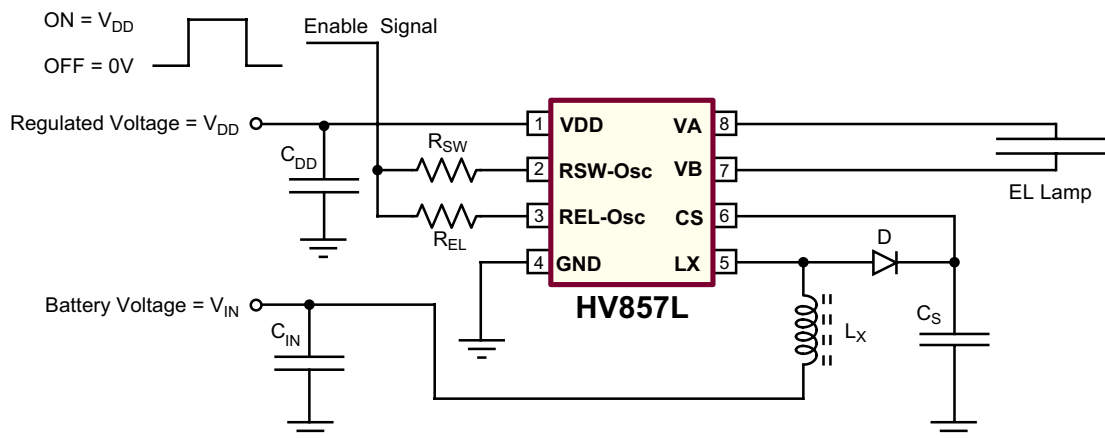

Fig. 2: Split Supply and Enable/Disable Configuration



Split Supply Configuration

The HV857L can also be used for handheld devices operating from a battery where a regulated voltage is available. This is shown in Fig. 2. The regulated voltage can be used to run the internal logic of the HV857L. The amount of current necessary to run the internal logic is 150 $\mu$ A maximum at a  $V_{DD}$  of 5.0V. Therefore, the regulated voltage could easily provide the current without being loaded down.

Enable/Disable Configuration

The HV857L can be easily enabled and disabled via a logic control signal on the  $R_{SW}$  and  $R_{EL}$  resistors as shown in Fig. 2 below. The control signal, which can be from a microprocessor, has to track the  $V_{DD}$  supply.  $R_{SW}$  and  $R_{EL}$  are typically very high values. Therefore, only 10's of microamperes will be drawn from the logic signal when it is at a logic high (enable) state. When the microprocessor signal is high, the device is enabled, and when the signal is low, it is disabled.

Audible Noise Reduction

The EL lamp, when lit, emits an audible noise. This is due to EL lamp construction and it creates a major problem for applications where the EL lamp can be close to the ear such as cellular phones. The HV857L employs a circuit designed to help minimize the EL lamp's audible noise by slowing down the rise and fall times seen by the EL lamp.

External Component	Description
Diode	Fast reverse recovery diode, BAS21 diode or equivalent.
$C_s$ Capacitor	0.003 $\mu$ F to 0.1 $\mu$ F, 100V capacitor to GND is used to store the energy transferred from the inductor.
$R_{EL}$ Resistor	<p>The EL lamp frequency is controlled via an external <math>R_{EL}</math> resistor connected between REL-Osc and VDD of the device. The lamp frequency increases as <math>R_{EL}</math> decreases. As the EL lamp frequency increases, the amount of current drawn from the battery will increase and the output voltage <math>V_{CS}</math> will decrease. The color of the EL lamp is dependent upon its frequency.</p> <p>A 2M<math>\Omega</math> resistor would provide lamp frequency of 205Hz. Decreasing the <math>R_{EL}</math> resistor by a factor of 2 will increase the lamp frequency by a factor of 2.</p> $f_{EL} = \frac{(2M\Omega)(205Hz)}{R_{EL}}$
$R_{SW}$ Resistor	<p>The switching frequency of the converter is controlled via an external resistor, <math>R_{SW}</math>, between RSW-Osc and VDD of the device. The switching frequency increases as <math>R_{SW}</math> decreases. With a given inductor, as the switching frequency increases, the amount of current drawn from the battery will decrease and the output voltage, <math>V_{CS}</math>, will also decrease.</p> $f_{SW} = \frac{(560k\Omega)(77kHz)}{R_{SW}}$
$L_x$ Inductor	<p>The inductor <math>L_x</math> is used to boost the low input voltage by inductive flyback. When the internal switch is on, the inductor is being charged. When the internal switch is off, the charge stored in the inductor will be transferred to the high voltage capacitor <math>C_s</math>. The energy stored in the capacitor is connected to the internal H-bridge, and therefore to the EL lamp. In general, smaller value inductors, which can handle more current, are more suitable to drive larger size lamps. As the inductor value decreases, the switching frequency of the inductor (controlled by <math>R_{SW}</math>) should be increased to avoid saturation.</p> <p>A 220<math>\mu</math>H Murata (LQH32CN221) inductor with 8.4<math>\Omega</math> series DC resistance is typically recommended. For inductors with the same inductance value, but with lower series DC resistance, a lower <math>R_{SW}</math> resistor value is needed to prevent high current draw and inductor saturation.</p>
Lamp	As the EL lamp size increases, more current will be drawn from the battery to maintain high voltage across the EL lamp. The input power, ( $V_{IN} \times I_{IN}$ ), will also increase. If the input power is greater than the power dissipation of the package, an external resistor in series with one side of the lamp is recommended to help reduce the package power dissipation.

# 8-Lead DFN Package Outline (K7)

3.00x3.00mm body, 0.80mm height (max), 0.65mm pitch

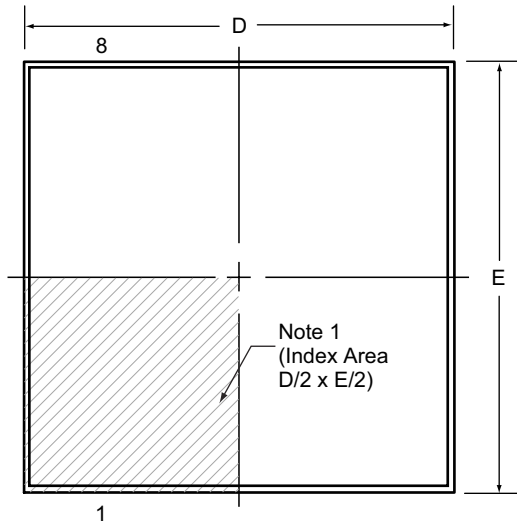

**Top View**

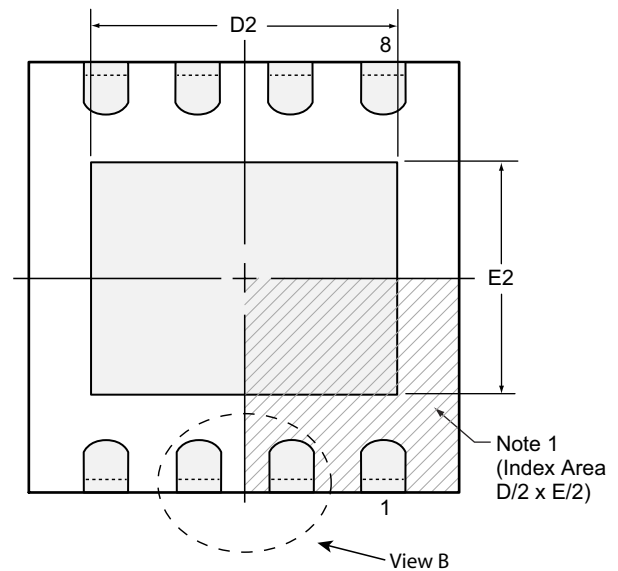

**Bottom View**

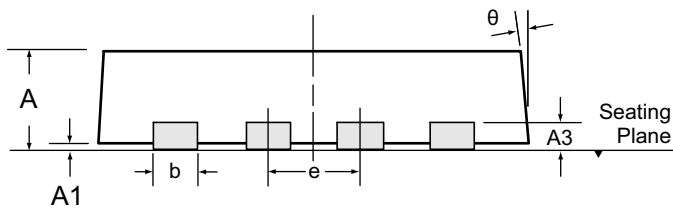

**Side View**

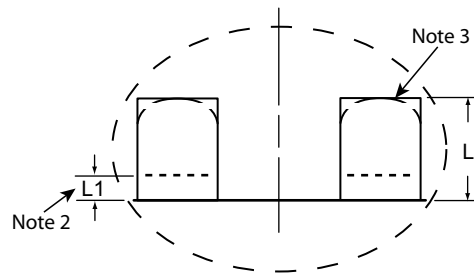

**View B**

**Notes:**

1. A Pin 1 identifier must be located in the index area indicated. The Pin 1 identifier can be: a molded mark/identifier; an embedded metal marker; or a printed indicator.
2. Depending on the method of manufacturing, a maximum of 0.15mm pullback (L1) may be present.
3. The inner tip of the lead may be either rounded or square.

Symbol		A	A1	A3	b	D	D2	E	E2	e	L	L1	θ
Dimension (mm)	MIN	0.70	0.00	0.20 REF	0.25	2.85*	1.60	2.85*	1.35	0.65 BSC	0.30	0.00	0°
	NOM	0.75	0.02		0.30	3.00	-	3.00	-		0.40	-	-
	MAX	0.80	0.05		0.35	3.15*	2.50	3.15*	1.75		0.50	0.15	14°

JEDEC Registration MO-229, Variation WEEC-2, Issue C, Aug. 2003.

\* This dimension is not specified in the original JEDEC drawing. The value listed is for reference only.

Drawings not to scale.

Supertex Doc. #: DSPD-8DFNK73X3P065, Version B101008.

# 8-Lead MSOP Package Outline (MG)

3.00x3.00mm body, 1.10mm height (max), 0.65mm pitch

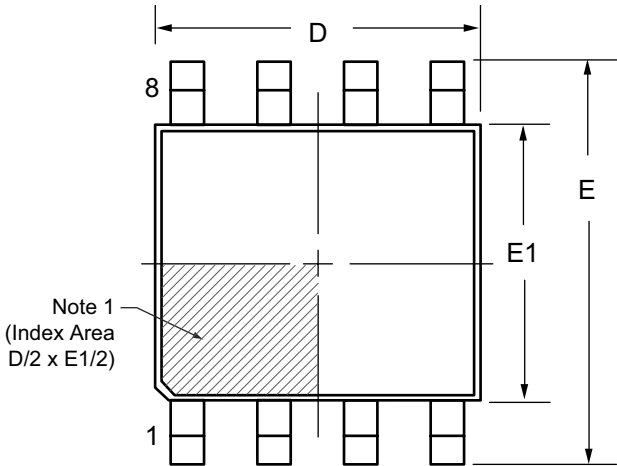

**Top View**

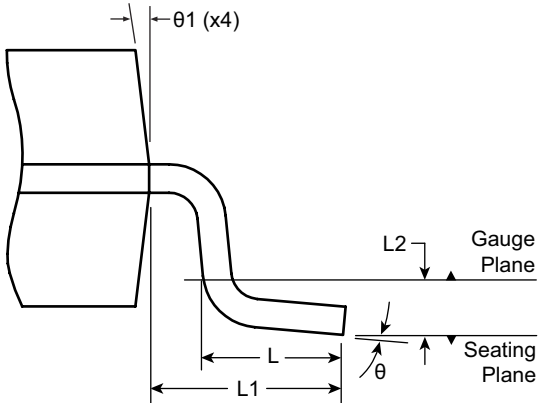

**View B**

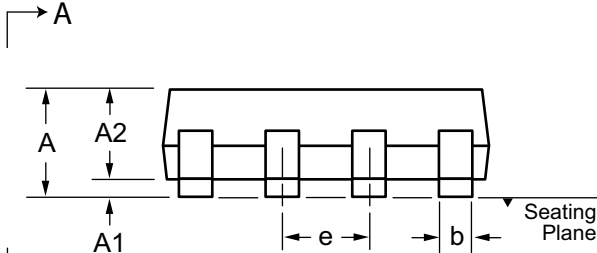

**Side View**

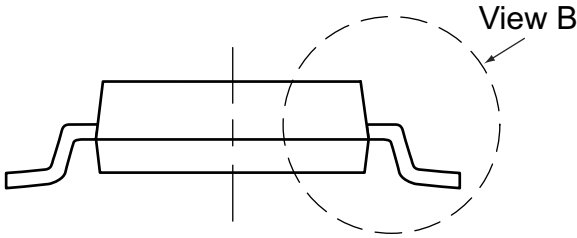

**View A-A**

**Note:**  
 1. A Pin 1 identifier must be located in the index area indicated. The Pin 1 identifier can be: a molded mark/identifier; an embedded metal marker; or a printed indicator.

Symbol	A	A1	A2	b	D	E	E1	e	L	L1	L2	θ	θ1	
Dimension (mm)	MIN	0.75*	0.00	0.75	0.22	2.80*	4.65*	2.80*	0.65 BSC	0.40	0.95 REF	0.25 BSC	0°	5°
	NOM	-	-	0.85	-	3.00	4.90	3.00		0.60		0.25 BSC	-	-
	MAX	1.10	0.15	0.95	0.38	3.20*	5.15*	3.20*		0.80		0.25 BSC	8°	15°

JEDEC Registration MO-187, Variation AA, Issue E, Dec. 2004.  
 \* This dimension is not specified in the original JEDEC drawing. The value listed is for reference only.  
**Drawings are not to scale.**  
**Supertex Doc. #: DSPD-8MSOPMG, Version G101008.**

(The package drawing(s) in this data sheet may not reflect the most current specifications. For the latest package outline information go to <http://www.supertex.com/packaging.html>.)

Supertex inc. does not recommend the use of its products in life support applications, and will not knowingly sell them for use in such applications unless it receives an adequate "product liability indemnification insurance agreement." Supertex inc. does not assume responsibility for use of devices described, and limits its liability to the replacement of the devices determined defective due to workmanship. No responsibility is assumed for possible omissions and inaccuracies. Circuitry and specifications are subject to change without notice. For the latest product specifications refer to the Supertex inc. website: <http://www.supertex.com>.