

Simple, 220V, 20mA, Temperature-Compensated, Constant Current, LED Driver IC

Features

- ▶ 5.0 to 220V operating range (V_{A-B})
- ▶ 20mA $\pm 10\%$ at 5.0 - 160V
- ▶ 0.01% / °C typical temperature coefficient
- ▶ Available in TO-252 (D-PAK) and TO-220 packages
- ▶ Can be paralleled for higher current

Applications

- ▶ Industrial lamp indicators
- ▶ Signage
- ▶ Accent lighting
- ▶ Constant current source
- ▶ Constant current sink

General Description

The Supertex CL220 is a high voltage, temperature-compensated, 20mA constant current regulator. The device operates at up to 220V, and is accurate to $\pm 10\%$ over a 5.0 - 160V range. The device can be used as a two terminal constant current source or constant current sink.

A typical application for the CL220 is to drive LEDs with a constant current of 20mA. Multiple CL220s can also be used in parallel to provide higher currents such as 40mA, 60mA, 80mA, and so on. The device is available in the TO-252 (D-PAK) and TO-220 packages.

Typical Application Circuit

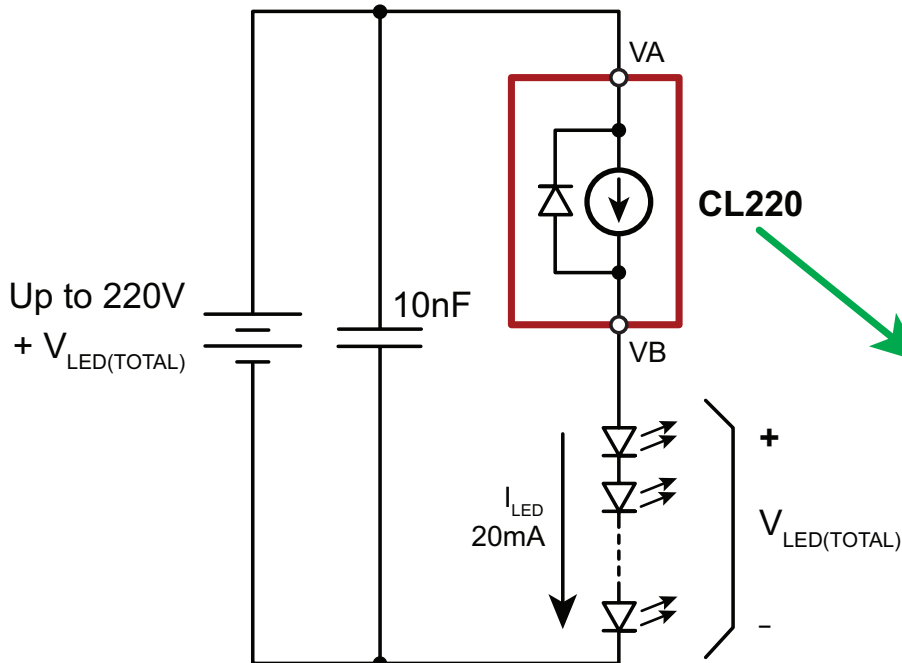

Functional Circuit Diagram

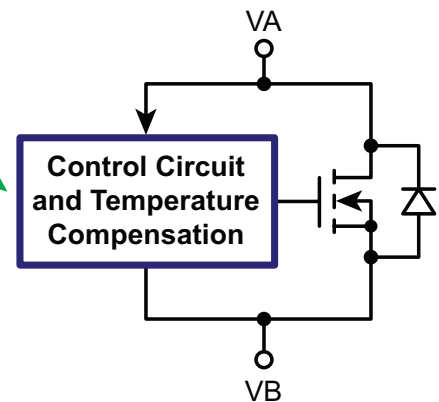

Ordering Information

Device	Package Options	
	TO-252 (D-PAK)	TO-220
CL220	CL220K4-G	CL220N5-G

-G indicates package is RoHS compliant ('Green')



ESD Sensitive Device

Pin Configurations

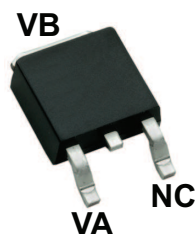

TO-252 (D-PAK)
(front view)

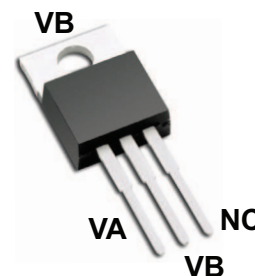

TO-220
(front view)

Absolute Maximum Ratings

Parameter	Value
Operating voltage, V_{A-B}	240V
Operating junction temperature, T_j	-40°C to +125°C
Storage temperature, T_s	-55°C to +150°C

Absolute Maximum Ratings are those values beyond which damage to the device may occur. Functional operation under these conditions is not implied. Continuous operation of the device at the absolute rating level may affect device reliability. All voltages are referenced to device ground.

Product Marking

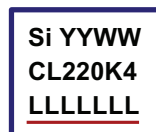

YY = Year Sealed
WW = Week Sealed
L = Lot Number
— = "Green" Packaging

Packages may or may not include the following marks: Si or

TO-252 (D-PAK)



L = Lot Number
YY = Year Sealed
WW = Week Sealed
— = "Green" Packaging

Packages may or may not include the following marks: Si or

TO-220

Pin Designation

Pin	Description
VA	Current flows into this pin.
VB	Current flows out of this pin.

Thermal Characteristics *Guaranteed by design – not production tested*

Sym	Parameter	Min	Typ	Max	Units	Conditions	
θ_{jc}	Thermal resistance, junction to case	TO-252 (D-PAK)	-	6.3	-	°C/W	---
		TO-220	-	8.3	-		
θ_{ja}	Thermal resistance, junction to ambient	TO-252 (D-PAK)	-	78	-	°C/W	Soldered to 2.0cm ² exposed copper free air area
		TO-220	-	70	-		

Electrical Characteristics ($T_j = 25^\circ\text{C}$ unless otherwise specified)

Sym	Parameter	Min	Typ	Max	Units	Conditions
V_{A-B}	Operating voltage	5.0	-	220	V	---
$\Delta I_{A-B}/\Delta T$	I_{A-B} temperature coefficient	-	0.01	-	%/ $^\circ\text{C}$	$V_{A-B} = 45\text{V}$, $T_j = -40^\circ\text{C}$ to $+100^\circ\text{C}$
R_{A-B}	Dynamic resistance	-	300	-	k Ω	---
I_{AB}	Output current	18	20	22	mA	$V_{AB} = 4.0 - 160\text{V}$
		18	-	25		$V_{AB} = 160 - 220\text{V}$ (Fig. 4)
		-	-	22		$V_{AB} = 0 - 4.0\text{V}$
I_{OS}	Turn-on overshoot current	-	25	-	mA	$V_T = 45\text{V}$ (Fig. 5)
t_{OS}	Overshoot duration	-	1	-	μs	$V_T = 45\text{V}$ (Fig. 5)
t_{DLY}	Turn-on delay	-	10	-	μs	$V_T = 45\text{V}$ (Fig. 5)
t_{RISE}	Turn-on rise time	-	200	-	ns	$V_T = 45\text{V}$ (Fig. 5)

Fig. 1 Functional Circuit Diagram

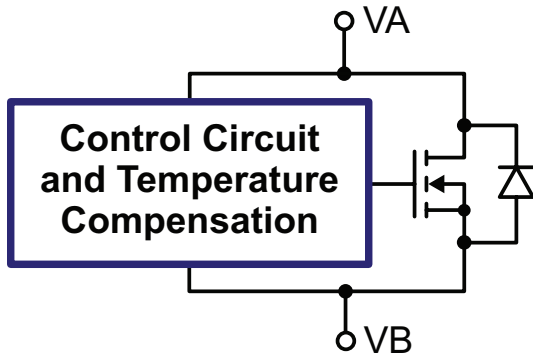

Fig. 2 Equivalent Block Diagram

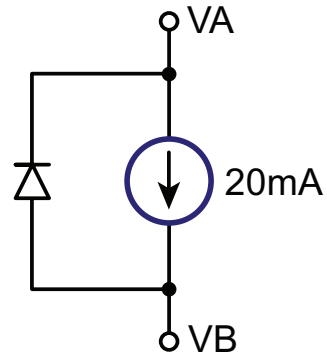

Fig. 3 Temperature Characteristics

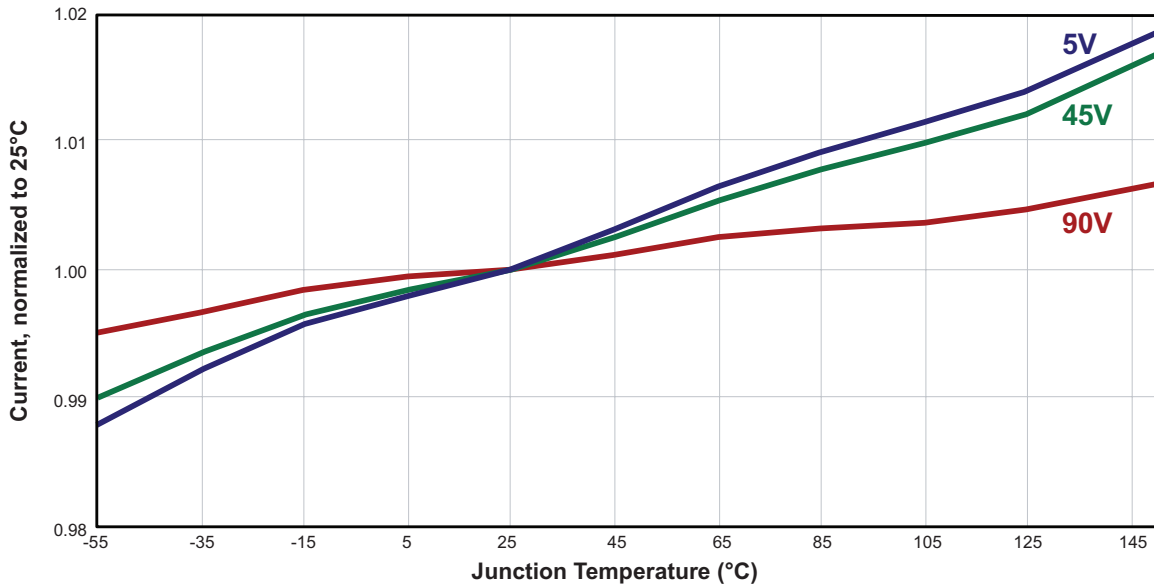

Fig. 4 Output Characteristics

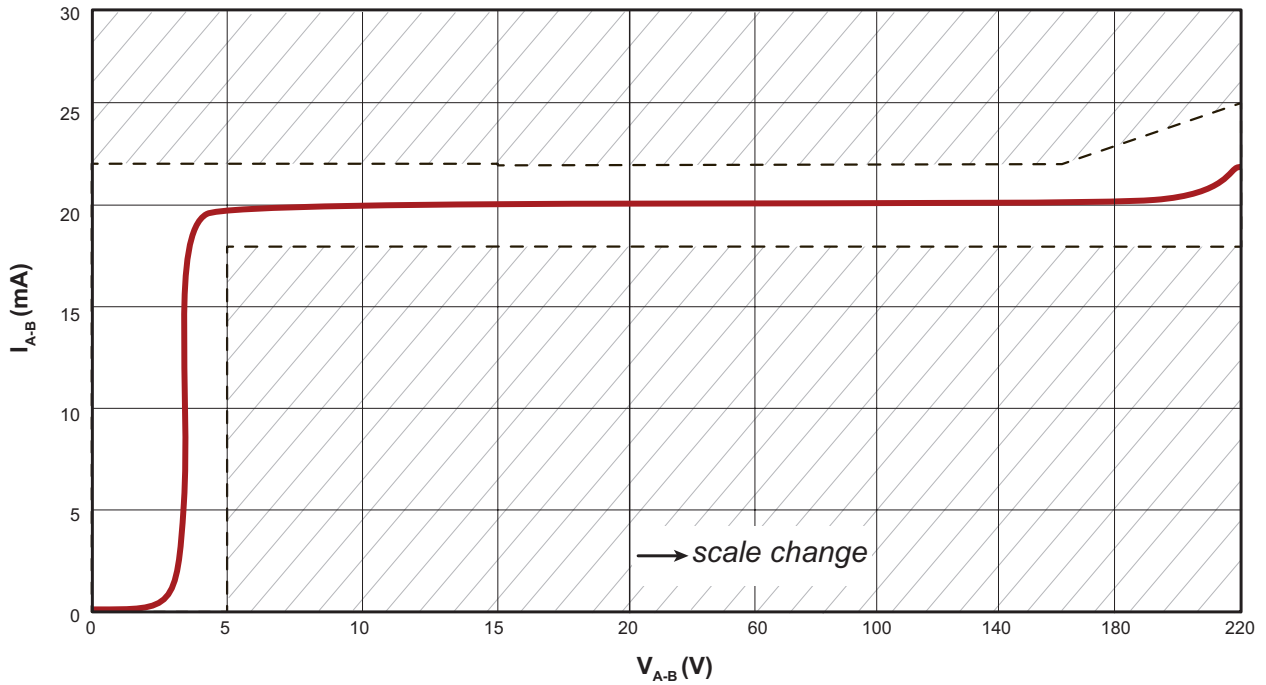

Fig. 5 Timing Diagram

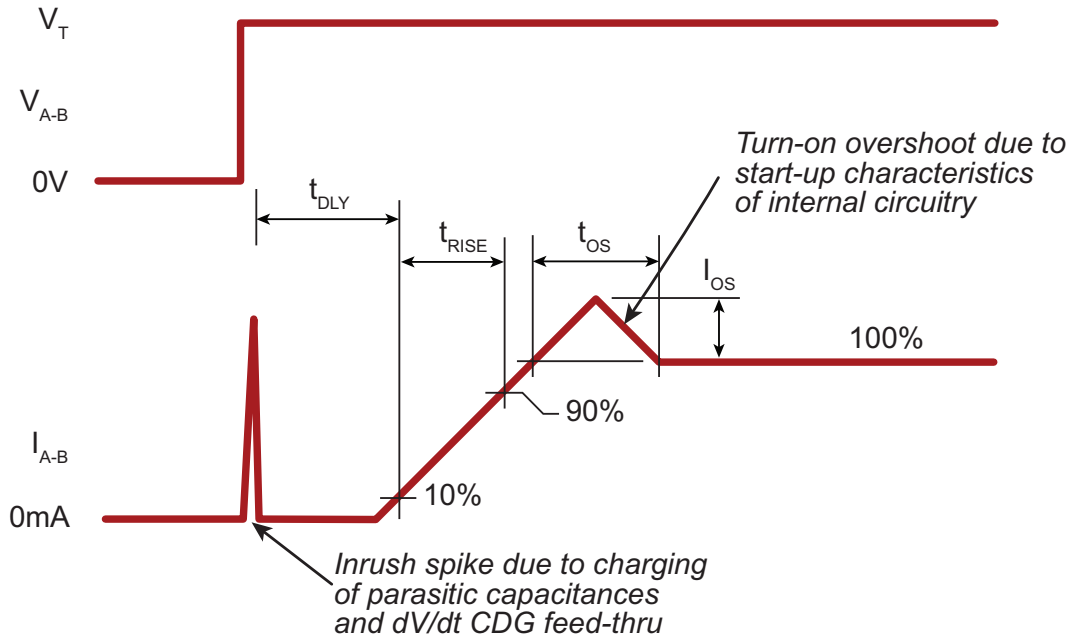

Fig. 6 Timing Test Circuit

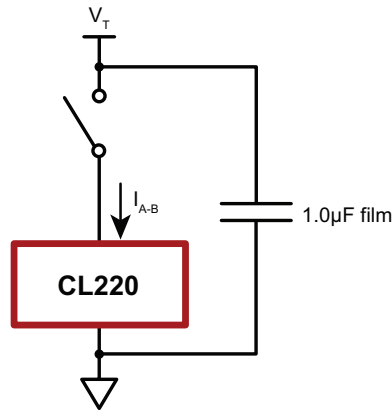

Fig. 7 CL220 for Multiple LED Strings

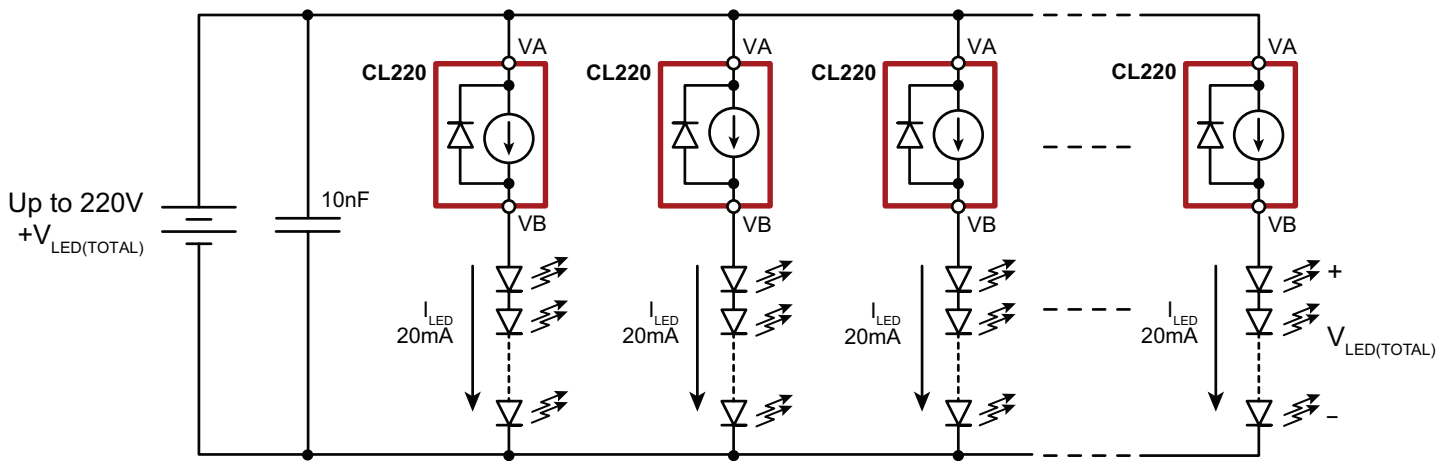
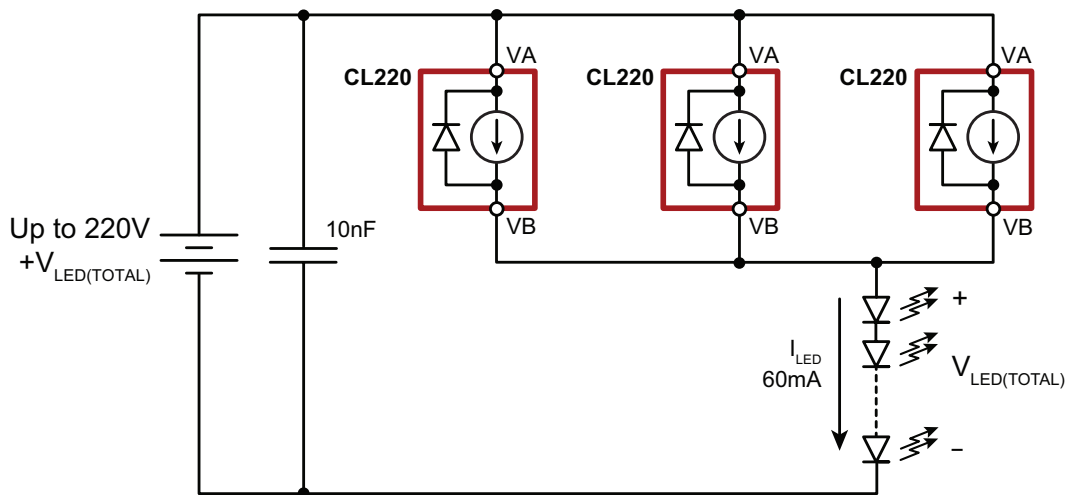
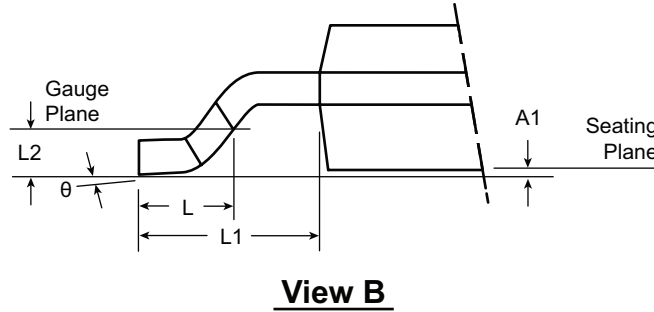
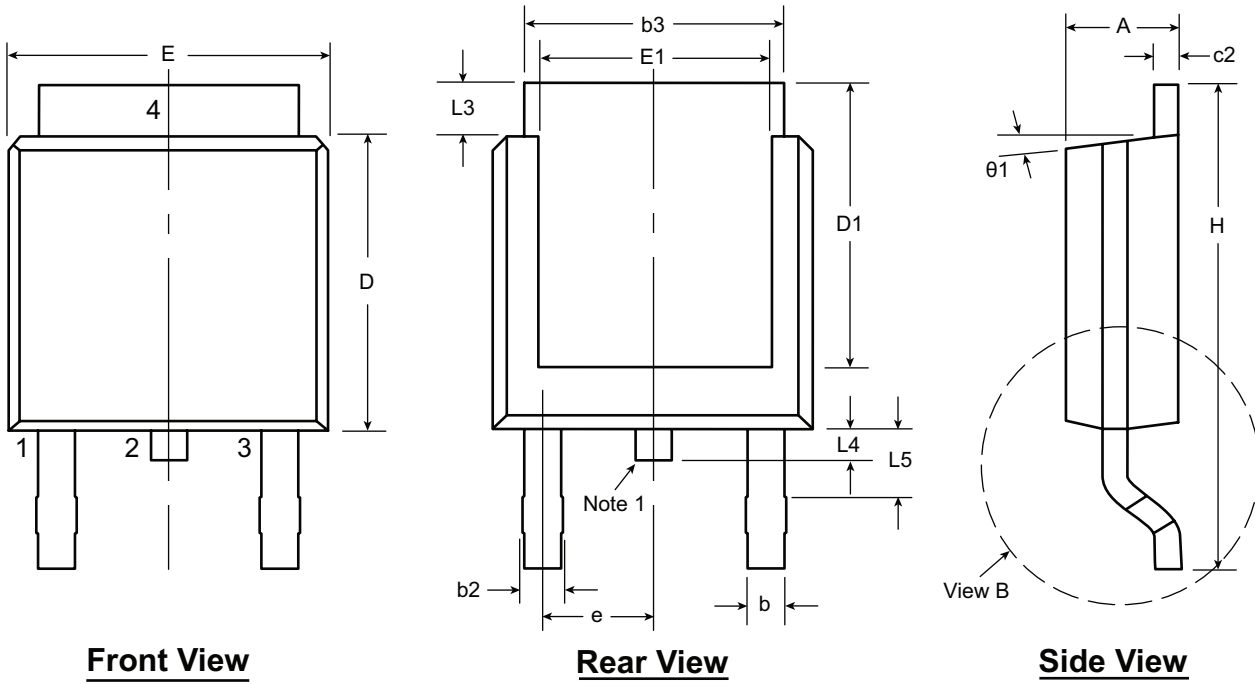

Fig. 8 CL220 for Higher Current



3-Lead TO-252 (D-PAK) Package Outline (K4)



Note:
 1. Although 4 terminal locations are shown, only 3 are functional. Lead number 2 was removed.

Symbol	A	A1	b	b2	b3	c2	D	D1	E	E1	e	H	L	L1	L2	L3	L4	L5	θ	θ1			
Dimension (inches)	MIN	.086	.000*	.025	.030	.195	.018	.235	.205	.250	.170	.090 BSC	.370	.055	.108 REF	.020 BSC	.035	.025*	.035†	0°	0°		
	NOM	-	-	-	-	-	-	.240	-	-	-		-	.060			-	-	-	-	-	-	-
	MAX	.094	.005	.035	.045	.215	.035	.245	.217*	.265	.200*		.410	.070			.050	.040	.060	10°	15°		

JEDEC Registration TO-252, Variation AA, Issue E, June 2004.

* This dimension is not specified in the JEDEC drawing.

† This dimension differs from the JEDEC drawing.

Drawings not to scale.

Supertex Doc. #: DSPD-3TO252K4, Version F040910.

3-Lead TO-220 Package Outline (N5)

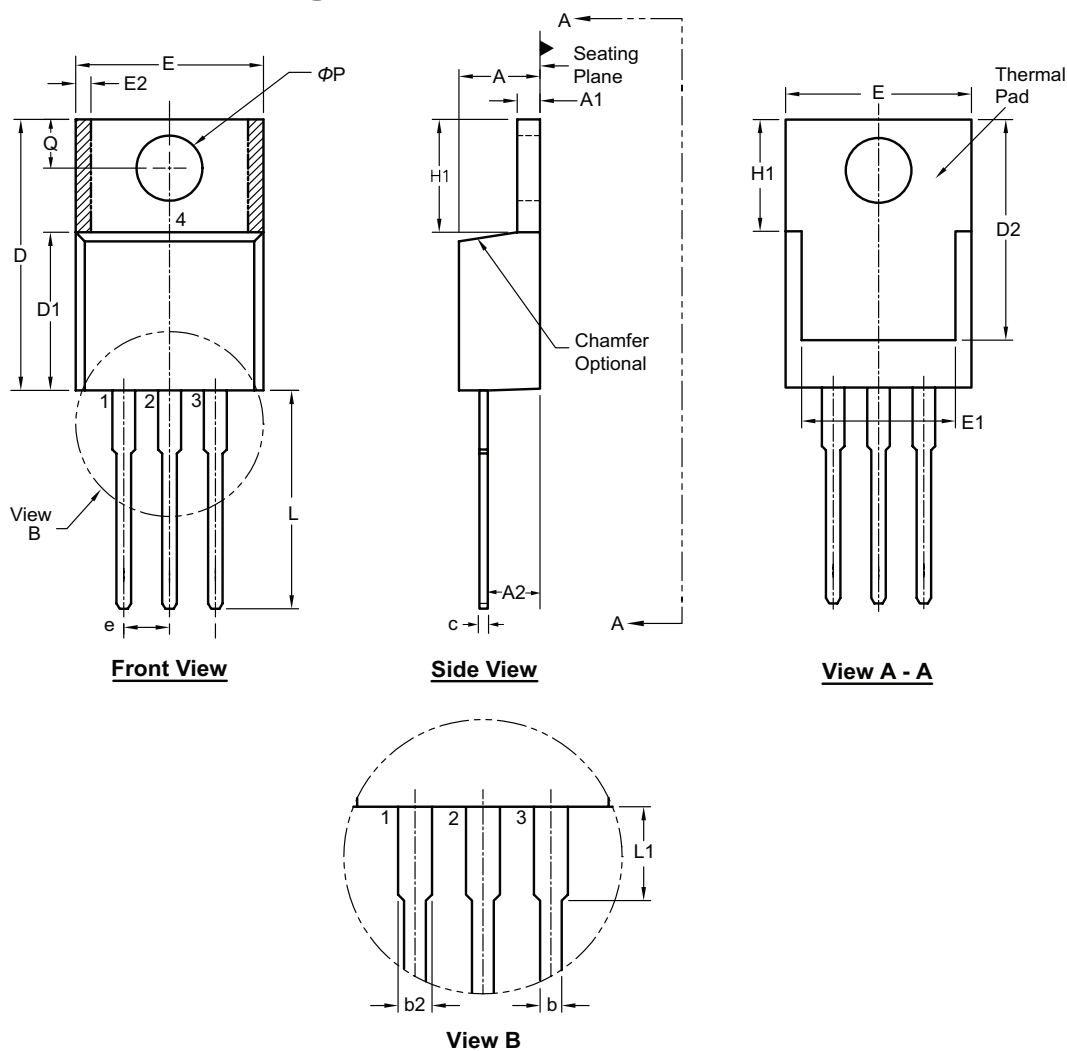

Symbol		A	A1	A2	b	b2	c	D	D1	D2	E	E1	E2	e	H1	L	L1	Q	ΦP	
Dimension (inches)	MIN	.140	.020	.080	.015	.045	.012 [†]	.560	.326 [†]	.474 [†]	.380	.270	0.20*	.100 BSC	.230	.500	.200*	.100	.139	
	NOM	-	-	-	.027	.057	-	-	-	-	-	-	-		-	-	-	-	-	-
	MAX	.190	.055	.120 [†]	.040	.070	.024	.650	.361 [†]	.507	.420	.350	.030		.270	.580	.250	.135	.161	

JEDEC Registration TO-220, Variation AB, Issue K, April 2002.

* This dimension is not specified in the JEDEC drawing.

† This dimension differs from the JEDEC drawing.

Drawings not to scale.

Supertex Doc. #: DSPD-3TO220N5, Version C041009.

(The package drawings in this data sheet may not reflect the most current specifications. For the latest package outline information go to <http://www.supertex.com/packaging.html>.)

Supertex inc. does not recommend the use of its products in life support applications, and will not knowingly sell them for use in such applications unless it receives an adequate "product liability indemnification insurance agreement." **Supertex inc.** does not assume responsibility for use of devices described, and limits its liability to the replacement of the devices determined defective due to workmanship. No responsibility is assumed for possible omissions and inaccuracies. Circuitry and specifications are subject to change without notice. For the latest product specifications refer to the **Supertex inc.** (website: <http://www.supertex.com>)