

AnadigmFilter1™ Universal Programmable Filter 6th Order, DC up to 600kHz with Gain

Anadigm's AnadigmFilter™ is the first of a family of chipsets from Anadigm using its dynamically programmable Analog Signal Processor (dpASP) plus State Machine to realize a dynamically programmable universal analog filter. This first application solution realizes 6th order filters, Low pass, band pass, high pass or band stop circuits can be configured with filters approximating to Butterworth, Bessel, chebyshev or inverse chebyshev. Further there are two pass/stop band widths for the band pass and band stop filters and the ability to configure the circuit to bypass mode which provides a flat unfiltered response.

It consists of a choice of 2 fixed input stages which can be configured using external resistors and capacitors to provide any or all of the following: gain or attenuation, level shifting, single-ended to differential conversion, 1st order lowpass or highpass filtering. In addition within the core of the dpASP device there is 6th order filter which can be programmed via a simple 16 bit control word, either statically by hardwiring or setting DIP switches on 16 inputs, or dynamically from a controller using a 16 bit data bus.

Both gain and stop band frequency can be dynamically programmed on the fly WITHOUT interruption to the signal. In addition, the user can select between one of two inputs, or both inputs summed, or both inputs disconnected. The outputs are fully differential for greater immunity to noise and supply ripple.

Power in operation is typically 200mW and there is a low current standby mode.

AnadigmFilter1™ Features

- 128 Programmable stop band frequency for each input clock frequency (input clock is user defined). These frequencies settings are arranged in octaves with 8 settings/octave or 9% spacing or step size.
- Programmable stop band frequency from DC upto 500kHz low pass, 100kHz high pass, 600kHz band pass, 120kHz band stop
- Programmable gain – 8 settings in 3dB steps
- Frequency and gain programmable without signal interruption.
- 4 Filter types – Butterworth, Chebyshev, Inverse Chebyshev (0.5dB passband ripple) and Bessel.
- Extremely simple to use 16 pin programming interface for static or dynamic programming.
- 2 input stages configurable using external resistors and capacitors for optimum signal interfacing and additional filter.
- Differential or single-ended signal input
- Fully differential analog signal outputs for better immunity to noise and supply ripple

Filter Topology and approximation Availability chart	Lowpass	Highpass	Bandpass	Bandstop
Butterworth	✓	✓	x	x
Bessel	✓	✓	✓	✓
Chebyshev	✓	✓	x	x
Inverse Chebyshev	x	x	✓	✓

Filter variables Availability chart	Lowpass	Highpass	Bandpass	Bandstop
8 values of Fc/octave	✓	✓	✓	✓
Selectable 1 or 2 inputs with summing stage	✓	✓	✓	✓
Gain selection Mute to 18db in 3dB steps	✓	✓	✓	✓
Maximum Fc (kHz)	500	100	600	120
Wide and narrow filter	-	-	✓	✓

AnadigmFilter™ Benefits

Gain and Frequency dynamically programmable without signal interruption	Low operational power 190mW, low standby current 20mW
Extremely simple to use programming interface	Easy interfacing to analog signals
Choice of filter topology and approximations	Reduced number of system components

dpASP Sub Module - Analog signal path
(Functionally equivalent drawing)

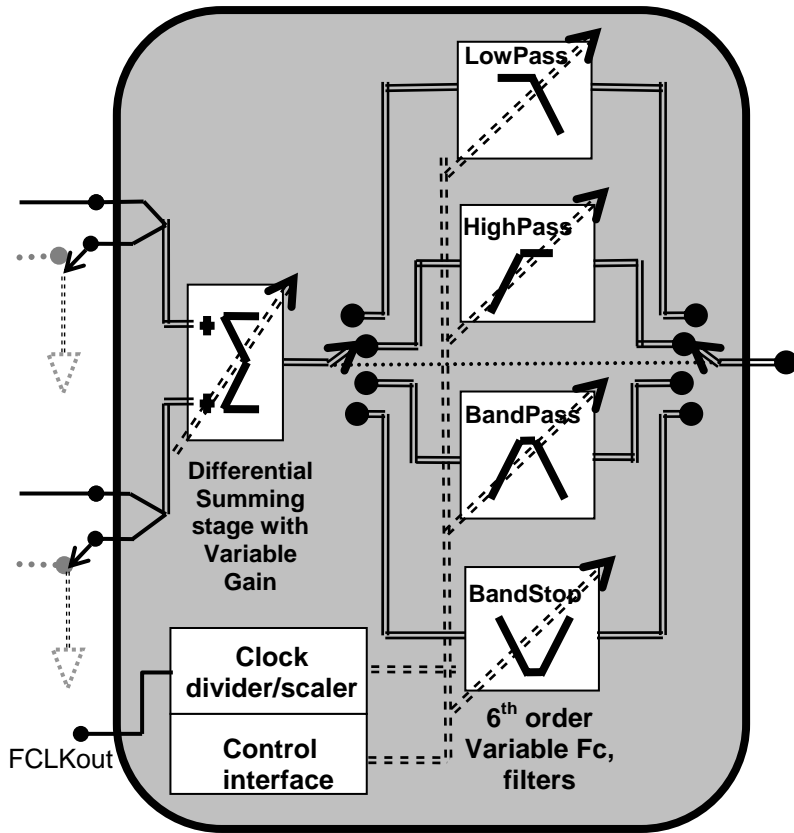

AnadigmFilter1 Solution uses 2 ICs

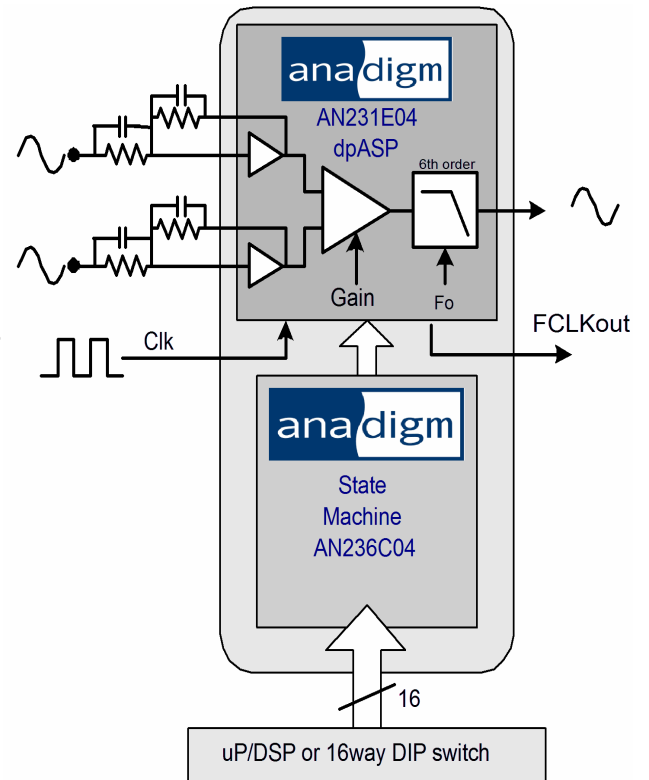

To calculate the corner or center frequency of any filter use the following equation

$$\text{CORNER FREQUENCY} = (F(\text{ack}) / \text{“Divisor_B”}) * \text{“Divisor_A”} * \text{“Divisor_C”}$$

F(ack) is the external clock frequency applied to the AN231E04 device ACLK pin, pin number 34.

Divisor A, B and C, see table below.

AnadigmFilter1 (lower 8 bits of the 16 Bit Configuration Word)

Divisor_B <i>Internal Clock divider settings, (divider to scale Fc in octave steps)</i>				Divisor_A <i>Filter Fc settings (9% steps across octave)</i>			Divisor_C <i>Filter topology max Fc factor</i>	
B4	B3	B2	B1	A3	A2	A1		
C6	C5	C4	C3	C2	C1	C0		
Pin 13	Pin 14	Pin 15	Pin 16	Pin 17	Pin 18	Pin 19		
B4,B3,B2,B1				A3,A2,A1				
DivisorB				DivisorA				
0000				000			low pass	0.05
0001				001			High Pass	0.01
0010				010			Bandpass	0.05
0011				011			Bandstop	0.03
0100				100				
0101				101				
0110				110				
0111				111				
1000								
1001								
1010								
1011								
1100								
1101								
1110								
1111								

ANADIGM AnadigmFilter1 Control Interface (16 Bit Configuration Word)

Gain Settings			Analog Input Pin settings		Filter Topology		Filter approximation		DivisorB <i>Internal Clock divider settings, (divider to scale Fc in octave steps)</i>				DivisorA <i>Filter Fc settings (9% steps across octave)</i>		
MSB															LSB
G3	G2	G1	I2	I1	T4	T3	T2	T1	B4	B3	B2	B1	A3	A2	A1
C15	C14	C13	C12	C11	C10	C9	C8	C7	C6	C5	C4	C3	C2	C1	C0
Pin 2	Pin 3	Pin 4	Pin 5	Pin 6	Pin 7	Pin 10	Pin 11	Pin 12	Pin 13	Pin 14	Pin 15	Pin 16	Pin 17	Pin 18	Pin 19
G3,G2,G1	Gain (dBs)	I2,I1	Active input(s)	T4,T3	Filter topology	The Filter Approximation applied depends upon the Filter topology selected. See Table insert to the lower left			B4,B3,B2,B1	DivisorB	A3,A2,A1	DivisorA			
000	-infinity (Mute)	00	None	00	Lowpass				0000	1	000	1.0			
001	0.0	01	Input A	01	Highpass				0001	2	001	0.917			
010	3.0	10	Input B	10	Bandpass				0010	4	010	0.841			
011	6.0	11	A & B <i>Note1</i>	11	Bandstop				0011	8	011	0.771			
100	9.0								0100	16	100	0.707			
101	12.0	0101	32	101	0.648										
110	15.0	0110	64	110	0.595										
111	18.0	0111	128	111	0.545										

Filter Approximation Applied	T4,T3	T2,T1	Comme	Width	Limits (FCLK = ACLK / DivisorB)
Lowpass Butterworth	00	00		n/a	Max Fc = 400kHz @ FCLK(max) = 8MHz
Lowpass Chebyshev	00	01		n/a	Max Fc = 500kHz @ FCLK(max) = 10MHz
Lowpass Bessel	00	10		n/a	Max Fc = 250kHz @ FCLK(max) = 5MHz
Lowpass Bypass	00	11		n/a	Max Fc = 1000kHz @ FCLK(max) = 10MHz
Highpass Butterworth	10	00		n/a	Max Fc = 60kHz @ FCLK(max) = 6MHz
Highpass Chebyshev	10	01		n/a	Max Fc = 100kHz @ FCLK(max) = 10MHz
Highpass Bessel	10	10		n/a	Max Fc = 50kHz @ FCLK(max) = 5MHz
Highpass Bypass	10	11		n/a	Max Fc = 1000kHz @ FCLK(max) = 10MHz
Bandpass Inverse Chebyshev	01	01	narrow	10%	Max Fc = 500kHz @ FCLK(max) = 10MHz
Bandpass Bessel	01	01	narrow	10%	Max Fc = 600kHz @ FCLK(max) = 12MHz
Bandpass Inverse Chebyshev	01	10	wider	40%	Max Fc = 500kHz @ FCLK(max) = 10MHz
Bandpass Bessel	01	11	wider	40%	Max Fc = 600kHz @ FCLK(max) = 12MHz
Bandstop Inverse Chebyshev	11	00	narrow	20%	Max Fc = 120kHz @ FCLK(max) = 4MHz
Bandstop Bessel	11	01	narrow	20%	Max Fc = 120kHz @ FCLK(max) = 4MHz
Bandstop Inverse Chebyshev	11	10	wider	80%	Max Fc = 120kHz @ FCLK(max) = 4MHz
Bandstop Bessel	11	11	wider	80%	Max Fc = 120kHz @ FCLK(max) = 4MHz

1000	256
1001	512
1010	1024
1011	2048
1100	4096
1101	8192
1110	16384
1111	32768

Notes

- 1) If inputs A and B are selected then the two active input signals will be summed.
- 2) Setting of five 0's for the control bits C[15:11] (zero gain and no inputs selected) causes the FPAA to be reset and AnadigmFilter to go into standby (approx 6mA from 3.3volts)
- 3) Max Fc, or maximum Filter Corner or Center Frequency limits have been determined for better than 1% accurate filter parameters, exceeding these limits will result in loss of filter accuracy.
- 4) Bypass filter approximation provides a flat response from d.c. to FCLK * 0.1. (FCLK = ACLK / Divisor_B). Divisor_A inputs have no effect in this mode, gain and input select still apply.
- 5) Divisor_A step size is mathematically equal to $(8\sqrt[3]{2})$ or $(2)^{1/8}$.
- 6) FCLK (= ACLK / DivisorB) is provided on an output pin from the AN231E04, the primary purpose of this signal is to enable synchronization of any subsequent ADC,

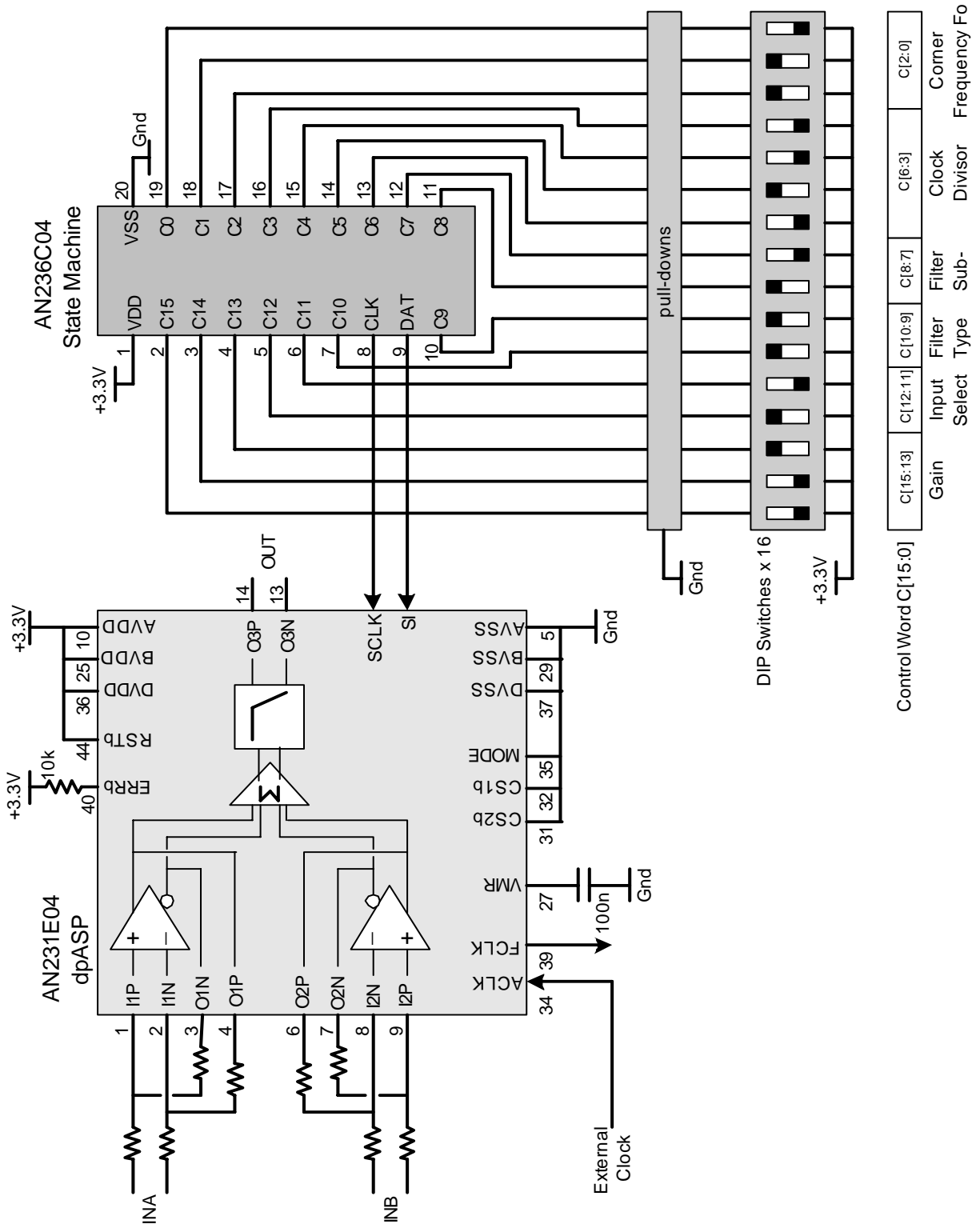

Product codes

- Evaluation Kit AN236K04-EVAL2
- Sample Chipset AN236K04-SETSP (contains 1 x AN231E04-QFNSP and 1 x AN236C04-SSOSP)
- Volume Chipset AN236K04-SETTY (contains 1 x AN231E04-QFNTY and 1 x AN236C04-SSOTU)

For more information:
 Telephone: +1 480 422 0191
 Email: support@anadigm.com
 web: www.anadigm.com