

# 500 MSPS CAMERA LINK DATA ACQUISITION BOARD



## Product Features & Benefits

- 1 channel 500MS/s
- 12-bit Resolution
- Supports a wide range of laser sweep rates
- 200MHz Bandwidth (configurable)
- Number of points per A Scan configurable
- Configurable with external k-clock or internal 500MSPS clock
- A-line trigger output via SMA connector
- Base Camera Link® interface configuration
- 85MHz, 24 bit Pixel Data
- USB interface

## Applications

- Optical Coherence Tomography for
  - Ophthalmology
  - Gastrointestinal
  - Cancer Diagnosis
  - Pulmonary
  - Industrial Imaging
  - Research & Development

## Introducing the AXSUN 500MSPS DAQ Board

To meet the performance needs of next-generation Optical Coherence Tomography (OCT) systems, Axsun Technologies introduces a high speed 12-bit Data Acquisition board compatible with Axsun's high performance swept laser OCT Engine products.

## Product Description

The AXSUN DAQ board has a 12-bit 500 MSPs front end, configurable with either an external k-trigger, or an internal trigger, and a base Camera Link® (CL) interface to transmit OCT spectral data to your image processing electronics. The Axsun CL-DAQ card is designed to interface seamlessly with commercial CL Frame Grabbers and provide a straightforward Swept Source upgrade path to Camera based OCT systems.

## Convenience and Small Form Factor

The Axsun high speed DAQ board resides in a compact (~114 x 177 x 13 mm) package and is straightforward to integrate with the Axsun Swept Source Engine. The single DC supply, and USB interface allow the user to begin collecting data in a matter of minutes.

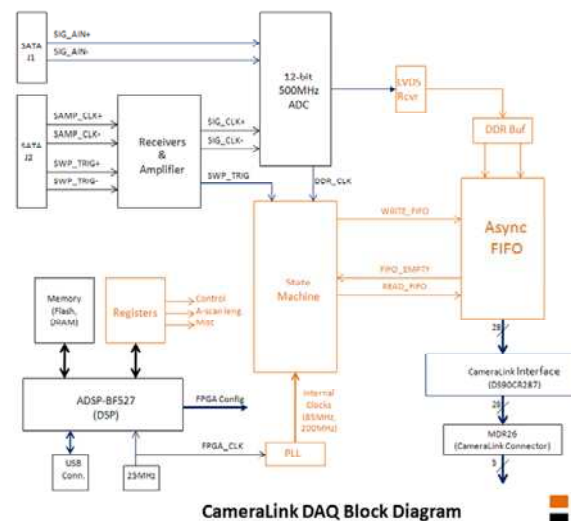

CameraLink DAQ Board Simplified Block Diagram

## PERFORMANCE SPECIFICATIONS FOR CL DAQ BOARD

Parameter	CLDAQ 12500			
	Min	Typ	Max	Units
A/D Resolution		12		Bits
ENOB		10.7		Bits
Sampling Rate	40		500	MSPs
Sweep Rep Rate <sup>1</sup>	20		150	kHz
Input Connectors		SATA		
Trigger/Clock/Detector input level		LVDS		
Output Connector		Camera Link		
Camera Link® Configuration		Base		85MHz 24-bit
Video Throughput Rate			255	MB/s
Bandwidth (-3dB)		200		MHz
Input Voltage Range (differential)		± 1.1		V
Power Supply		12		VDC
Mechanical Dimensions	~114 X 177 X 13 mm ~ 4.5 X 7 x 0.51 inches			
Interfaces				
USB (optional)	USB-B			

1. Dependent on Swept laser linearization and maximum K clock frequency.

Axsun SSOCT Engine with DAQ Board



For more information

Contact AXSUN at:

AXSUN Technologies

1 Fortune Drive

Billerica, MA 01821

USA

+1 978.262.0049

info@axsun.com

Copyright © 2010  
AXSUN Technologies Inc.