

DESCRIPTION

QBAR® ICs provide a 3-terminal semiconductor switch that functions as:

- a solid-state normally-closed switch
- a non-inverting digital transistor
- a solid-state replacement for a normally-closed, non-isolating relay.

QBAR® ICs do not require a separate power supply lead. This makes possible:

- simplified control wiring
- replacement of normally-closed D.C. relays with highly reliable solid-state devices
- improved fail-safe performance in the event of lost control power, severed or shorted control wires.

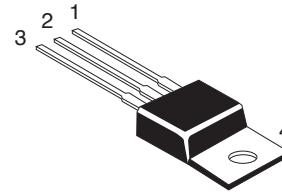

3 AMPERES
20 VOLTS
TO-220 package

PIN
1 INPUT
2 GND
3 OUTPUT
4 GND

QBAR SWITCH SYMBOL

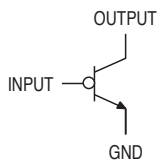

FUNCTIONAL SCHEMATIC

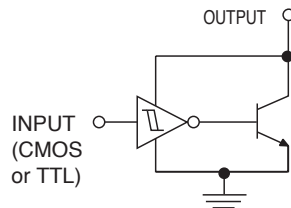

FUNCTION TABLE

INPUT	SWITCH STATE (OUTPUT-TO-GND)
HI	OFF
LO	ON
OPEN	ON

TYPICAL APPLICATIONS

ALARM SWITCH

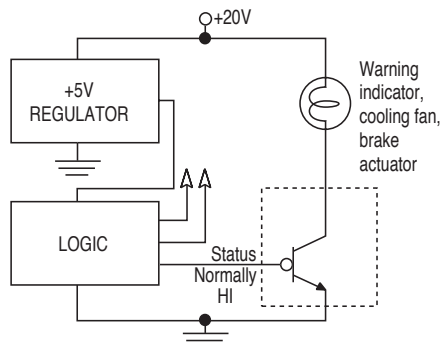

A QBAR switch activates an alarm over a large range of system failure conditions:

- system failure indicated by a LO on the status output
- status conductor cut
- status conductor shorted to ground
- loss of +5V supply

Any of these conditions will cause the QBAR switch to turn ON and power the alarm.

PROTECTION OF FRAGILE OR TRIGGER DEVICES

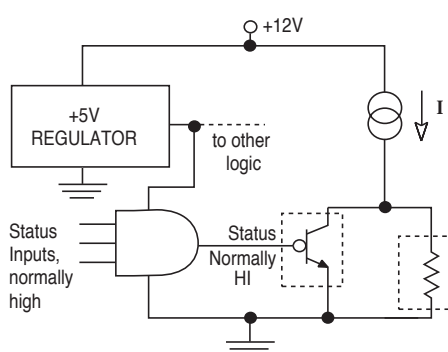

A QBAR switch protects the load from being driven by false signals when all status indicators are *not* OK. Damage to fragile loads such as laser diodes, or erroneous firing of detonators can be avoided with a QBAR switch. It shunts drive current I around the load when any Status Gate input goes LO, when +5V power is lost, or when the conductor from the Status Gate output to the QBAR switch input is cut or shorted to ground.

POWER SUPPLY EFFICIENCY BOOST

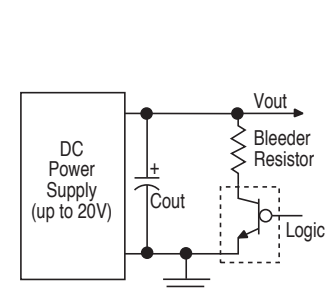

Increase your power supply efficiency by using a QBAR switch to lower the parasitic current drain through the bleeder resistor during normal supply operation.

QB210T

ABSOLUTE MAXIMUM RATINGS

Voltage, output to ground	24 V	
Voltage, input to ground	±6 V	(OK to exceed +6V if Input Current is limited to 2mA)
Operating Temperature Range, T case	0°C to 70°C	
Storage Temperature Range	-55°C to 150°C	
Output current, continuous	3A	

ELECTRICAL SPECIFICATIONS (Over full operating temperature range, unless noted)

PARAMETER	CONDITIONS	MIN	TYP	MAX	UNITS
<u>OFF Characteristics</u>					
Output Breakdown Voltage	V input ≥ 2.4 V I output ≤ 750 μA	20			V
Output OFF Current	V input ≥ 2.4 V V output = 20 V		+300	+750	μA
Input HIGH Logic Threshold			1.7	2.4	V
Input HIGH Input Current	V input = 2.4 V	0		+60	μA
<u>ON Characteristics</u>					
Output ON Voltage	V input ≤ 0.8 V I output = 1.80 A		1.3	1.8	V
Input LOW Logic Threshold		0.8	1.4		V
Input LOW Input Current	-6 V ≤ V input ≤ 0.8 V	-20		+20	μA
Input Logic Threshold Hysteresis		0.1			V
<u>SWITCHING Characteristics</u>					
Turn-on Time, Turn-off Time	V in0 = 0.8 V V in1 = 2.4 V Vcc = 12 V I out = 50 mA		2	5	μs

Notes:

- When not connected, the Input Terminal floats LOW, putting the QBAR® switch in the ON state. Nevertheless, for minimum noise susceptibility, inputs should be connected to valid logic levels.
- QBAR switches are protected by U.S. Patent # 5,134,323 and foreign patents.

Available Options:

Package	Max Current	Suffix	Order No.
SOT-23	175mA	M3	QB104M3
TO-92	175mA	Z	QB104Z
TO-220	3A	T	QB210T

Contact BitParts, Inc. for other package options.



BitParts, Inc.
505 East Travis Street, #205 Marshall TX 75670
bitparts@bitpartsinc.com
www.bitpartsinc.com

BITPARTS, INC. reserves the right to make changes without further notice to these components to improve reliability, function or design. BITPARTS, INC. assumes no liability arising from the use of these components. The products of BITPARTS, INC. are not intended for use in life support appliances, devices, or systems. Use of a BITPARTS, INC. product in such applications without the written consent of the President of BITPARTS, INC. is prohibited.

QBAR is a registered trademark of BitParts, Inc.

© Copyright 2012 BitParts, Inc. All rights reserved.

Ref: QB210T—2/99