

THC63LVD104C

112MHz 30Bits COLOR LVDS Receiver

General Description

The THC63LVD104C receiver is designed to support pixel data transmission between Host and Flat Panel Display from NTSC up to SXGA resolutions. The THC63LVD104C converts the LVDS data streams back into 35bits of CMOS/TTL data with the choice of the rising edge or falling edge clock for the convenience with a variety of LCD panel controllers. At a transmit clock frequency of 112MHz, 30bits of RGB data and 5bits of timing and control data (HSYNC, VSYNC, DE, CNTL1, CNTL2) are transmitted at an effective rate of 784Mbps per LVDS channel. Using a 112MHz clock, the data throughput is 490Mbytes per second.

Features

- Wide dot clock range: 8-112MHz suited for NTSC, VGA, SVGA, XGA, and SXGA
- PLL requires no external components
- 50% output clock duty cycle
- TTL clock edge programmable
- Power down mode
- Low power single 3.3V CMOS design
- 64pin TQFP
- Backward compatible with THC63LVDF64x (18bits) / F84x(24bits)
- Pin compatible with THC63LVD104A
- Fail-safe for Open LVDS Input

Block Diagram

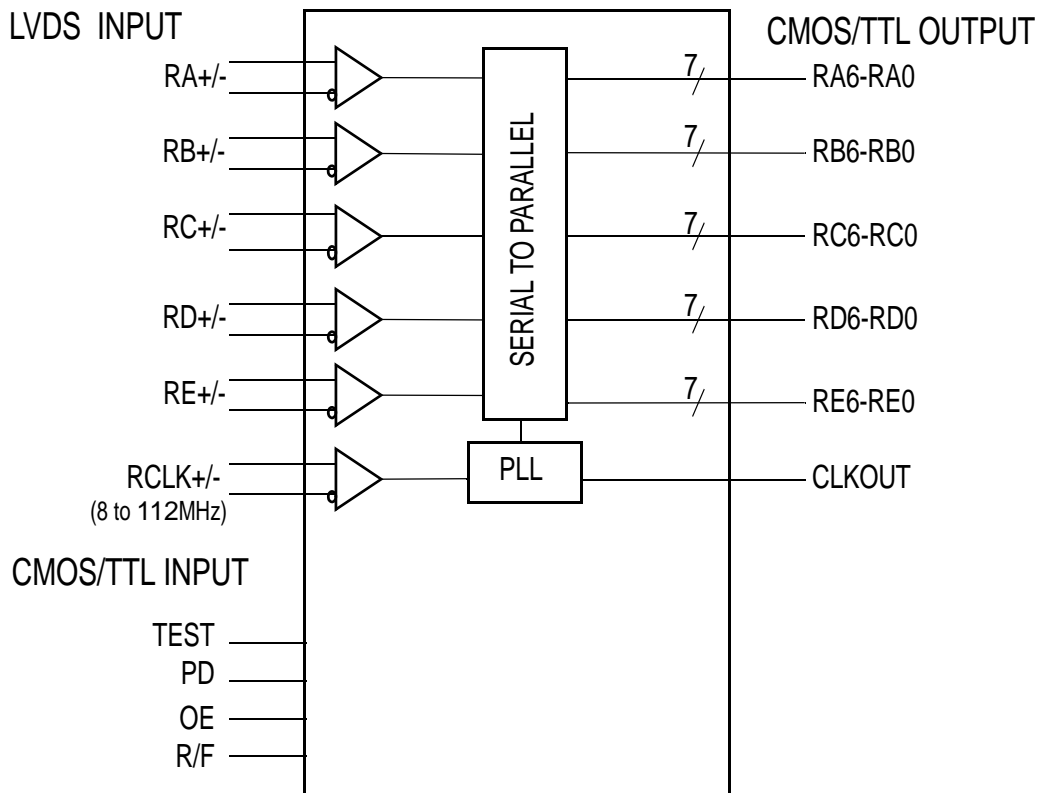

Pin Out

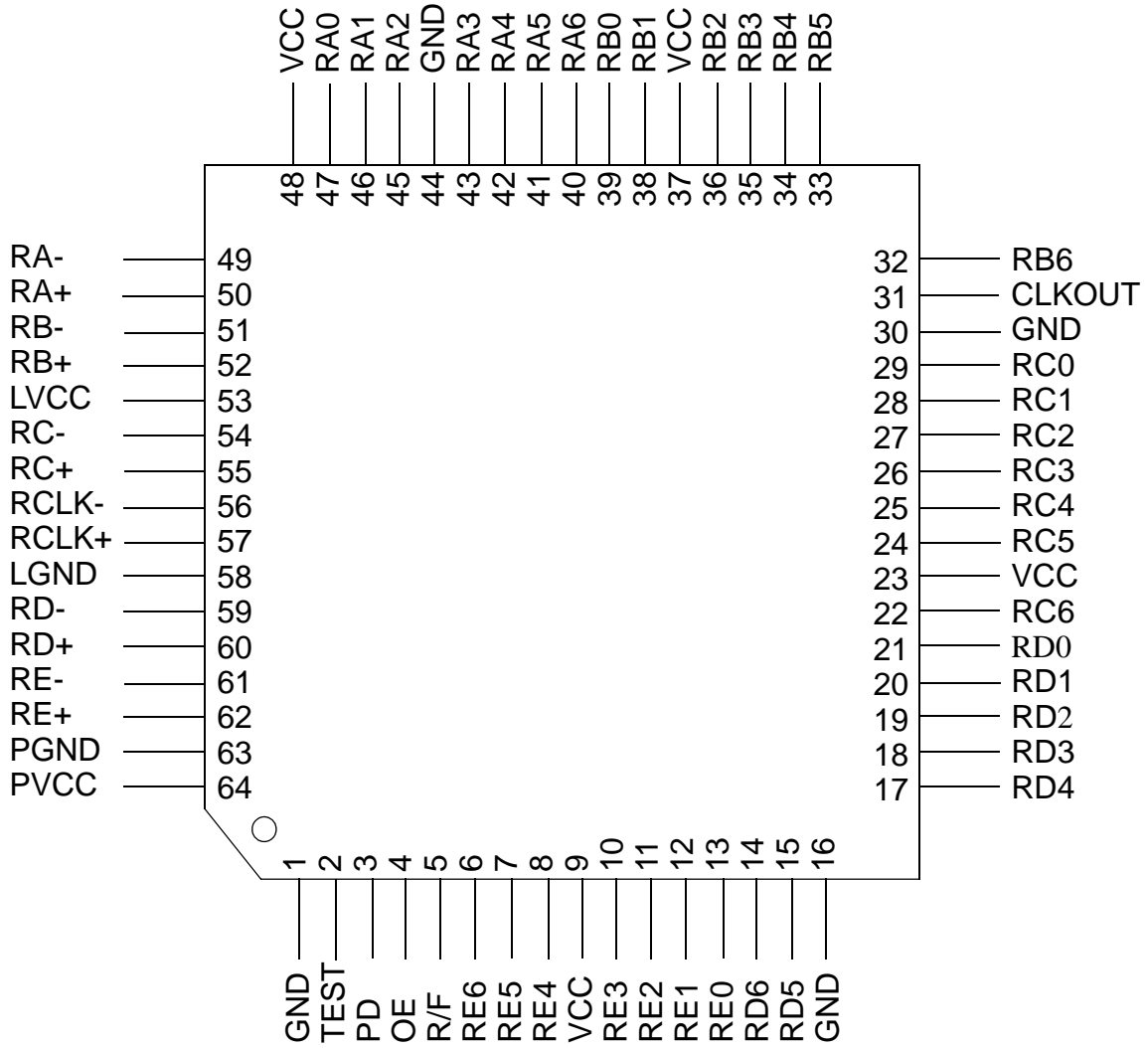

Pin Description

Pin Name	Pin #	Type	Description
RA+, RA-	50, 49	LVDS IN	LVDS Data In.
RB+, RB-	52, 51	LVDS IN	
RC+, RC-	55, 54	LVDS IN	
RD+, RD-	60, 59	LVDS IN	
RE+, RE-	62, 61	LVDS IN	
RCLK+, RCLK-	57, 56	LVDS IN	LVDS Clock In.
RA6 ~ RA0	40,41,42,43,45,46,47	OUT	CMOS/TTL Data Outputs.
RB6 ~ RB0	32,33,34,35,36,38,39	OUT	
RC6 ~ RC0	22,24,25,26,27,28,29	OUT	
RD6 ~ RD0	14,15,17,18,19,20,21	OUT	
RE6 ~ RE0	6,7,8,10,11,12,13	OUT	
TEST	2	IN	Test pin, must be "L" for normal operation.
PD	3	IN	H: Normal operation, L: Power down (all outputs are "L")
OE	4	IN	H: Output enable (Normal operation). L: Output disable(all outputs are Hi-Z)
R/F	5	IN	Output Clock Triggering Edge Select. H: Rising edge, L: Falling edge
VCC	9,23,37,48	Power	Power Supply Pins for TTL outputs and digital circuitry.
CLKOUT	31	OUT	Clock out.
GND	1,16,30,44	Ground	Ground Pins for TTL outputs and digital circuitry.
LVCC	53	Power	Power Supply Pin for LVDS inputs.
LGND	58	Ground	Ground Pin for LVDS inputs.
PVCC	64	Power	Power Supply Pin for PLL circuitry.
PGND	63	Ground	Ground Pin for PLL circuitry.

PD	R/F	OE	Data Outputs (Rxn)	CLKOUT
0	0	0	Hi-Z	Hi-Z
0	0	1	All 0	Fixed Low
0	1	0	Hi-Z	Hi-Z
0	1	1	All 0	Fixed Low
1	0	0	Hi-Z	Hi-Z
1	0	1	Data Out	The falling edge closer to the center of the data eye.
1	1	0	Hi-Z	Hi-Z
1	1	1	Data Out	The rising edge closer to the center of the data eye.

** Rxn

x = A,B,C,D,E

n = 0,1,2,3,4,5,6

Absolute Maximum Ratings¹

Supply Voltage ($V_{CC}=V_{CC}=LV_{CC}=PV_{CC}$)	-0.3V ~ +4.0V
CMOS/TTL Input Voltage	-0.3V ~ ($V_{CC} + 0.3V$)
CMOS/TTL Output Voltage	-0.3V ~ ($V_{CC} + 0.3V$)
LVDS Receiver Input Voltage	-0.3V ~ ($V_{CC} + 0.3V$)
Output Current	-30mA ~ 30mA
Junction Temperature	+125°C
Storage Temperature Range	-55°C ~ +150°C
Reflow Peak Temperature / Time	+260°C / 10sec.
Maximum Power Dissipation @+25°C	2.1W

Electrical Characteristics

CMOS/TTL DC Specifications

$V_{CC} = LV_{CC} = PV_{CC} = 3.0V \sim 3.6V$, $T_a = -20^\circ C \sim +85^\circ C$

Symbol	Parameter	Conditions	Min.	Typ.	Max.	Units
V_{IH}	High Level Input Voltage		2.0		V_{CC}	V
V_{IL}	Low Level Input Voltage		GND		0.8	V
V_{OH}	High Level Output Voltage	$I_{OH} = -4mA$ (data) $I_{OH} = -8mA$ (clock)	2.4			V
V_{OL}	Low Level Output Voltage	$I_{OL} = 4mA$ (data) $I_{OL} = 8mA$ (clock)			0.4	V
I_{INC}	Input Current	$0V \leq V_{IN} \leq V_{CC}$			± 10	μA

LVDS Receiver DC Specifications

$V_{CC} = LV_{CC} = PV_{CC} = 3.0V \sim 3.6V$, $T_a = -20^\circ C \sim +85^\circ C$

Symbol	Parameter	Conditions	Min.	Typ.	Max.	Units
V_{TH}	Differential Input High Threshold	$V_{IC} = 1.2V$			100	mV
V_{TL}	Differential Input Low Threshold	$V_{IC} = 1.2V$	-100			mV
I_{INL}	Input Current	$V_{IN} = 2.4V / 0V$ $V_{CC} = 3.6V$			30	μA

1. "Absolute Maximum Ratings" are those values beyond which the safety of the device can not be guaranteed. They are not meant to imply that the device should be operated at these limits. The tables of "Electrical Characteristics" specify conditions for device operation.

Supply Current

VCC =LVCC=PVCC= 3.0V ~ 3.6V, Ta = -20°C ~ +85°C

Symbol	Parameter	Conditions		Typ.	Max.	Units
I _{RCCW}	Receiver Supply Current (LVDS Full Toggle)	f _{CLKOUT} = 75MHz	CL=8pF, V _{CC} =3.6V, Ta= -20°C ~ 85°C		205	mA
		f _{CLKOUT} = 90MHz			236	mA
		f _{CLKOUT} = 112MHz	CL=8pF, V _{CC} =3.6V, Ta= -20°C ~70°C *		280	mA
I _{RCCS}	Receiver Power Down Supply Current	PD = L			25	μA

*The trade-off between the output load and the ambient temperature exists so that the junction temperature does not exceed 125°C.

LVDS Full Toggle Pattern

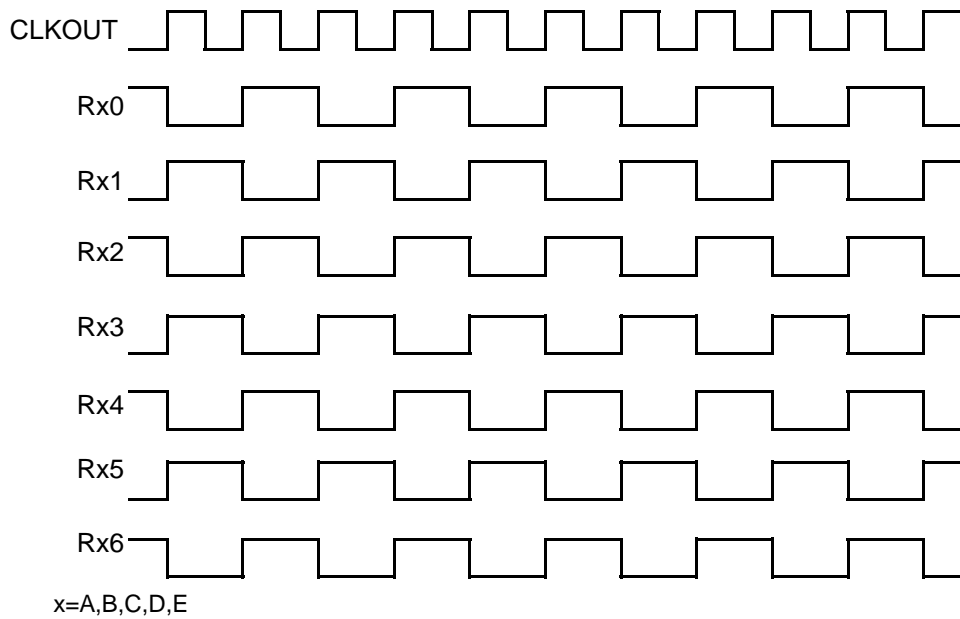

Output load limitation

The output load is limited so that the junction temperature does not exceed 125°C .

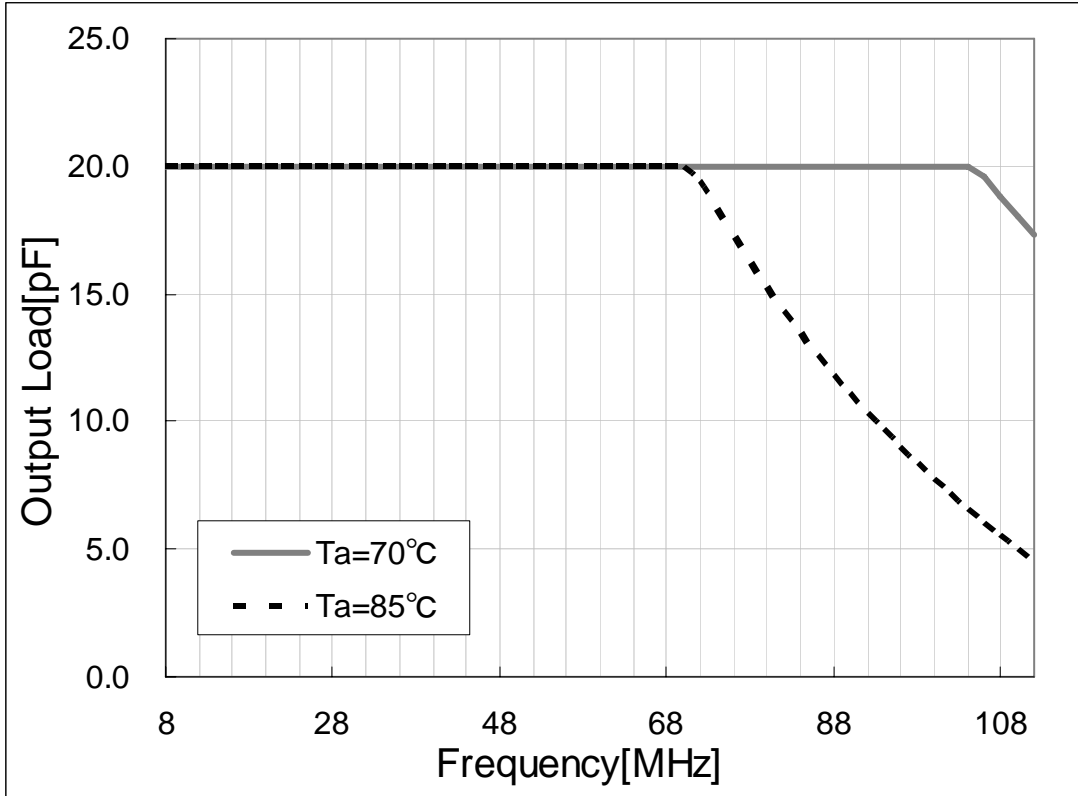

Switching Characteristics

VCC = LVCC = PVCC = 3.0V ~ 3.6V, Ta = -20°C ~ +85°C

Symbol	Parameter		Min.	Typ.	Max.	Units
t _{RCP}	CLKOUT Period		8.92	T	125.0	ns
t _{RCH}	CLKOUT High Time			$\frac{T}{2}$		ns
t _{RCL}	CLKOUT Low Time			$\frac{T}{2}$		ns
t _{RS}	TTL Data Setup to CLKOUT		$\frac{4}{7}t_{RCP} - 1$			ns
t _{RH}	TTL Data Hold from CLKOUT		$\frac{3}{7}t_{RCP} - 1$			ns
t _{TLH}	TTL Low to High Transition Time			1.0	3.0	ns
t _{THL}	TTL High to Low Transition Time			1.0	3.0	ns
t _{SK}	Receiver Skew Margin	CLKOUT=50MHz	-1000	0	1000	ps
		CLKOUT=75MHz	-550	0	550	ps
		CLKOUT=90MHz	-400	0	400	ps
		CLKOUT=112MHz	-250	0	250	ps
t _{RIP1}	Input Data Position0		- t _{SK}	0	+ t _{SK}	ns
t _{RIP0}	Input Data Position1		$\frac{t_{RCIP}}{7} - t_{SK}$	$\frac{t_{RCIP}}{7}$	$\frac{t_{RCIP}}{7} + t_{SK}$	ns
t _{RIP6}	Input Data Position2		$2\frac{t_{RCIP}}{7} - t_{SK}$	$2\frac{t_{RCIP}}{7}$	$2\frac{t_{RCIP}}{7} + t_{SK}$	ns
t _{RIP5}	Input Data Position3		$3\frac{t_{RCIP}}{7} - t_{SK}$	$3\frac{t_{RCIP}}{7}$	$3\frac{t_{RCIP}}{7} + t_{SK}$	ns
t _{RIP4}	Input Data Position4		$4\frac{t_{RCIP}}{7} - t_{SK}$	$4\frac{t_{RCIP}}{7}$	$4\frac{t_{RCIP}}{7} + t_{SK}$	ns
t _{RIP3}	Input Data Position5		$5\frac{t_{RCIP}}{7} - t_{SK}$	$5\frac{t_{RCIP}}{7}$	$5\frac{t_{RCIP}}{7} + t_{SK}$	ns
t _{RIP2}	Input Data Position6		$6\frac{t_{RCIP}}{7} - t_{SK}$	$6\frac{t_{RCIP}}{7}$	$6\frac{t_{RCIP}}{7} + t_{SK}$	ns
t _{RPLL}	Phase Lock Loop Set				10.0	ms
t _{RCD}	RCLK +/- to CLKOUT Delay	CLKOUT=75MHz	46.5		52.5	ns
t _{RCIP}	CLKIN Period		8.92		125.0	ns

AC Timing Diagrams

TTL Outputs

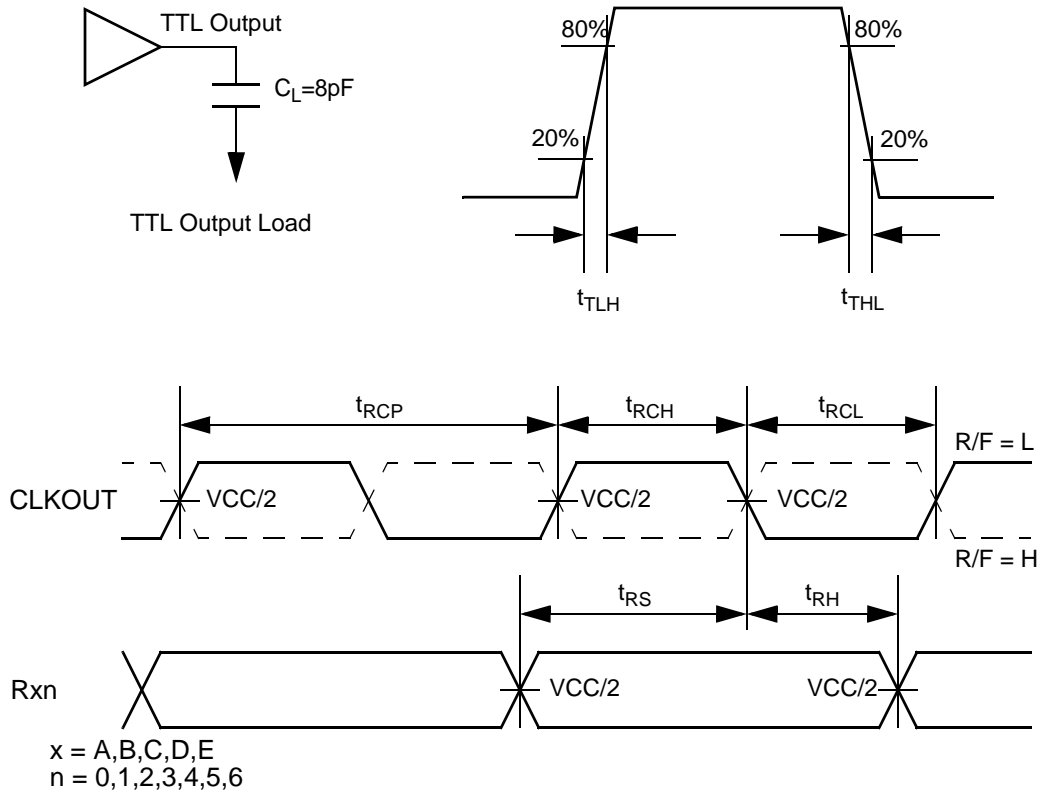

AC Timing Diagrams

Phase Lock Loop Set Time

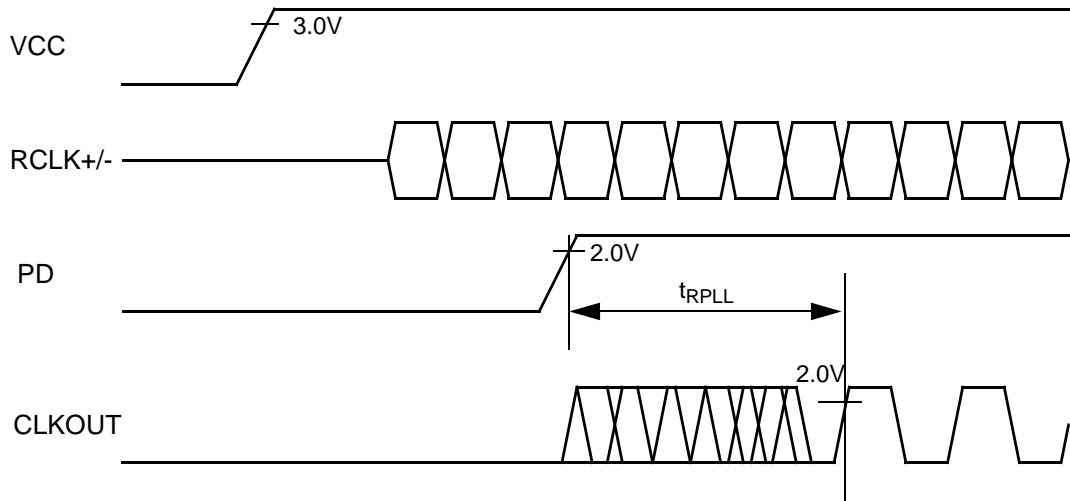

RCLK +/- to CLKOUT Delay

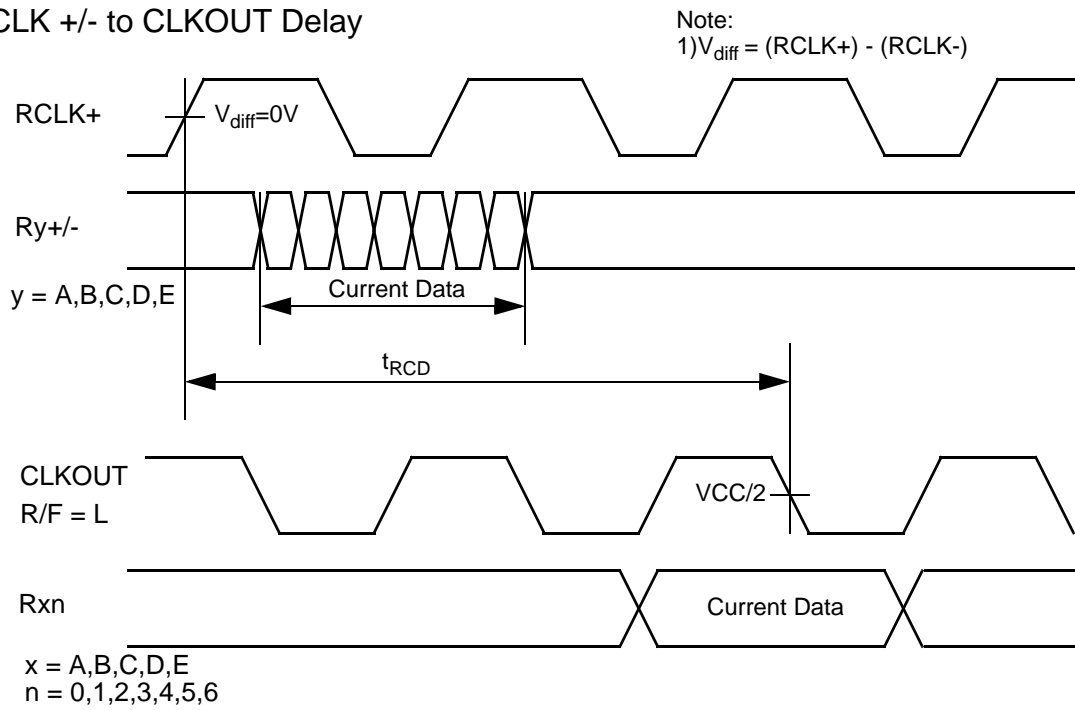

AC Timing Diagrams

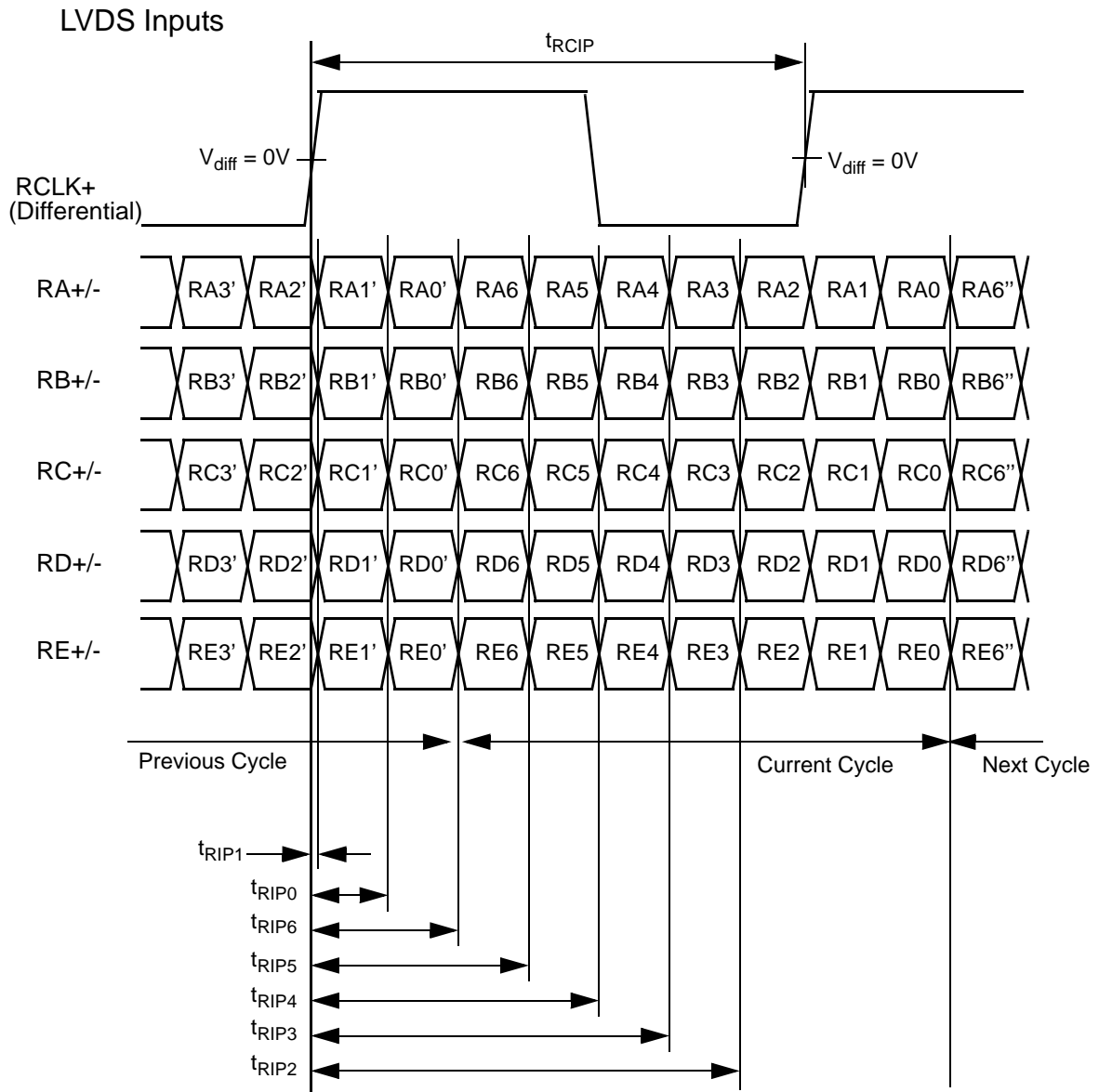

Note

1)Power On Sequence

Power on LVDS-Tx after THC63LVD104C.

2)Cable Connection and Disconnection

Don't connect and disconnect the LVDS cable, when the power is supplied to the system.

3)GND Connection

Connect the each GND of the PCB which LVDS-Tx and THC63LVD104C on it. It is better for EMI reduction to place GND cable as close to LVDS cable as possible.

4)Multi Drop Connection

Multi drop connection is not recommended.

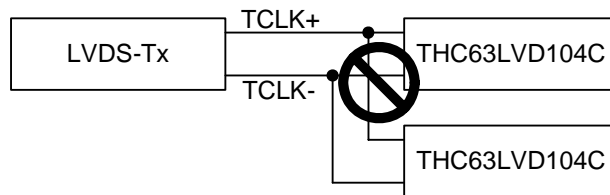

5)Asynchronous use

Asynchronous use such as following systems are not recommended.

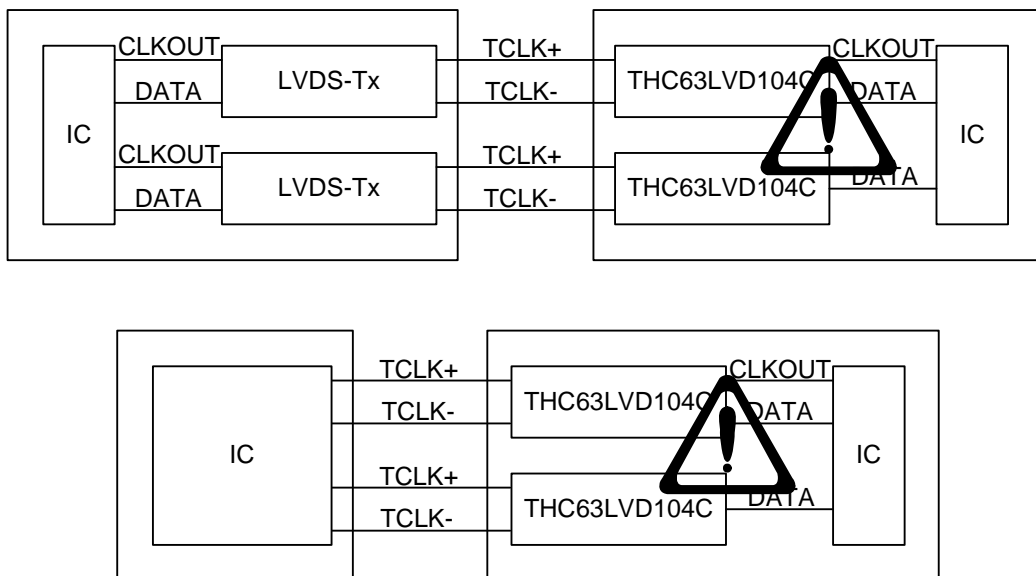

Package

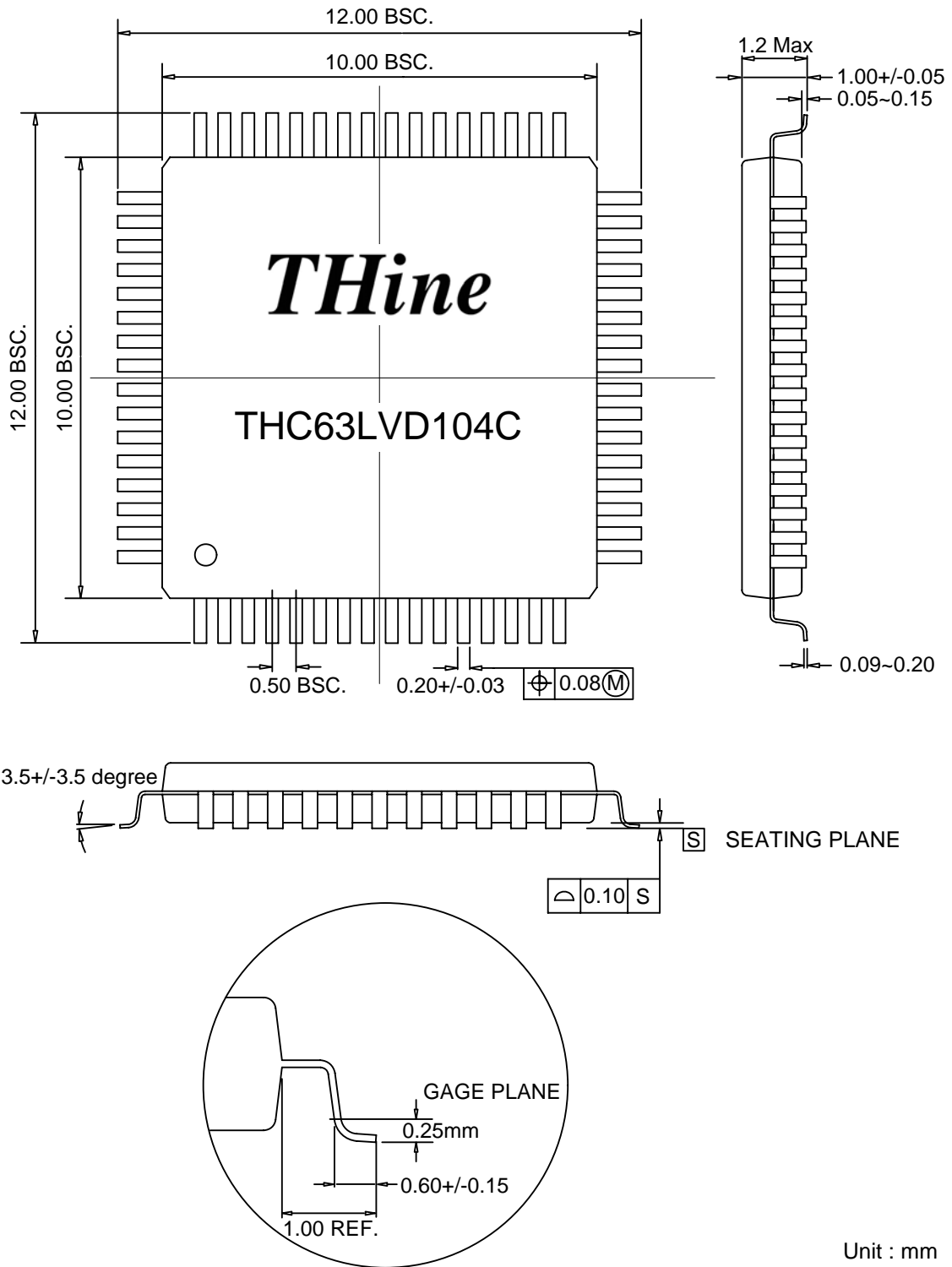

Unit : mm

Notices and Requests

1. The product specifications described in this material are subject to change without prior notice.
2. The circuit diagrams described in this material are examples of the application which may not always apply to the customer's design. We are not responsible for possible errors and omissions in this material. Please note if errors or omissions should be found in this material, we may not be able to correct them immediately.
3. This material contains our copy right, know-how or other proprietary. Copying or disclosing to third parties the contents of this material without our prior permission is prohibited.
4. Note that if infringement of any third party's industrial ownership should occur by using this product, we will be exempted from the responsibility unless it directly relates to the production process or functions of the product.
5. This product is presumed to be used for general electric equipment, not for the applications which require very high reliability (including medical equipment directly concerning people's life, aerospace equipment, or nuclear control equipment). Also, when using this product for the equipment concerned with the control and safety of the transportation means, the traffic signal equipment, or various Types of safety equipment, please do it after applying appropriate measures to the product.
6. Despite our utmost efforts to improve the quality and reliability of the product, faults will occur with a certain small probability, which is inevitable to a semi-conductor product. Therefore, you are encouraged to have sufficiently redundant or error preventive design applied to the use of the product so as not to have our product cause any social or public damage.
7. Please note that this product is not designed to be radiation-proof.
8. Customers are asked, if required, to judge by themselves if this product falls under the category of strategic goods under the Foreign Exchange and Foreign Trade Control Law.

THine Electronics, Inc.

E-mail: sales@thine.co.jp