

THC63LVDR84B

LVDS 24Bit COLOR HOST-LCD PANEL INTERFACE RECEIVER (Rising Edge Clock)

General Description

The THC63LVDR84B receiver supports wide VCC range(2.5~3.6V). At single 2.5V supply, the THC63LVDR84B reduces EMI and power consumption.

The THC63LVDR84B receiver convert the four LVDS(Low Voltage Differential Signaling) data streams back into 24bits of CMOS/TTL data with rising edge clock.

At a transmit clock frequency of 85MHz, 24bits of RGB data and 4bits of LCD timing and control data (HSYNC, VSYNC, CNTL1, CNTL2) are transmitted at a rate of 2.3Gbps.

Features

- Wide dot clock and Wide VCC range:

VCC[V]	Clock Frequency[MHz]		
	15 to 20	20 to 70	70 to 85
2.5 to 2.7	n/a	available	n/a
2.7 to 3.0	available	available	n/a
3.0 to 3.6	available	available	available

n/a : not available

- Rising Edge Clock
- PLL requires No external components
- Rx power consumption < 80mW @ VCC 2.5V, 65MHz Grayscale
- Power-Down Mode
- Low profile 56 Lead TSSOP Package
- Pin compatible with DS90CR286ATMD

Block Diagram

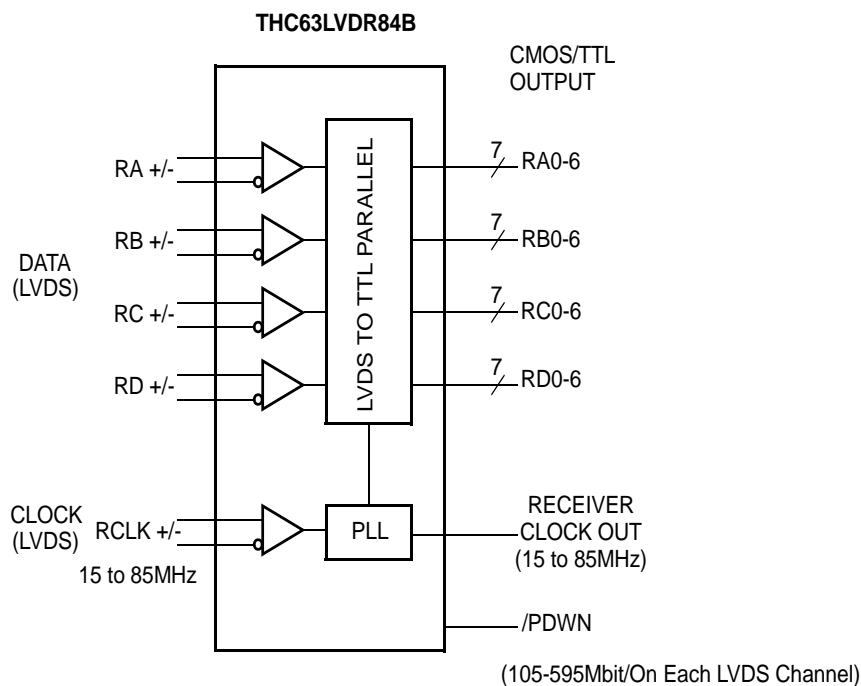

Pin Out

THC63LVDR84B			
RC3	1	56	VCC
RD6	2	55	RC2
RC4	3	54	RC1
GND	4	53	RC0
RC5	5	52	GND
RC6	6	51	RB6
RD0	7	50	RD5
LVDSGND	8	49	RD4
RA-	9	48	VCC
RA+	10	47	RB5
RB-	11	46	RB4
RB+	12	45	RB3
LVDSVCC	13	44	GND
LVDSGND	14	43	RB2
RC-	15	42	RD3
RC+	16	41	RD2
RCLK-	17	40	VCC
RCLK+	18	39	RB1
RD-	19	38	RB0
RD+	20	37	RA6
LVDSGND	21	36	GND
PLLGND	22	35	RA5
PLLVCC	23	34	RD1
PLLGND	24	33	RA4
/PDWN	25	32	RA3
CLKOUT	26	31	VCC
RA0	27	30	RA2
GND	28	29	RA1

Pin Description

Pin Name	Pin #	Type	Description
RA+, RA-	10, 9	LVDS IN	LVDS Data Inputs
RB+, RB-	12, 11	LVDS IN	
RC+, RC-	16, 15	LVDS IN	
RD+, RD-	20, 19	LVDS IN	
RCLK+, RCLK-	18, 17	LVDS IN	LVDS Clock Inputs
RA0~RA6	27,29,30,32,33,35,37	OUT	Pixel Data Outputs
RB0~RB6	38,39,43,45,46,47,51	OUT	
RC0~RC6	53,54,55,1,3,5,6	OUT	
RD0~RD6	7,34,41,42,49,50,2	OUT	
CLKOUT	26	OUT	Pixel Clock Output
/PDWN	25	IN	H: Normal operation L: Power down (all outputs are pulled to ground)
VCC	31,40,48,56	Power	Power Supply Pins for TTL outputs and digital circuitry
GND	4,28,36,44,52	Ground	Ground Pins for TTL outputs and digital circuitry
LVDSVCC	13	Power	Power Supply Pin for LVDS inputs
LVDSGND	8,14,21	Ground	Ground Pins for LVDS inputs
PLLVCC	23	Power	Power Supply Pin for PLL circuitry
PLLGND	22,24	Ground	Ground Pins for PLL circuitry

Absolute Maximum Ratings

Supply Voltage (V_{CC})	-0.3V ~ +4.0V
CMOS/TTL Input Voltage	-0.3V ~ ($V_{CC} + 0.3V$)
CMOS/TTL Output Voltage	-0.3V ~ ($V_{CC} + 0.3V$)
LVDS Receiver Input Voltage	-0.3V ~ ($V_{CC} + 0.3V$)
Junction Temperature	+125°C
Storage Temperature Range	-55°C ~ +150°C
Reflow Peak Temperature / Time	+260°C / 10sec.
Maximum Power Dissipation @+25°C	1.9W

Recommended Operating Conditions

Parameter		Min.	Max.	Units
All Supply Voltage		2.5	3.6	V
Operating Ambient Temperature		-10	70	°C
Clock Frequency	$V_{CC}=2.5V$ to $2.7V$	20	70	MHz
	$V_{CC}=2.7V$ to $3.0V$	15	70	MHz
	$V_{CC}=3.0V$ to $3.6V$	15	85	MHz

Electrical Characteristics

CMOS/TTL DC SPECIFICATIONS

 $V_{CC} = V_{CC} = PV_{CC} = LV_{CC}$

Symbol	Parameter	Conditions	Min.	Typ.	Max.	Units
V_{IH}	High Level Input Voltage		2.0		V_{CC}	V
V_{IL}	Low Level Input Voltage		GND		0.8	V
V_{OH1}	High Level Output Voltage	$V_{CC}= 3.0V \sim 3.6V$ $I_{OH} = -4mA$	2.4			V
V_{OL1}	Low Level Output Voltage	$V_{CC} = 3.0V \sim 3.6V$ $I_{OL} = 4mA$			0.4	V
V_{OH2}	High Level Output Voltage	$V_{CC}= 2.5V \sim 3.0V$ $I_{OH} = -2mA$	2.1			V
V_{OL2}	Low Level Output Voltage	$V_{CC} = 2.5V \sim 3.0V$ $I_{OL} = 2mA$			0.4	V
I_{IN}	Input Current	$0V \leq V_{IN} \leq V_{CC}$			± 10	μA

LVDS RECEIVER DC SPECIFICATIONS

 $V_{CC} = V_{CC} = PV_{CC} = LV_{CC}$

Symbol	Parameter	Conditions	Min.	Typ.	Max.	Units
V_{TH}	Differential Input High Threshold	$V_{IC} = +1.2V$			100	mV
V_{TL}	Differential Input Low Threshold		-100			mV
I_{IN}	Input Current	$V_{IN} = +2.4V/0V$ $V_{CC} = 3.6V$			± 10	μA

Supply Current

V_{CC} = V_{CC} = PV_{CC} = LV_{CC}

Symbol	Parameter	Condition(*)	Typ.	Max.	Units	
I _{RCCG}	Receiver Supply Current 16Grayscale Pattern	CL=8pF, VCC=3.3V	f = 65MHz	41	53	mA
			f = 85MHz	52	64	mA
		CL=8pF, VCC=2.5V	f = 65MHz	30	42	mA
			f = 65MHz	42	64	mA
I _{RCCW}	Receiver Supply Current Worst Case Pattern	CL=8pF, VCC=3.3V	f = 65MHz	72	94	mA
			f = 85MHz	84	96	mA
		CL=8pF, VCC=2.5V	f = 65MHz	42	64	mA
			f = 65MHz	42	64	mA
I _{RCCS}	Receiver Power Down Supply Current	/PDWN = L		10	μA	

16 Gray Scale Pattern

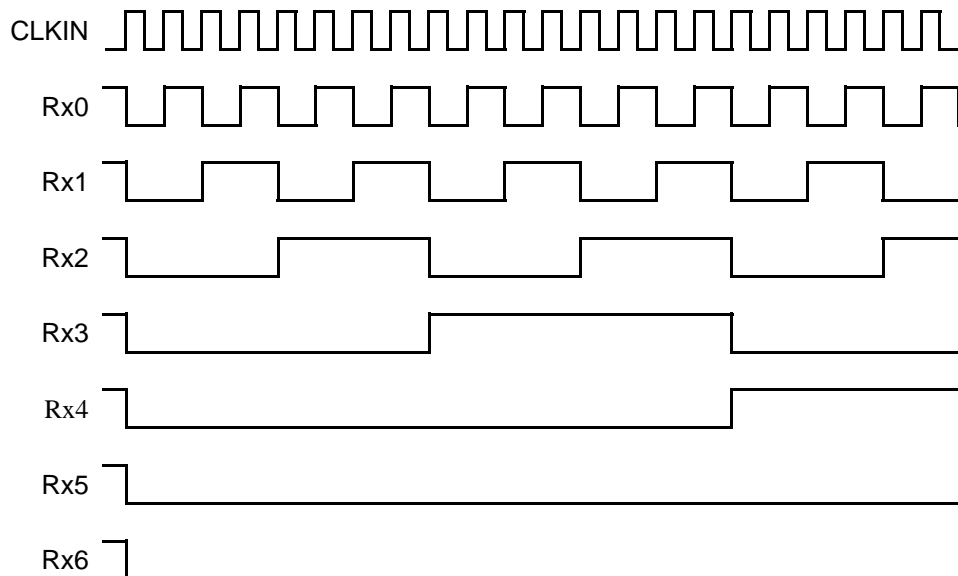

Worst Case Pattern

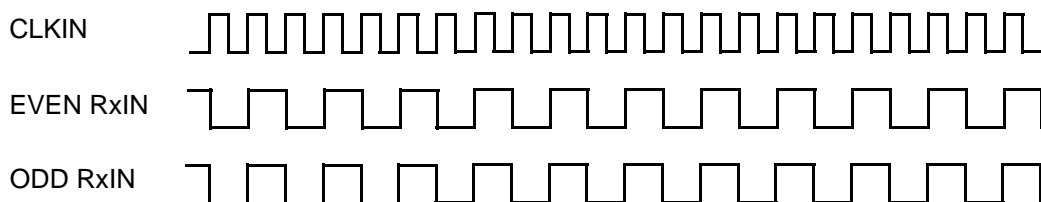

Switching Characteristics

V_{CC} = V_{CC} = PV_{CC} = LV_{CC}

Symbol	Parameter	Min.	Typ.	Max.	Units	
t _{RCP}	CLK OUT Period	V _{CC} = 2.5 - 2.7V	14.28	T	50.0	ns
		V _{CC} = 2.7 - 3.0V	14.28	T	66.6	ns
		V _{CC} = 3.0 - 3.6V	11.76	T	66.6	ns
t _{RCH}	CLK OUT High Time		3T/7		ns	
t _{RCL}	CLK OUT Low Time		4T/7		ns	
t _{RCD}	RCLK +/- to CLK OUT Delay		5T/7		ns	
t _{RS}	TTL Data Setup to CLK OUT	0.35T-0.3			ns	
t _{RH}	TTL Data Hold from CLK OUT	0.45T-1.6			ns	
t _{TLH}	TTL Low to High Transition Time		2.0	3.0	ns	
t _{THL}	TTL High to Low Transition Time		1.8	3.0	ns	
t _{RIP1}	Input Data Position0 (T = 11.76ns)	-0.4	0.0	0.4	ns	
t _{RIP0}	Input Data Position1 (T = 11.76ns)	T/7-0.4	T/7	T/7+0.4	ns	
t _{RIP6}	Input Data Position2 (T = 11.76ns)	2T/7-0.4	2T/7	2T/7+0.4	ns	
t _{RIP5}	Input Data Position3 (T = 11.76ns)	3T/7-0.4	3T/7	3T/7+0.4	ns	
t _{RIP4}	Input Data Position4 (T = 11.76ns)	4T/7-0.4	4T/7	4T/7+0.4	ns	
t _{RIP3}	Input Data Position5 (T = 11.76ns)	5T/7-0.4	5T/7	5T/7+0.4	ns	
t _{RIP2}	Input Data Position6 (T = 11.76ns)	6T/7-0.4	6T/7	6T/7+0.4	ns	
t _{RPLL}	Phase Lock Loop Set			10.0	ms	

AC Timing Diagrams

TTL Output

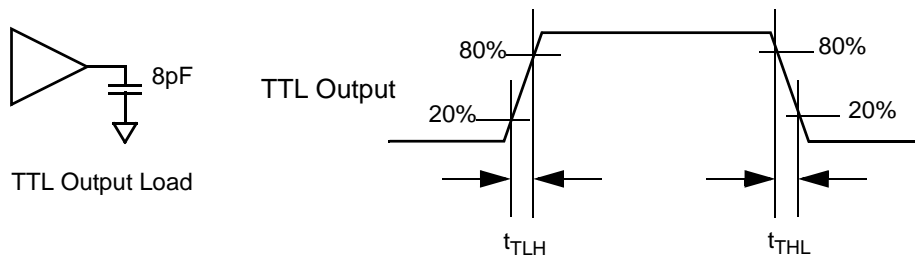

AC Timing Diagrams

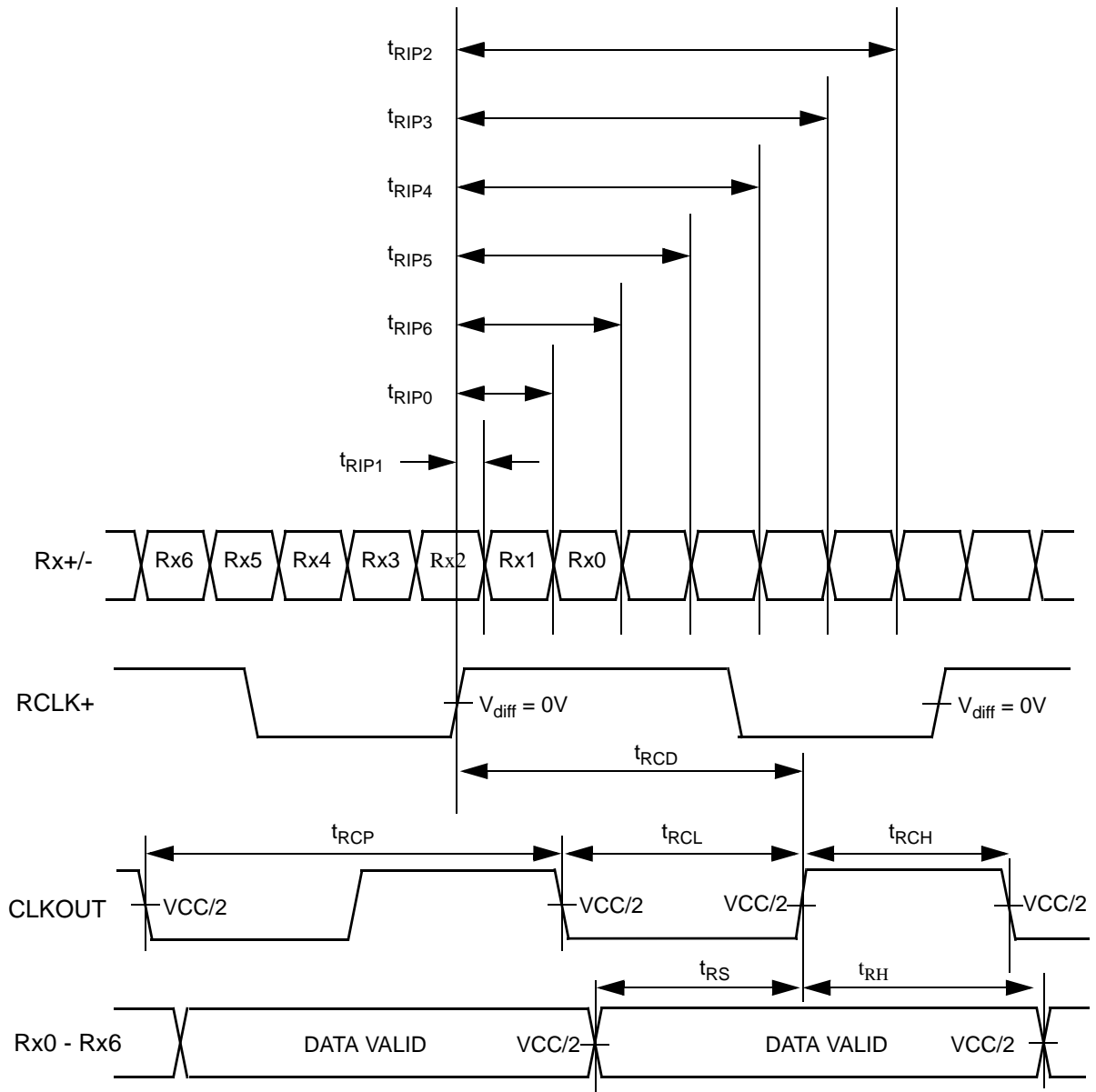

Note:
 1) $V_{diff} = (RA+) - (RA-), \dots, (RCLK+) - (RCLK-)$

AC Timing Diagrams

Phase Lock Loop Set Time

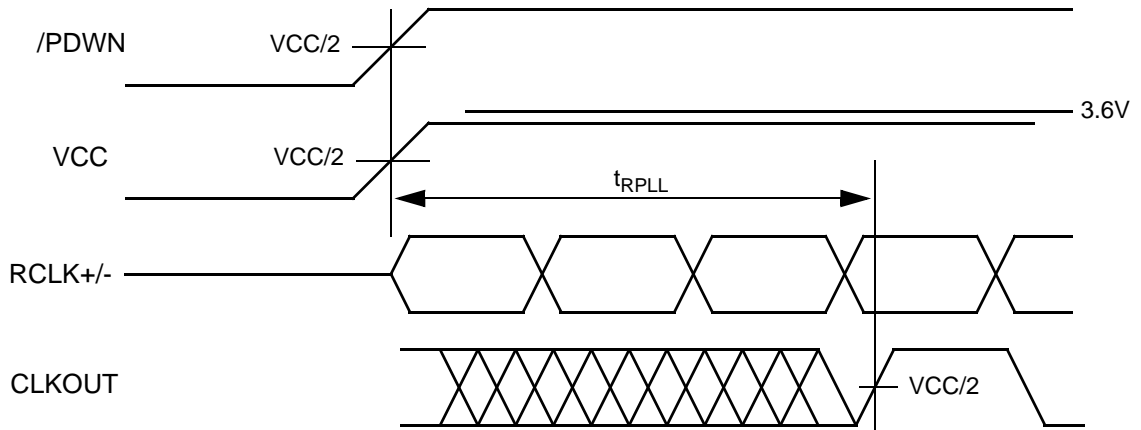

Note

1)Power On Sequence

Power on LVDS-Tx after THC63LVDR84B.

2)Cable Connection and Disconnection

Don't connect and disconnect the LVDS cable, when the power is supplied to the system.

3)GND Connection

Connect the each GND of the PCB which LVDS-Tx and THC63LVDR84B on it. It is better for EMI reduction to place GND cable as close to LVDS cable as possible.

4)Multi Drop Connection

Multi drop connection is not recommended.

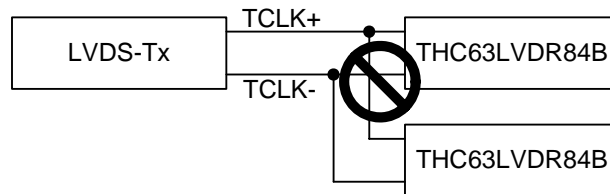

5)Asynchronous use

Asynchronous use such as following systems are not recommended.

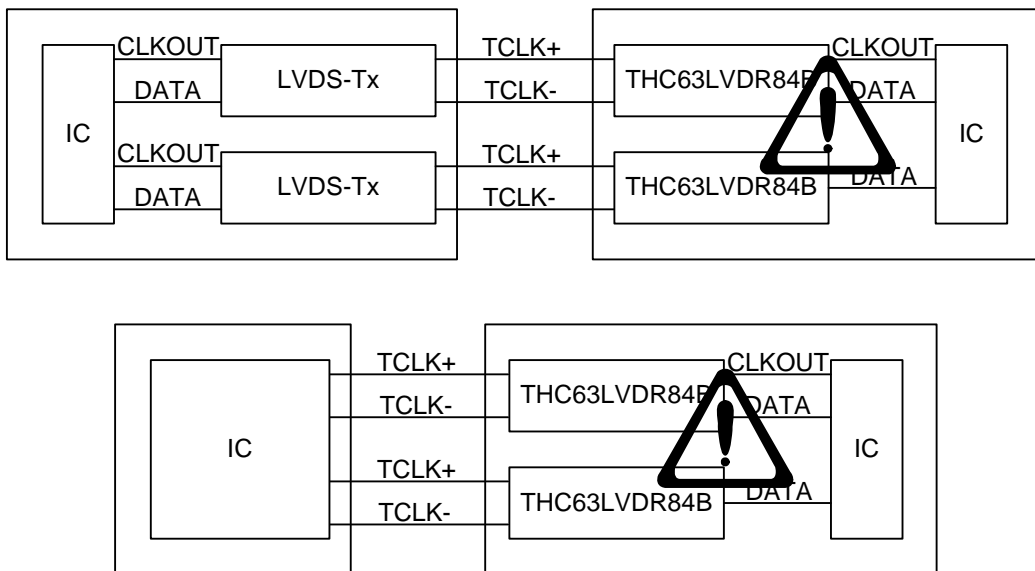

Package

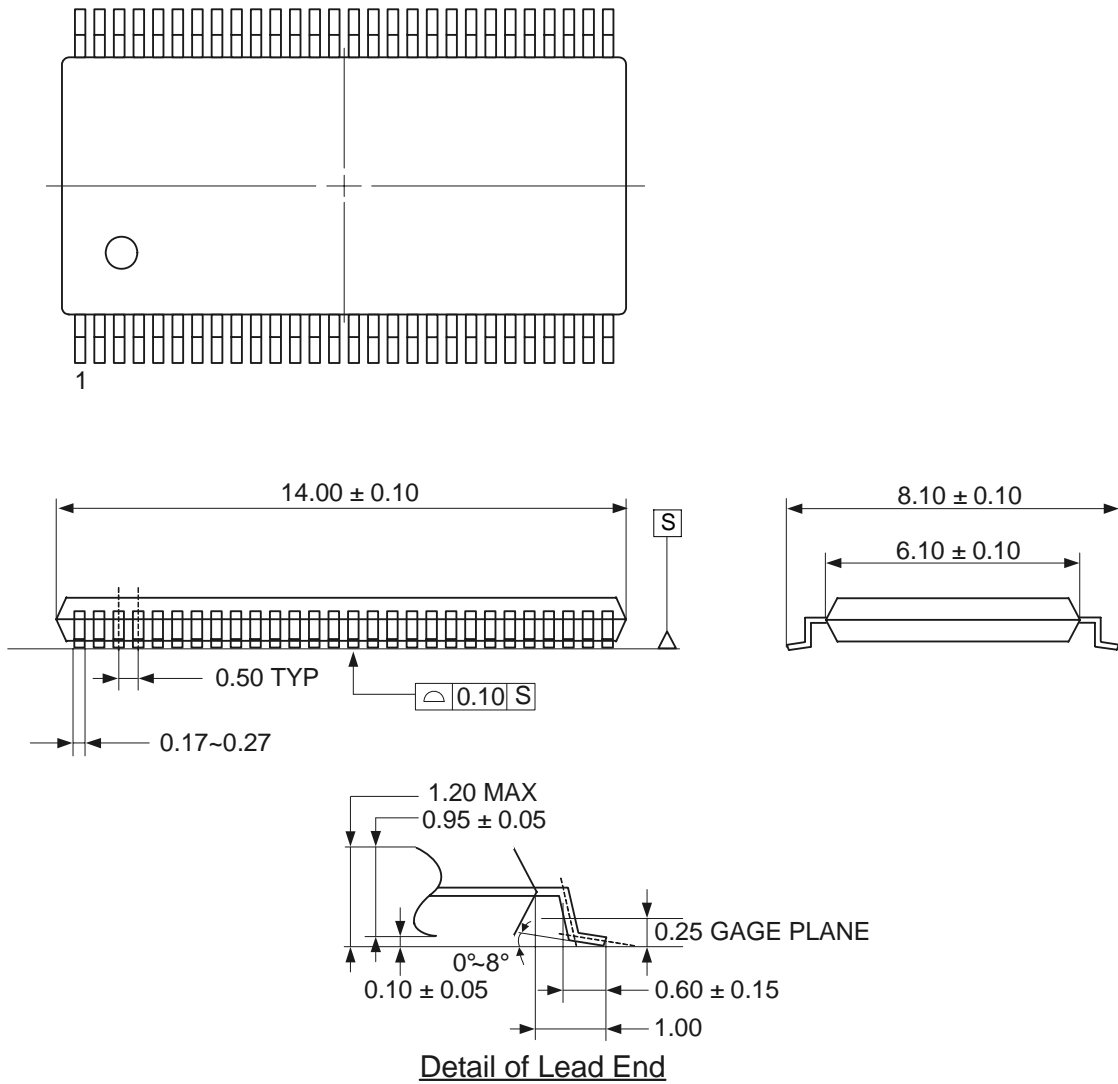

Unit:mm

Notices and Requests

1. The product specifications described in this material are subject to change without prior notice.
2. The circuit diagrams described in this material are examples of the application which may not always apply to the customer's design. We are not responsible for possible errors and omissions in this material. Please note if errors or omissions should be found in this material, we may not be able to correct them immediately.
3. This material contains our copy right, know-how or other proprietary. Copying or disclosing to third parties the contents of this material without our prior permission is prohibited.
4. Note that if infringement of any third party's industrial ownership should occur by using this product, we will be exempted from the responsibility unless it directly relates to the production process or functions of the product.
5. This product is presumed to be used for general electric equipment, not for the applications which require very high reliability (including medical equipment directly concerning people's life, aerospace equipment, or nuclear control equipment). Also, when using this product for the equipment concerned with the control and safety of the transportation means, the traffic signal equipment, or various Types of safety equipment, please do it after applying appropriate measures to the product.
6. Despite our utmost efforts to improve the quality and reliability of the product, faults will occur with a certain small probability, which is inevitable to a semi-conductor product. Therefore, you are encouraged to have sufficiently redundant or error preventive design applied to the use of the product so as not to have our product cause any social or public damage.
7. Please note that this product is not designed to be radiation-proof.
8. Customers are asked, if required, to judge by themselves if this product falls under the category of strategic goods under the Foreign Exchange and Foreign Trade Control Law.

THine Electronics, Inc.

E-mail: sales@thine.co.jp