

THC63LVDM87

LOW POWER / SMALL PACKAGE / 24Bit COLOR LVDS TRANSMITTER

General Description

The THC63LVDM87 transmitter is designed to support pixel data transmission between Host and Flat Panel Display up to 1080p/WUXGA resolutions.

The THC63LVDM87 converts 28bits of CMOS/TTL data into LVDS(Low Voltage Differential Signaling) data stream. The transmitter can be programmed for rising edge or falling edge clocks through a dedicated pin. At a transmit clock frequency of 160MHz, 24bits of RGB data and 4bits of timing and control data (HSYNC, VSYNC, DE, CONT1) are transmitted at an effective rate of 1120Mbps per LVDS channel.

Features

- Low power 1.8V CMOS design
- 5mm x 5mm/49pin/0.65mm pitch VFBGA Package applicable to non-HDI PCB
- Wide dot clock range, 8-160MHz suited for
TV Signal: NTSC(12.27MHz) - 1080p(148.5MHz)
PC Signal: QVGA(8MHz) - WUXGA(154MHz)
- Supports 1.8V single power supply
- 1.8V/2.5V/3.3V CMOS inputs are supported by setting IOVCC=1.8V/2.5V/3.3V
- LVDS swing is reducible by RS-pin to reduce EMI and power consumption
- PLL requires no external components
- Supports spread spectrum clock generator
- On chip jitter filtering
- Power down mode
- Input clock triggering edge is selectable by R/F-pin

Block Diagram

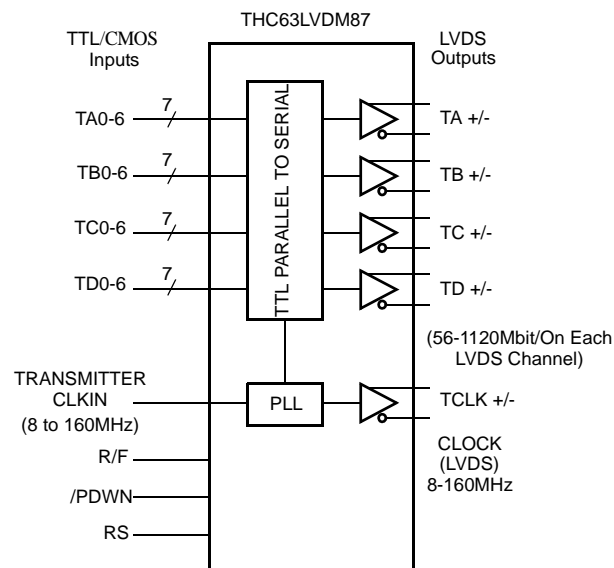

Pin Out

TOP VIEW

	1	2	3	4	5	6	7	
A	TA6	TA5	TA4	TA3	TA2	TA1	TA0	A
B	TB4	TD3	TD2	TD1	TD0	TA-	TA+	B
C	TB5	TB0	GND	VCC	RS	TB-	TB+	C
D	TB6	TB1	GND	IO VCC	LVDS VCC	TC-	TC+	D
E	TC0	TB2	GND	PLL VCC	R/F	TCLK-	TCLK+	E
F	TC1	TB3	TD4	TD5	TD6	TD-	TD+	F
G	TC2	TC3	TC4	TC5	TC6	CLKIN	/PDWN	G
	1	2	3	4	5	6	7	

Pin Description

Pin Name	Pin #	Type	Description						
TA+, TA-	B7, B6	LVDS OUT	LVDS Data Out.						
TB+, TB-	C7, C6	LVDS OUT							
TC+, TC-	D7, D6	LVDS OUT							
TD+, TD-	F7, F6	LVDS OUT							
TCLK+, TCLK-	E7, E6	LVDS OUT	LVDS Clock Out.						
TA0 ~ TA6	A7,A6,A5,A4,A3,A2,A1	IN	Pixel Data Inputs.						
TB0 ~ TB6	C2,D2,E2,F2,B1,C1,D1	IN							
TC0 ~ TC6	E1,F1,G1,G2,G3,G4,G5	IN							
TD0 ~ TD6	B5,B4,B3,B2,F3,F4,F5	IN							
/PDWN	G7	IN	H: Normal operation, L: Power down (All outputs are Hi-Z and all circuits are stand-by mode with minimum current(ITCCS))						
RS	C5	IN	LVDS swing mode select. <table border="1" data-bbox="948 920 1355 1032"> <thead> <tr> <th>RS</th> <th>LVDS Swing(VOD, see Fig4)</th> </tr> </thead> <tbody> <tr> <td>H</td> <td>350mV</td> </tr> <tr> <td>L</td> <td>200mV</td> </tr> </tbody> </table>	RS	LVDS Swing(VOD, see Fig4)	H	350mV	L	200mV
RS	LVDS Swing(VOD, see Fig4)								
H	350mV								
L	200mV								
R/F	E5	IN	Input Clock Triggering Edge Select. H: Rising edge, L: Falling edge						
CLKIN	G6	IN	Clock input.						
IO VCC	D4	Power	Power Supply Pin for IO Inputs.						
VCC	C4	Power	Power Supply Pin for digital circuitry.						
LVDS VCC	D5	Power	Power Supply Pin for LVDS Outputs.						
PLL VCC	E4	Power	Power Supply Pin for PLL circuitry.						
GND	C3,D3,E3	Ground	Ground Pins for Common.						

Absolute Maximum Ratings

Supply Voltage (IO VCC)	-0.3V ~ +4.0V
Supply Voltage (VCC, PLL VCC, LVDS VCC)	-0.3V ~ +2.1V
CMOS/TTL Input Voltage	-0.3V ~ (IO VCC + 0.3V)
LVDS Transmitter Output Voltage	-0.3V ~ (LVDS VCC + 0.3V)
LVDS Total Output Current	-50mA ~ 50mA
Junction Temperature (Tj)	+125°C
Storage Temperature Range	-55°C ~ +125°C
Reflow Peak Temperature / Time	+260°C / 10sec.
Maximum Power Dissipation @+25°C	1.3W

Recommended Operating Conditions

Parameter		Min.	Typ	Max	Units
Supply Voltage (IOVCC)		1.62	1.8/2.5/3.3	3.6	V
Supply Voltage (PLL VCC / LVDS VCC / VCC)		1.62	1.8	1.98	V
Operating Ambient Temperature (Ta)		-40		85	°C
Clock Frequency	Input	8		160	MHz
	LVDS Output	8		160	MHz

Electrical Characteristics

CMOS/TTL DC Specifications

Over recommended operating supply and temperature ranges unless otherwise specified.

Symbol	Parameter	Conditions	Min.	Typ.	Max.	Units
V_{IH18}	High Level Input Voltage	IOVCC=1.62~1.98V	0.65 IOVCC		IOVCC+0.3	V
V_{IL18}	Low Level Input Voltage		-0.3		0.35 IOVCC	V
V_{IH25}	High Level Input Voltage	IOVCC=2.3~2.7V	1.7		IOVCC+0.3	V
V_{IL25}	Low Level Input Voltage		-0.3		0.7	V
V_{IH33}	High Level Input Voltage	IOVCC=3.0~3.6V	2.0		IOVCC+0.3	V
V_{IL33}	Low Level Input Voltage		-0.3		0.8	V
I_{INC}	Input Current	VIN=GND~IOVCC	-10		10	μ A

LVDS Transmitter DC Specifications

Over recommended operating supply and temperature ranges unless otherwise specified.

Symbol	Parameter	Conditions	Min.	Typ.	Max.	Units	
VOD	Differential Output Voltage	RL=100 Ω	Normal swing RS=H	250	350	450	mV
			Reduced swing RS=L	140	200	300	mV
Δ VOD	Change in VOD between complementary output states	RL=100 Ω			35	mV	
VOC	Common Mode Voltage		1.125	1.25	1.375	V	
Δ VOC	Change in VOC between complementary output states				35	mV	
I_{OS}	Output Short Circuit Current	V_{OUT} =GND, RL=100 Ω			100	mA	
I_{OZ}	Output TRI-STATE Current	/PDWN=L, V_{OUT} =GND~LVDSVCC	-20		20	μ A	

Supply Current

Over recommended operating supply and temperature ranges unless otherwise specified.

Symbol	Parameter	Condition(*)			Typ.	Max.	Units
I _{TCCW}	Transmitter Supply Current	RL=100Ω CL=5pF	RS=H Normal swing mode	f=37MHz	25	33	mA
				f=71MHz	30	46	mA
				f=160MHz	44	79	mA
			RS=L Reduced swing mode	f=37MHz	19	27	mA
				f=71MHz	24	40	mA
				f=160MHz	38	73	mA
I _{TCCS}	Transmitter Power Down Supply Current	/PDWN = L, All Inputs = L or H			1	50	μA

(a) All Typ. values are at V_{cc}=1.8V, T_a=25°C . The 16 Grayscale Pattern (Fig1) inputs test for a typical display pattern.

(b) All Max. values are at V_{cc}=1.98V, T_a=85°C . LVDS Output Full Toggle Pattern (Fig2) produces maximum switching frequency for all the LVDS outputs.

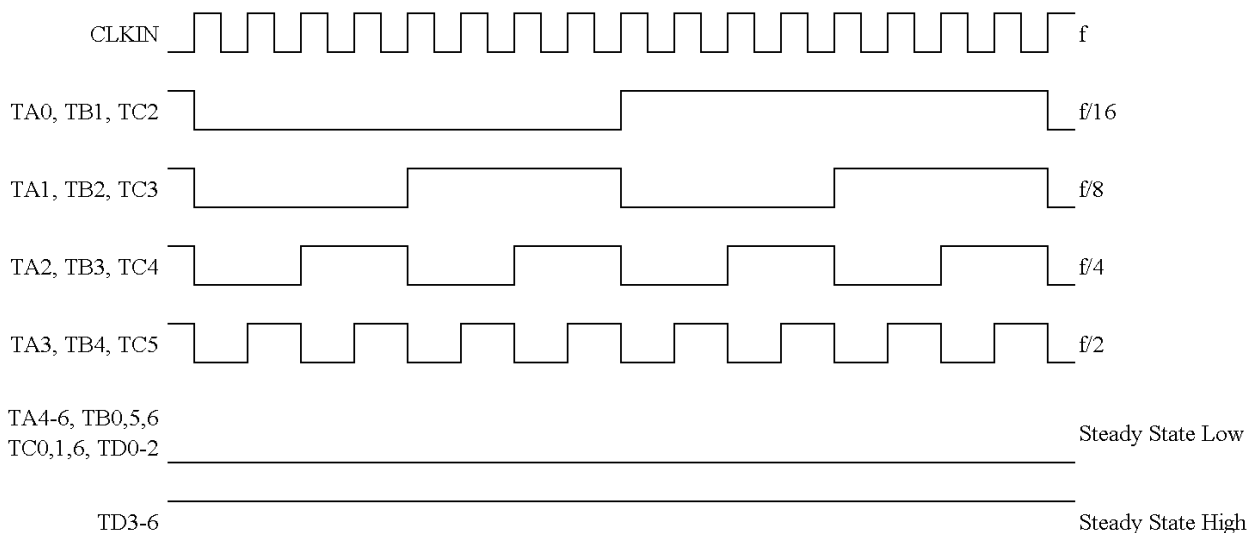

Fig1 16 Grayscale Pattern

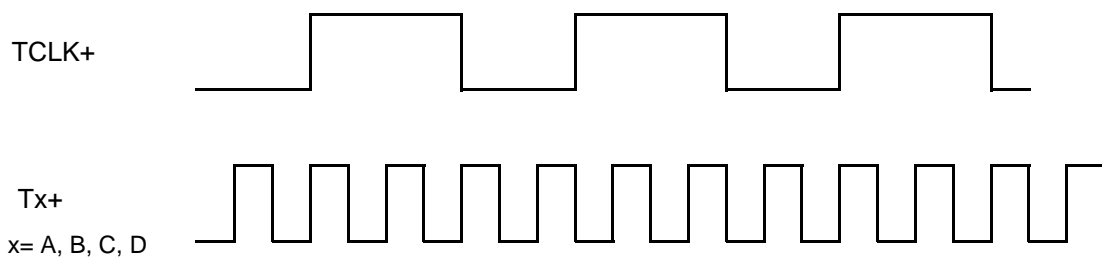

Fig2 LVDS Output Full Toggle Pattern

Switching Characteristics

Over recommended operating supply and temperature ranges unless otherwise specified.

Symbol	Parameter	Min.	Typ.	Max.	Units
t_{TCP}	CLK IN Period	6.25	T	125	ns
t_{TCH}	CLK IN High Time	0.35T	0.5T	0.65T	ns
t_{TCL}	CLK IN Low Time	0.35T	0.5T	0.65T	ns
t_{TCD}	CLK IN to TCLK+/- Delay (Fig4)	5T+3.1		5T+8	ns
t_{TS}	TTL Data Setup to CLK IN	0.8			ns
t_{TH}	TTL Data Hold from CLK IN	0.8			ns
t_{LVT}	LVDS Transition Time		0.6	1.5	ns
t_{TOP1}	Output Data Position0 (T=6.25ns~15ns)	-0.15	0.0	+0.15	ns
t_{TOP0}	Output Data Position1 (T=6.25ns~15ns)	$\frac{T}{7} - 0.15$	$\frac{T}{7}$	$\frac{T}{7} + 0.15$	ns
t_{TOP6}	Output Data Position2 (T=6.25ns~15ns)	$2\frac{T}{7} - 0.15$	$2\frac{T}{7}$	$2\frac{T}{7} + 0.15$	ns
t_{TOP5}	Output Data Position3 (T=6.25ns~15ns)	$3\frac{T}{7} - 0.15$	$3\frac{T}{7}$	$3\frac{T}{7} + 0.15$	ns
t_{TOP4}	Output Data Position4 (T=6.25ns~15ns)	$4\frac{T}{7} - 0.15$	$4\frac{T}{7}$	$4\frac{T}{7} + 0.15$	ns
t_{TOP3}	Output Data Position5 (T=6.25ns~15ns)	$5\frac{T}{7} - 0.15$	$5\frac{T}{7}$	$5\frac{T}{7} + 0.15$	ns
t_{TOP2}	Output Data Position6 (T=6.25ns~15ns)	$6\frac{T}{7} - 0.15$	$6\frac{T}{7}$	$6\frac{T}{7} + 0.15$	ns
t_{TPLL}	Phase Lock Loop Set			10.0	ms

AC Timing Diagrams

LVDS Output

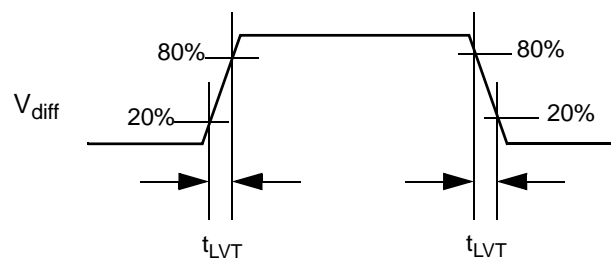
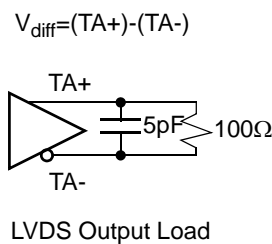

Fig3. LVDS Output Load and Transition Time

AC Timing Diagrams

TTL Inputs

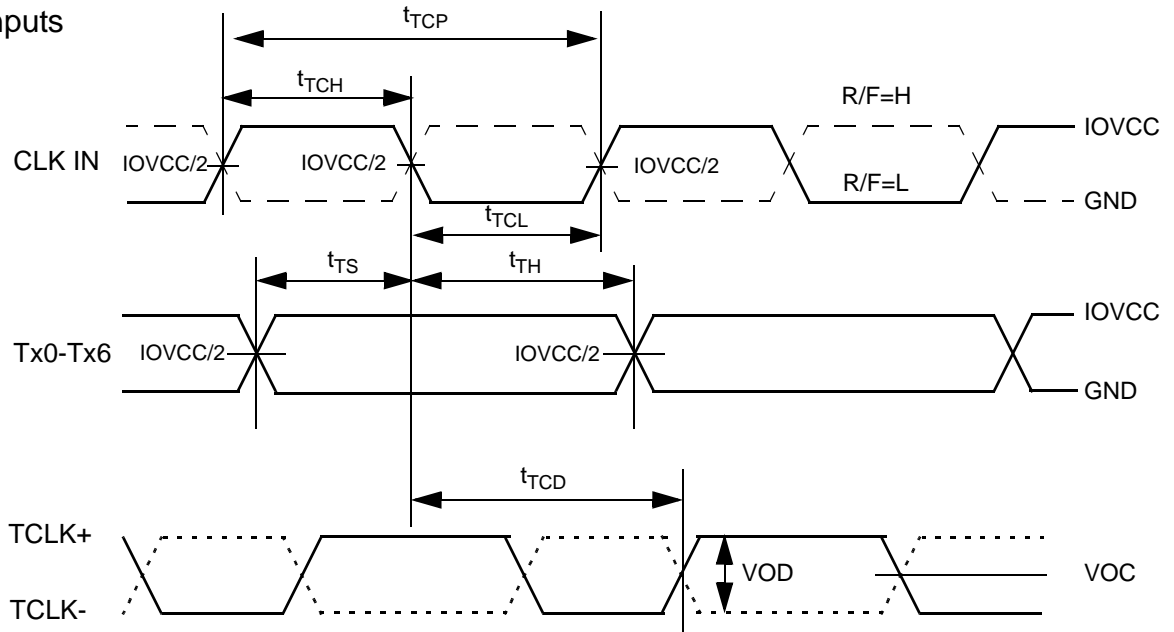

Fig4. CLKIN Period, High/Low Time, Setup/Hold Timing

AC Timing Diagrams

LVDS Output

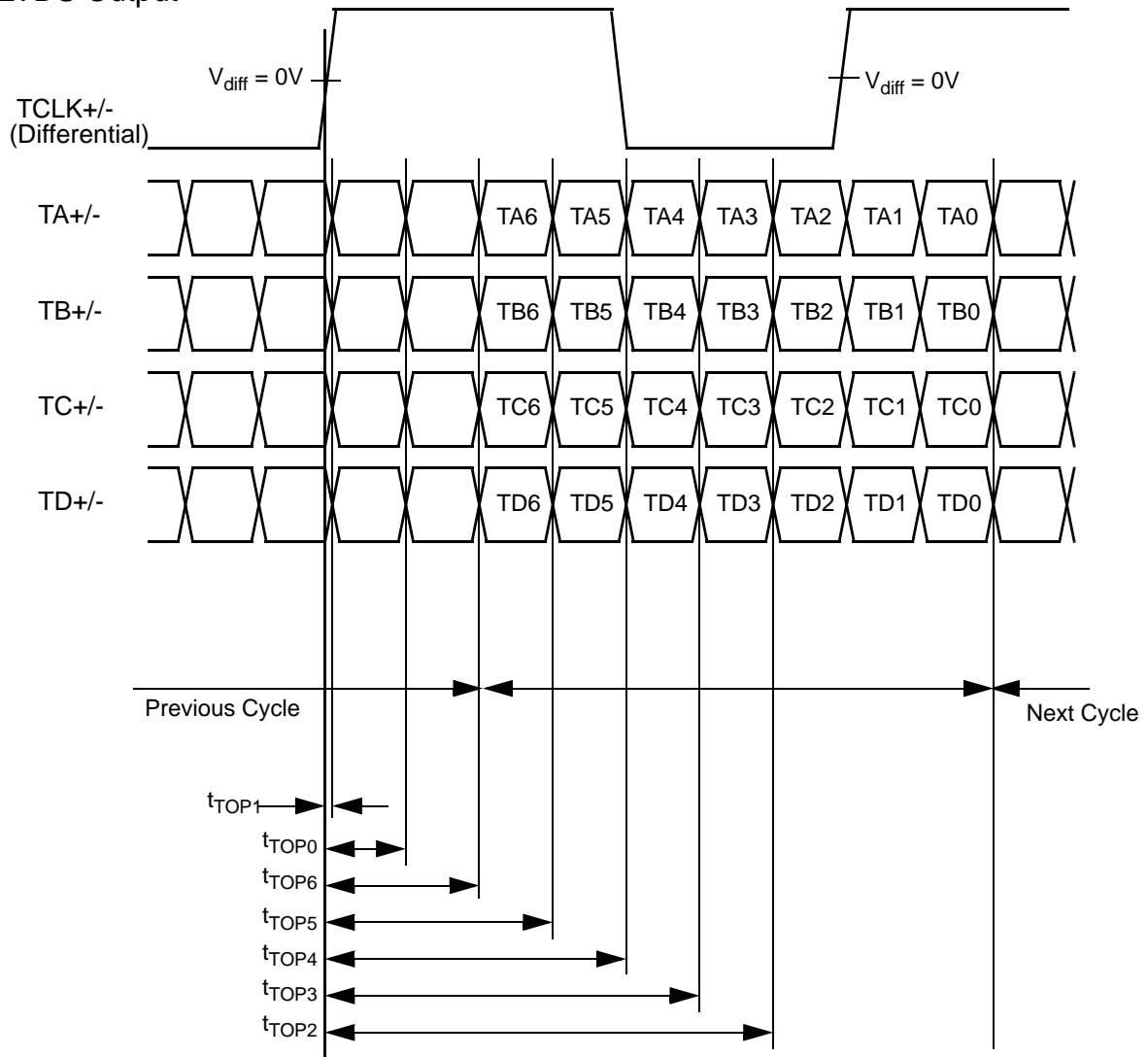

Fig5. LVDS Output Data Position

Phase Lock Loop Set Time

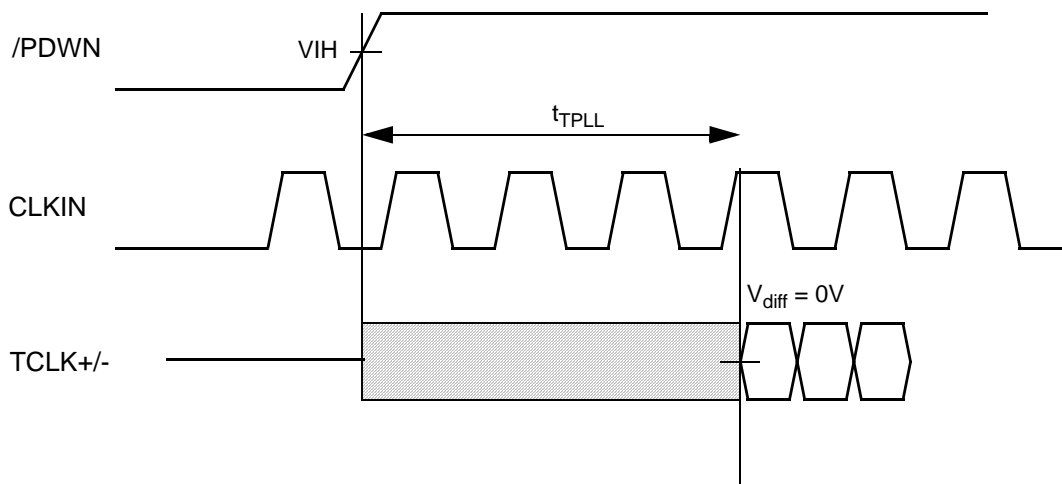

Fig6. PLL Lock Time

Note

1)Cable Connection and Disconnection

Don't connect and disconnect the LVDS cable, when the power is supplied to the system.

2)GND Connection

Connect the each GND of the PCB which THC63LVDM87 and LVDS-Rx on it. It is better for EMI reduction to place GND cable as close to LVDS cable as possible.

3)Multi Drop Connection

Multi drop connection is not recommended.

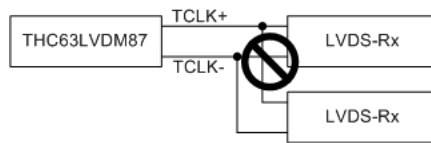

4)Asynchronous use

Asynchronous use such as following systems are not recommended.

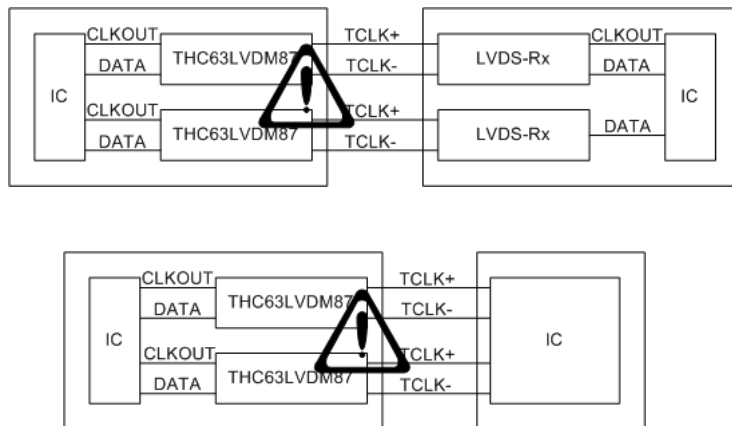

Package

VFBGA

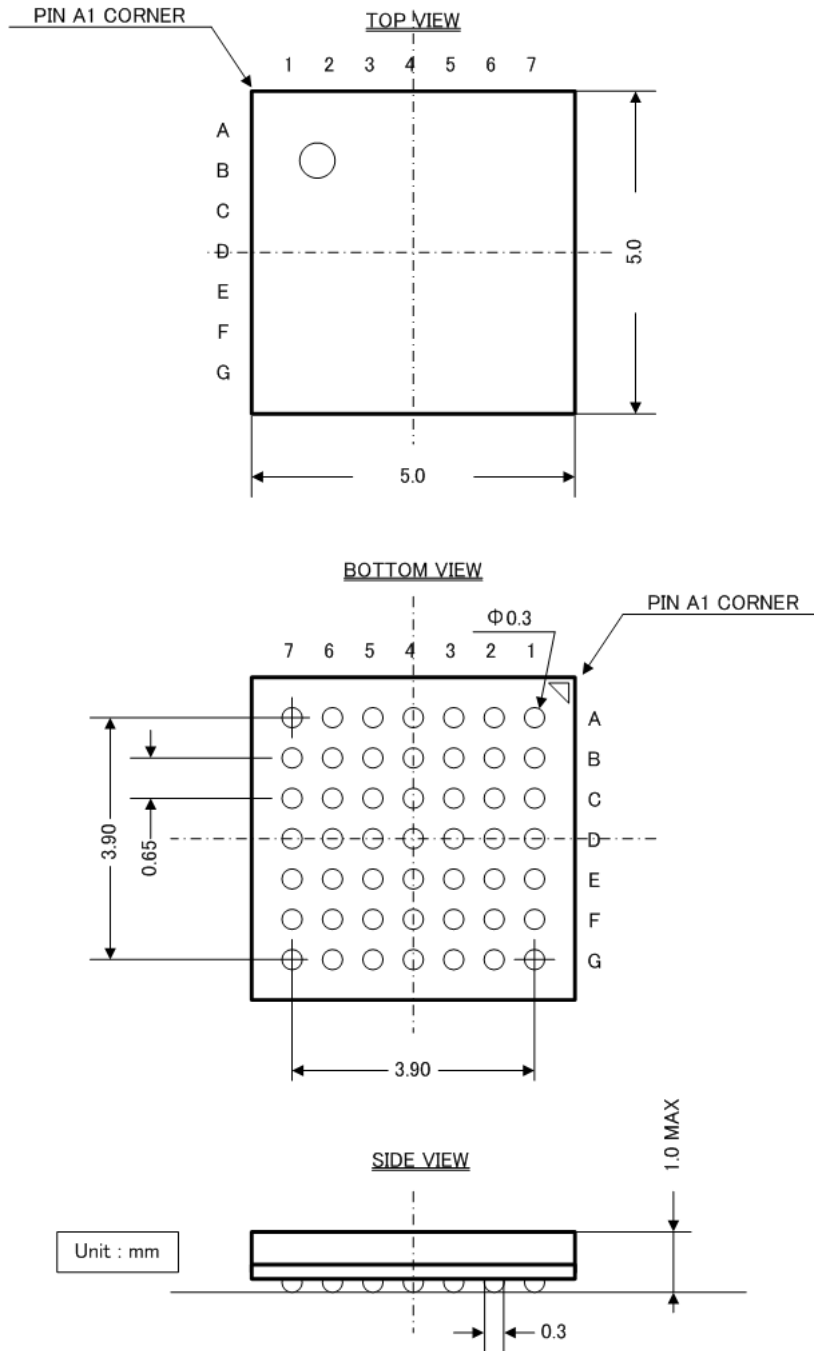

Notices and Requests

1. The product specifications described in this material are subject to change without prior notice.
2. The circuit diagrams described in this material are examples of the application which may not always apply to the customer's design. We are not responsible for possible errors and omissions in this material. Please note if errors or omissions should be found in this material, we may not be able to correct them immediately.
3. This material contains our copyright, know-how or other proprietary. Copying or disclosing to third parties the contents of this material without our prior permission is prohibited.
4. Note that if infringement of any third party's industrial ownership should occur by using this product, we will be exempted from the responsibility unless it directly relates to the production process or functions of the product.
5. This product is presumed to be used for general electric equipment, not for the applications which require very high reliability (including medical equipment directly concerning people's life, aerospace equipment, or nuclear control equipment). Also, when using this product for the equipment concerned with the control and safety of the transportation means, the traffic signal equipment, or various Types of safety equipment, please do it after applying appropriate measures to the product.
6. Despite our utmost efforts to improve the quality and reliability of the product, faults will occur with a certain small probability, which is inevitable to a semi-conductor product. Therefore, you are encouraged to have sufficiently redundant or error preventive design applied to the use of the product so as not to have our product cause any social or public damage.
7. Please note that this product is not designed to be radiation-proof.
8. Customers are asked, if required, to judge by themselves if this product falls under the category of strategic goods under the Foreign Exchange and Foreign Trade Control Law.