

THL6518

8 channels LED Driver

Description

THL6518 is a 8 channels LED driver. THL6518 has a built-in boost converter, since back light system can consist of 1 chip.

Soft start / Over current protection / Vout short circuit protection / Under voltage protection / Over voltage protection / Thermal shut down are built in.

Mounted area is reducible by 16-pin QFN.

Application

- Mobile phone display backlight
- Car Navigator display backlight
- Laptop/Netbook/Tablet PC display backlight

Features

- Input voltage range : 2.7V - 24V
- Boost converter
 - Maximum output voltage : 40V
 - Switching frequency : 1MHz
- LED driver
 - Up to 60mA per channel
 - Current accuracy : +/-3%
- PWM dimming control
- Protection
 - Soft start
 - Over current protection
 - Vout short circuit protection
 - Under voltage protection
 - Over voltage protection
 - Thermal shut down
- 3mm x 3mm QFN 16pin package

Block Diagram

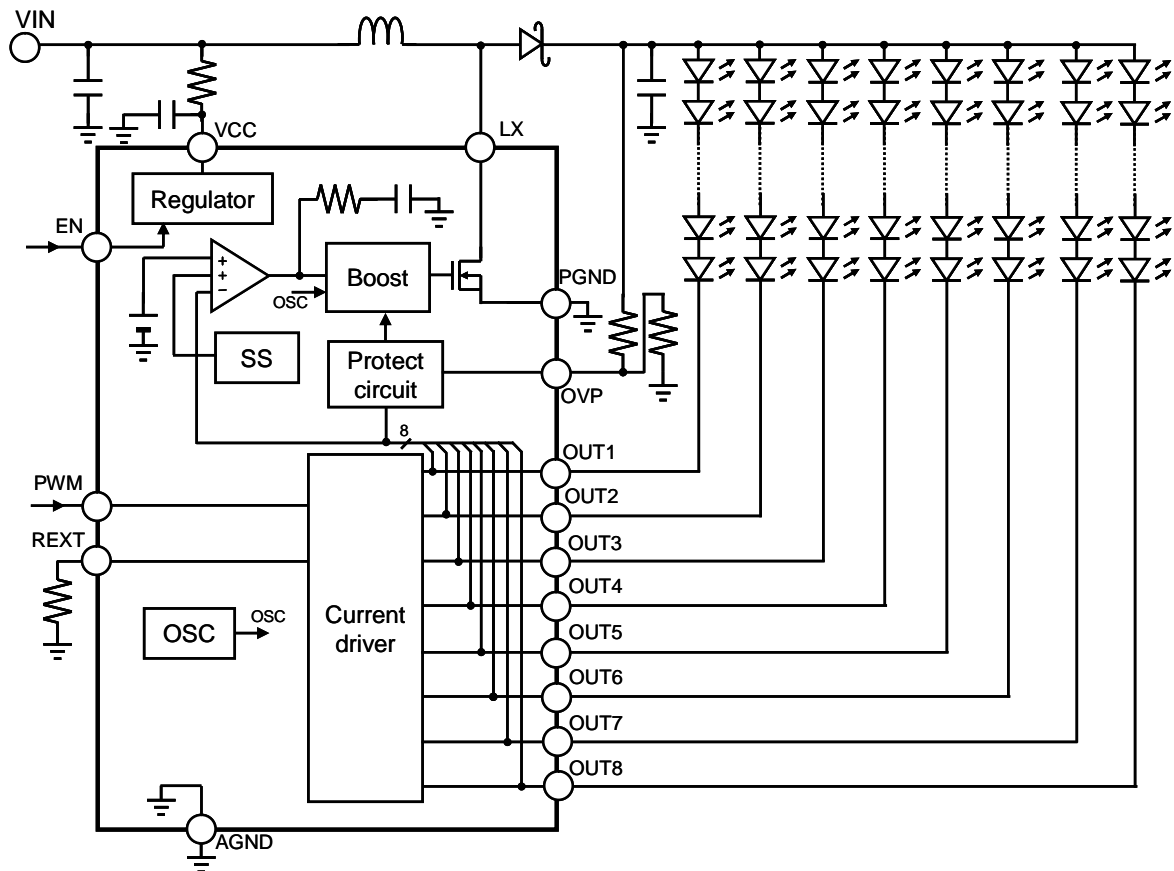

Absolute Maximum Ratings

Parameter	Symbol	Rating	Units
VCC voltage	VCC	27	V
LX voltage	VH1	45	V
OUT[8:1] voltage	VH2	40	V
EN, PWM voltage	VL	27	V
Power rating	Pd	1.67	W
Junction temperature	Tj	125	°C
Storage temperature range	Tstg	-55 ~ +150	°C

Recommended Operating Conditions

Parameter	Min	Typ	Max	Units
VCC voltage	2.7	-	24	V
OUT[8:1] voltage	-	-	40	V

Pin Description

Number	Name	Function	Description
1	PGND	Power ground.	Power ground pins of boost converter
2	LX	Boost converter error amplifier output pin.	This pin is switching output of boost converter.
3	VCC	Input supply voltage pin.	Power supply pin.
4	OVP	Over voltage protection input pin.	This pin is the over voltage protection circuit setting input of the boost converter for LED driver. This pin is controlled by external resistance.
5	REXT	LED current control pin.	LED current is set by the value of the external resistor.
6, 7, 8, 9	OUT1 to OUT3	LED current sink regulation input pins.	These pins are the constant current output. The constant current is determined by REXT resistor.
10	AGND	Analog ground	Analog ground of LED driver.
11	PWM	PWM dimming control input pin.	This pin is control input to LED dimming.
12, 13, 14, 15	OUT4 to OUT6	LED current sink regulation input pins.	These pins are the constant current output. The constant current is determined by REXT resistor.
16	EN	Enable pin.	If low level voltage is impressed, the LED driver is shutdown.

Electrical Characteristics (at VCC=12V, Ta=25°C, unless otherwise noted)

Parameter	Symbol	Test Conditions	Min	Typ	Max	Units
Input quiescent current	Icc1	EN>1.9V, switching	-	2	3	mA
Standby current	Ist	EN<0.8V	-	2	18	uA
UVLO threshold voltage	Vuvlo	VCC rising	2.4	2.5	2.6	V
UVLO hysteresis voltage	dVuvloh		-	0.15	-	V
PWM dimming frequency	Fpwm		0.1	-	30	kHz
PWM input high voltage	Vpwm_h		1.9	-	-	V
PWM input low voltage	Vpwm_l		-	-	0.8	V
Boost converter switching frequency	Fosc		0.9	1	1.2	MHz
Maximum duty cycle	Dmax		-	94	-	%
Minimum duty cycle	Dmin		-	-	7	%
LX ON-resistance	Ron		-	0.2	0.45	Ω
LX current limit	Ilim		2	2.5	3	A
OUTx LED current	Iled_max	VCC>2.7V, CHx>0.7V	30	-	-	mA
		VCC>4.5V, CHx>1V	60	-	-	
OUTx pin leakage current	Ileak	VOU=36V	-	-	3	uA
REXT pin voltage	Vrext		1.204	1.229	1.253	V
LED current accuracy	Iled	Irext = 20 uA	19.4	20.0	20.6	mA
LED current matching	Dled		-	1	2.5	%
Over voltage protection threshold	Vovp		1.198	1.229	1.260	V
LED short protection	Vled_s		7.2	8	8.8	V

Package Dimension

QFN 16-pin

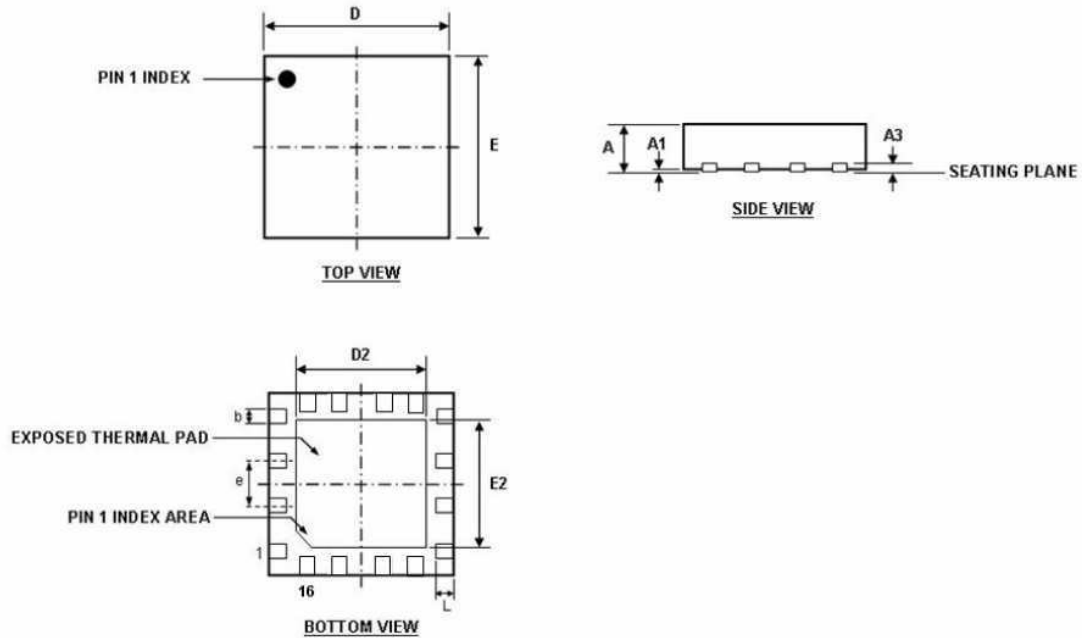

DIMENSION	MIN (mm)	MAX (mm)
A	0.70	0.80
A1	0.00	0.05
A3	0.20 REF	
b	0.18	0.30
D	3.00 BSC	
D2	1.60	1.80
E	3.00 BSC	
E2	1.60	1.80
e	0.50 BSC	
L	0.30	0.45

Notes:

1) All dimensions are in millimeters.

Connect the Exposed Pad to GND for enhanced thermal performance.

Notices and Requests

1. The product specifications described in this material are subject to change without prior notice.
2. The circuit diagrams described in this material are examples of the application which may not always apply to the customer's design. We are not responsible for possible errors and omissions in this material. Please note if errors or omissions should be found in this material, we may not be able to correct them immediately.
3. This material contains our copyright, know-how or other proprietary. Copying or disclosing to third parties the contents of this material without our prior permission is prohibited.
4. Note that if infringement of any third party's industrial ownership should occur by using this product, we will be exempted from the responsibility unless it directly relates to the production process or functions of the product.
5. This product is presumed to be used for general electric equipment, not for the applications which require very high reliability (including medical equipment directly concerning people's life, aerospace equipment, or nuclear control equipment). Also, when using this product for the equipment concerned with the control and safety of the transportation means, the traffic signal equipment, or various Types of safety equipment, please do it after applying appropriate measures to the product.
6. Despite our utmost efforts to improve the quality and reliability of the product, faults will occur with a certain small probability, which is inevitable to a semi-conductor product. Therefore, you are encouraged to have sufficiently redundant or error preventive design applied to the use of the product so as not to have our product cause any social or public damage.
7. Please note that this product is not designed to be radiation-proof.
8. Customers are asked, if required, to judge by themselves if this product falls under the category of strategic goods under the Foreign Exchange and Foreign Trade Control Law.
9. The product or peripheral parts may be damaged by a surge in voltage over the absolute maximum ratings or malfunction, if pins of the product are shorted by such as foreign substance. The damages may cause a smoking and ignition. Therefore, you are encouraged to implement safety measures by adding protection devices, such as fuses.

THine Electronics, Inc.

sales@thine.co.jp