

THL3501

16-channel LED Driver with LVDS Interface

Descriptions

The THL3501 is an LED driver with 16 channel open-drain outputs.

The embedded oscillator and PWM controller individually generates 256-step brightness set by the dedicated registers for each channel.

The serial interface of 2-pair LVDS lines (clock and data) features high-level noise tolerance, high-speed, and long-distance transmission.

The LVDS allowing cascaded and multidrop connection offers the maximum flexibility for designers to place and connect LED drivers.

The simple and one-way communication protocol is easily-controlled and requires less CPU resources.

Applications

- Amusement
- LED Backlight
- LED Display
- Digital Signage
- Illumination

Features

< Driver part >

- Open-Drain Output: 16 channels
- Output Sink Current: up to 100mA/ch
- Output voltage: up to 40V
- Individual Brightness Control: 256 steps
- Group Brightness Control: 64 steps
- Output disable/enable

< Serial interface part >

- 2-pair Serial LVDS Input or 3-wire Serial CMOS Input up to 10Mbps
- Bridge Function Converting 3-wire Serial CMOS Input to 2-pair Serial LVDS Output
- Repeater function of 2-pair Serial LVDS Input / Output with Waveform and Timing Correction
- Device Address Selection up to 62 addresses
- General call to all devices

Protection Circuits

UVLO, Overcurrent Protection, Thermal Shutdown

Supply Voltage: 3.0~5.5V

Package: QFN 40-pin Exposed Pad

Block Diagram

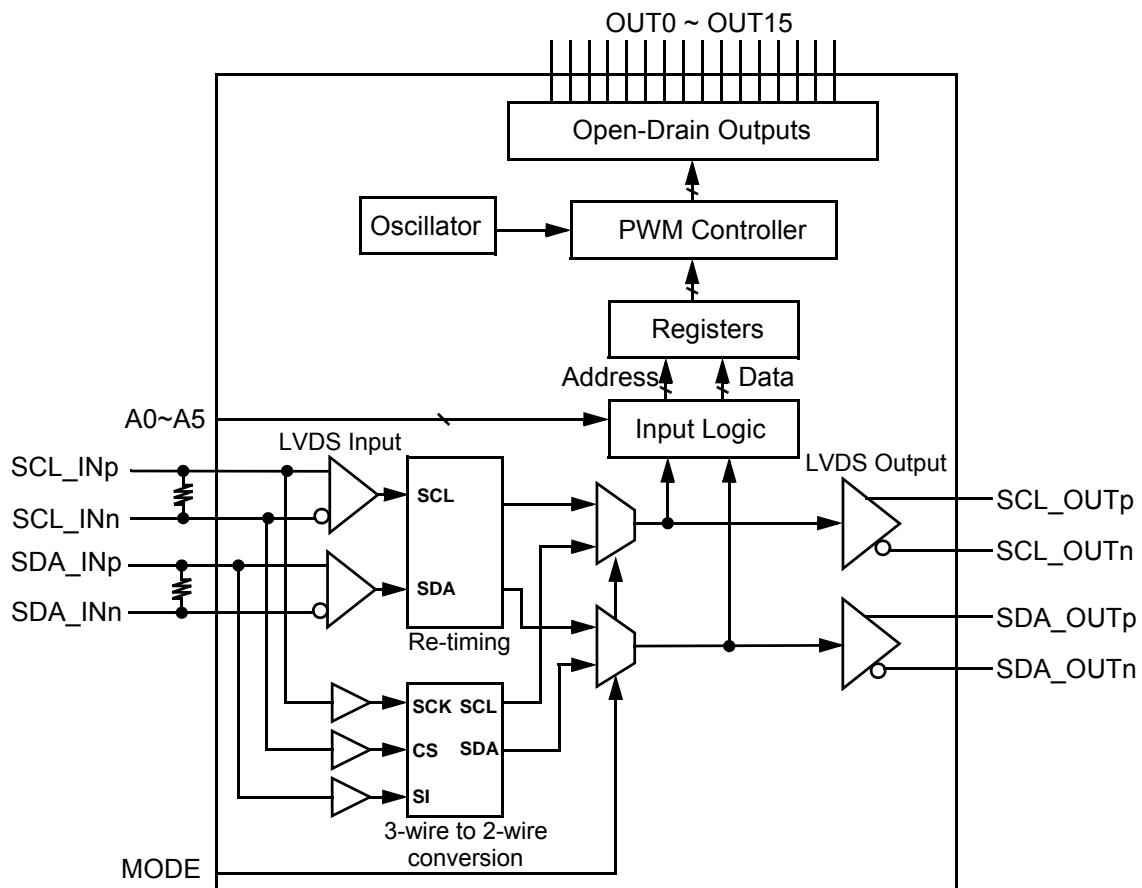

Notices and Requests

1. The product specifications described in this material are subject to change without prior notice.
2. The circuit diagrams described in this material are examples of the application which may not always apply to the customer's design. We are not responsible for possible errors and omissions in this material. Please note if errors or omissions should be found in this material, we may not be able to correct them immediately.
3. This material contains our copy right, know-how or other proprietary. Copying or disclosing to third parties the contents of this material without our prior permission is prohibited.
4. Note that if infringement of any third party's industrial ownership should occur by using this product, we will be exempted from the responsibility unless it directly relates to the production process or functions of the product.
5. This product is presumed to be used for general electric equipment, not for the applications which require very high reliability (including medical equipment directly concerning people's life, aerospace equipment, or nuclear control equipment). Also, when using this product for the equipment concerned with the control and safety of the transportation means, the traffic signal equipment, or various Types of safety equipment, please do it after applying appropriate measures to the product.
6. Despite our utmost efforts to improve the quality and reliability of the product, faults will occur with a certain small probability, which is inevitable to a semi-conductor product. Therefore, you are encouraged to have sufficiently redundant or error preventive design applied to the use of the product so as not to have our product cause any social or public damage.
7. Please note that this product is not designed to be radiation-proof.
8. Customers are asked, if required, to judge by themselves if this product falls under the category of strategic goods under the Foreign Exchange and Foreign Trade Control Law.

THine Electronics, Inc.

E-mail: sales@thine.co.jp