



SG0611

High-Temperature Instrumentation Amplifier With Sensor Supply

◆ DESCRIPTION

The SG0611 is an instrumentation amplifier designed for sensors working at high temperature with the electronics close to the heat sources.

The gain is programmable in more than 40 steps without external components.

A 5V voltage reference supplies the circuit and the sensor bridge. A high voltage pre-regulator is also included to increase the supply range.

The device is manufactured in an SOI process with very low leakage currents and a high-temperature metal system to guarantee continuous operation at high temperature.

◆ KEY FEATURES

- High-temperature operation up to **+225°C**
- Selectable gain from 18x to 278x in more than 40 steps without external components
- Pre-regulator with supply up to 36V
- Internal 5V reference and sensor supply
- No external high-temperature components needed
- Available as die
- Available in 6x6 mm CQFN package
- Option to customise for your application
- Evaluation board available

◆ TYPICAL APPLICATION

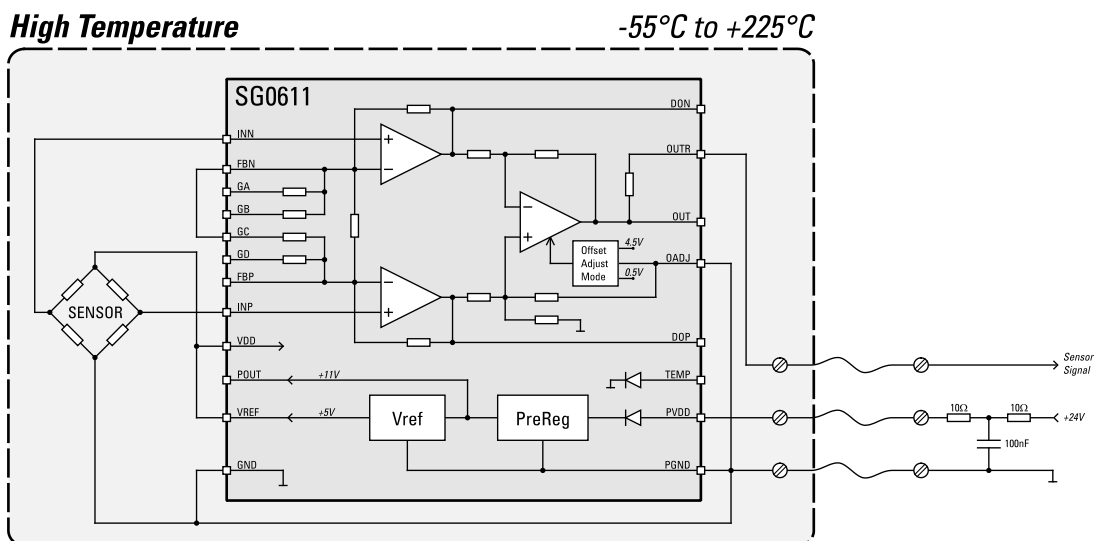



SG0611

◆ ORDERING INFORMATION

The product is available in the following packages and test options, see other section for more details:

Order Code	Package Type	Packaging	Package Quantity	Brief description of Test Option
SG0611/X/N1	Die	Tray	100	Sample test in +225°C
SG0611/G/N1	24-pin CERDIP	Stick	15	100% test in +25°C, sample test in +225°C
SG0611/G/N4	24-pin CERDIP	Stick	15	100% test in +225°C
SG0611/G/N8	24-pin CERDIP	Stick	15	100% test in +225°C, Burn-in 160h
SG0611/V/N1	20-pin CQFN	Tray	25	100% test in +25°C, sample test in +225°C

Contact SGA for information about non-standard versions.

The SG0611 Instrumentation Amplifier is also available on the following boards that can be used for demonstration or evaluation purposes. They are both designed to handle temperatures up to +225°C:

Order Code	Board Type	Package used	Description
SG0614	Amplifier module	CQFN	Miniature demonstrator 7.5 x 14.5 mm
SG0611/E2	Evaluation board	CERDIP	SG0611 Evaluation board for +225°C

For more information about these boards, see separate data sheets.

◆ ABSOLUTE MAXIMUM RATINGS

Parameter	Value
Supply voltage (PVDD)	40V
VDD supply voltage	6V
Supply voltage (POUT)	25V
Power dissipation	500mW
Voltage on all signal pins	-0.5V to VDD+0.5V
Ambient temperature, Ta	+300°C

Stresses above these ratings may cause permanent damage. Exposure to absolute maximum ratings for extended periods may degrade device reliability.

See section Application Information for protection against transients and ESD.



SG0611

◆ ELECTRICAL CHARACTERISTICS

Connections according to Typical Application Diagram unless otherwise specified. PVDD=+24V. No external components. All gain select links open. OADJ=0V. Tj=-55°C to +225°C.

Parameter Amplifiers	Conditions	Min	Typ	Max	Unit
Input offset	@+25°C			±3	mV
Input offset drift			< 2	±10	μV/°C
Gain tolerance	@+25°C, See gain settings table			±1	%
Gain drift				±30	ppm/°C
Linearity	Gain=18x			±0.5	mV
Bandwidth	@+25°C, On OUT, Gain=18x		80		kHz
Bandwidth	@+25°C, On OUT, Gain=278x		12		kHz
Output noise, OUT	@+25°C, Gain=18x		0.2		mVrms
Output noise, OUT	@+25°C, Gain=278x		1.5		mVrms
Output range, OUT	VDD=+5V, Unloaded	0.05		4.95	V
Output range, OUT	VDD=+5V, ±1mA load	0.40		4.60	V
Output Impedance, OUT				1	Ω
Output Impedance, OUTR			12	20	Ω
Capacitive load, OUT				5	nF
Capacitive load, OUTR	(Note 1)			5	nF
Input voltage range, INN, INP	VDD=+5V (Note 2)	0.3		3.5	V

Note 1: OUTR is also stable with capacitive loading larger than 10μF.

Note 2: Input voltage range with a differential input is also limited by the available swing on DOP/DON. See application information.

Parameter Regulators	Conditions	Min	Typ	Max	Unit
Supply voltage, PVDD		18		36	V
Supply current, PVDD			1.5	1.9	mA
Supply voltage, POUT	Supply on POUT, PVDD=0V	10		18	V
Supply current, POUT	PVDD=0V, POUT=12V		1.2	1.9	mA
Output current, POUT	Continuously (Note 3)			20	mA
VREF	@+25°C	4.85	5.00	5.15	V
VREF drift	+25°C to +225°C			±50	ppm/°C
VREF drift	-55°C to +25°			±75	ppm/°C
Output impedance, VREF				1	Ω
Output current, VREF	Continuously (Note 3)			20	mA
TEMP	@+25°C, I(TEMP)=1mA		3.5		V
TEMP drift	I(TEMP)=1mA		-5		mV/°C

Note 3: Maximum continuous current might be reduced to keep Tj < +225°C.



SG0611

◆ TYPICAL OPERATING CHARACTERISTICS

At $T_a = +25^\circ\text{C}$, $PVDD = 24\text{V}$, unless otherwise noted.

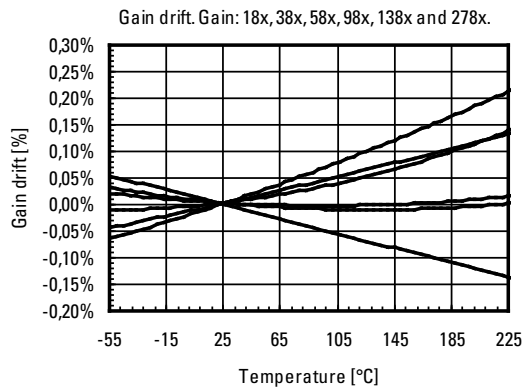
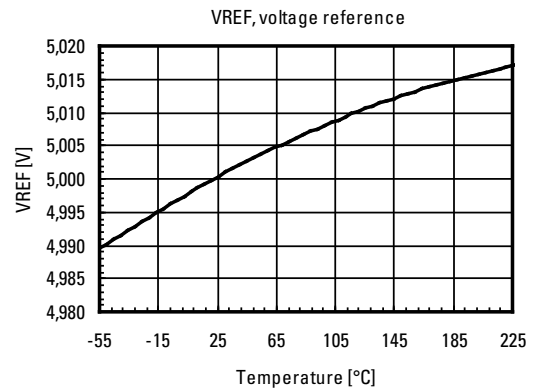
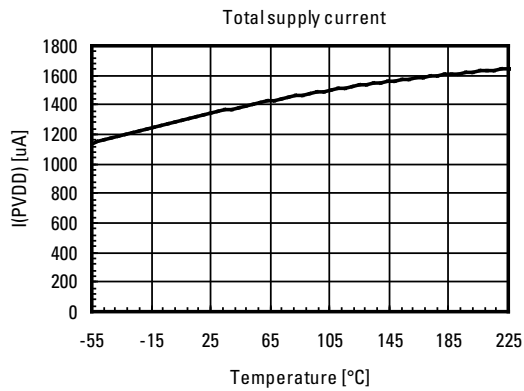



SG0611

◆ PIN DESCRIPTION

Name	Description
PVDD	Pre-regulator input. Recommended pin for supply voltage.
POUT	Pre-regulator output. Can be used as input of supply when pre-regulator is not used.
VREF	Reference voltage output (+5V). Used for sensor and VDD supply.
VDD	Supply voltage for the amplifiers (+5V). Should be connected to VREF.
GND	Signal ground.
PGND	Ground for the regulators. Should be connected to GND.
TEMP	Internal temperature sensing diode anode.
INP	Positive signal input.
INN	Negative signal input.
FBP	Feedback for the positive signal.
FBN	Feedback for the negative signal.
DOP	Differential amplifier positive output.
DON	Differential amplifier negative output.
GA	Gain selection pin, optional shorted to FBP, GC or GD.
GB	Gain selection pin, optional shorted to FBP, GC or GD.
GC	Gain selection pin, optional shorted to FBN, GA or GB.
GD	Gain selection pin, optional shorted to FBN, GA or GB.
OADJ	Output offset adjustment. Normally connected to AGND.
OUTR	Output with internal resistor for better capacitive load capability.
OUT	Output.
N.C	Should not be connected.

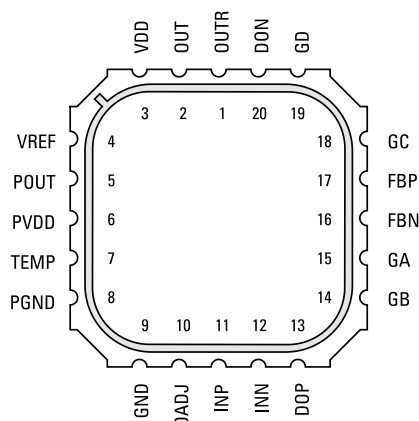

20L CQFN Pinout

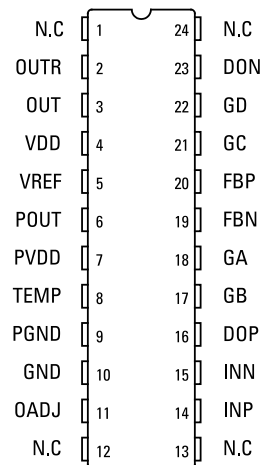

24L CERDIP Pinout



SG0611

◆ FUNCTIONAL OVERVIEW

SG0611 is designed with 3 main function blocks; pre-regulator, voltage reference and amplifiers.

Pre-regulator

This regulator is designed to handle large input voltage variations. In noisy environments, a decoupling capacitor may be needed between POUT and GND.

Voltage reference

The 5V reference is designed to supply both the sensor bridge and the amplifiers.

Amplifiers

The differential input amplifier has a programmable gain that can be selected to more than 40 different values using external jumpers. The differential outputs, DOUTN and DOUTP, are available to permit low-pass filtering using external capacitors.

The single-ended output amplifier, with a fixed gain of 2x, has two outputs, OUT and OUTR, that can be used depending on the capacitive load and the output impedance requirements.

◆ APPLICATION INFORMATION

Supply considerations

Due to the design of the ESD-protection cells, SG0611 must be supplied using a R-C-R filter combination. Recommended values are 10Ω and 100nF.

The circuit is normally supplied on PVDD through the pre-regulator with a 18-36V supply. It is possible to apply a lower supply voltage (10-18V) on POUT. The noise rejection from the supply will be reduced if the pre-regulator is not used. PVDD can in this case be left open or shorted to GND. A +5V supply can be applied on VDD directly if leaving VREF unconnected.

External filter capacitors might be needed on POUT to GND and on VREF to GND in noisy environments. The two ground pins, GND and PGND, should always be connected together.

Output offset adjustment

SG0611 has got an output offset adjustment pin, OADJ. A window comparator detects the connection on OADJ and switches internal offsets accordingly.

There are three ways to connect the OADJ pin: to GND, to VDD or to a resistor divider from VDD to GND. The resistor divider will make it possible to adjust the output voltage as a result from an offset in the sensor.

A: OADJ to GND: Used for sensors with a positive signal only and no need for sensor adjustment.

B: OADJ=0.6...4.4V: Used for sensors with a positive signal only and with need for offset adjustment.

The output can be adjusted $\pm 0.95V$. Output offset is $OADJ * 0.5 - 1.25V$.

C: OADJ to VDD: Used for sensors with both positive and negative signal. With no input signal, the output voltage will be 2.5V. This will allow for a $\pm 2.45V$ output signal.

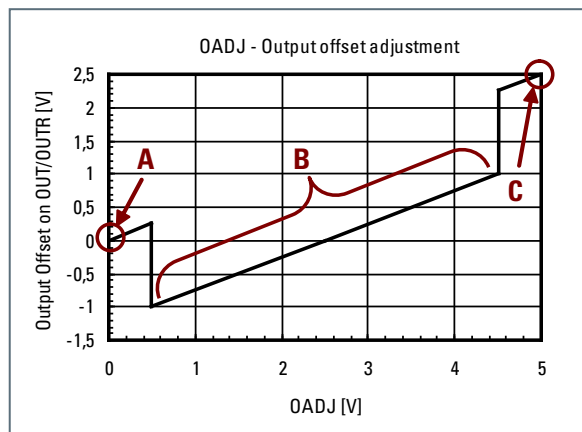

Note that high value external resistors on OADJ will reduce CMRR and increase the gain temperature drift. An external resistance of 3k will decrease the CMRR from 80dB to 40dB.

Transient precautions

SG0611 is sensitive to transients when powered. This is especially important on VDD and VREF. The wires to these pins should be kept short and not touched or probed. This is normally not a problem in an application but care should be taken during test and evaluation.



SG0611

◆ APPLICATION INFORMATION

Gain settings

The amplifier gain can be programmed using external links between the pins GA, GB, GC, GD, FBN and FBP.

Other gain settings are possible by inserting external resistors in the positions of the links. This is not recommended due to the high temperature coefficient of the resistors inside the SG0611. The mismatch between the two resistor types will introduce a temperature drift of the gain.

The following table shows the usable gain combinations using only external links with their nominal gain value:

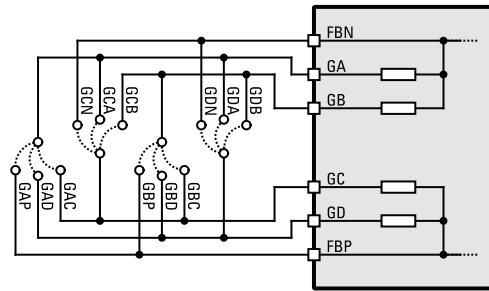

Connection of gain setting links

Gain	Links	Gain	Links	Gain	Links
18.0	None	78.0	GBP+GDN	151.3	GAP+GBD
31.3	GBD	79.3	GAC+GBD	155.1	GAD+GBP+GCN
35.1	GAD	79.5	GAC+GBD+GCB	158.0	GAP+GDN
35.8	GAD+GBD	86.0	GAC+GDN	164.7	GAP+GBC
38.0	GDN	91.3	GAC+GBC+GDN	166.6	GAP+GBC+GDB
44.7	GBC	98.0	GCN	178.0	GAP+GBP
46.6	GBC+GDB	106.0	GAC+GBP	184.7	GAP+GBC+GDN
58.0	GBP	111.3	GBD+GCN	198.0	GAP+GBP+GDN
61.8	GAD+GBC	112.5	GAC+GBP+GDA	218.0	GAP+GCN
64.7	GBC+GDN	115.1	GAD+GCN	231.3	GAP+GBD+GCN
66.0	GAC	115.8	GAD+GBD+GCN	238.0	GAP+GCN+GDN
71.3	GAC+GBC	118.0	GCN+GDN	258.0	GAP+GBP+GCN
72.5	GAC+GDA	126.0	GAC+GBP+GDN	278.0	GAP+GBP+GCN+GDN
75.1	GAD+GBP	138.0	GAP		

Common mode range limitations

The input common-mode range is limited by the input voltage range of the INN and INP input on the amplifiers. When larger input signals are applied, the input common-mode range could be further limited by the supply limitations on the DOP and DON outputs. This must be observed carefully as a saturating DOP or DON can be difficult to observe on the OUT/OUTR outputs. It can be seen as a gain reduction only. The gain of 2x in the second amplifier stage helps to increase the useful input common-mode range.

Bandwidth limitation

The signal bandwidth can be reduced further to reduce noise from the sensor by adding capacitors over the amplifier. Place capacitors with same values on DOP to FBP and DON to FBN.



SG0611

◆ TYPICAL APPLICATION DIAGRAM

Minimum configuration

The following diagram is an example of a minimum configuration. The gain is set to 98x. The supply filter is preferably mounted on the normal temperature side. No

external components on the high temperature side is necessary. No output offset adjustment has been done using OADJ. The output can only show positive values from the sensor.

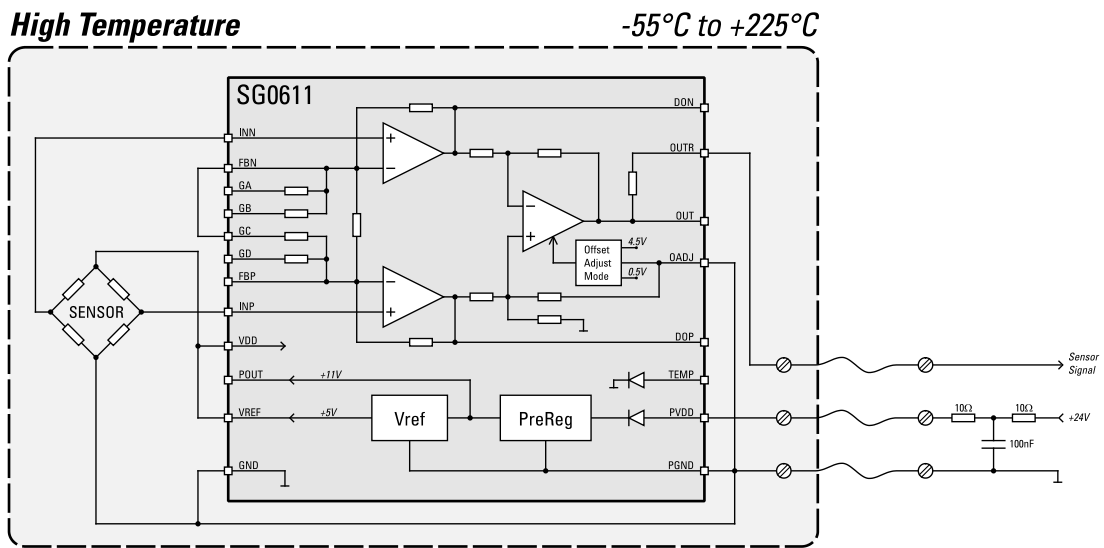

Minimum configuration. Gain set to 98x.

Application example

This diagram shows more internal details of the SG0611 with the gain setting connections. The output offset is

adjusted using a trim potentiometer or resistor divider. A pull-up resistor supplies a near-constant current for temperature measurements.

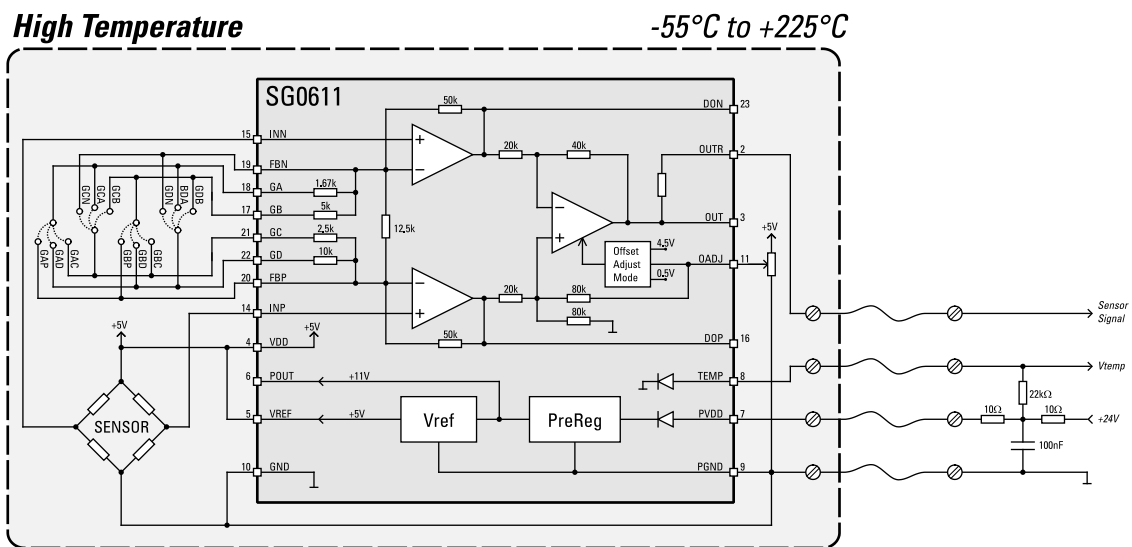

Application example. The pin numbers shown refers to the 24L-CERDIP package. Internal resistor values are approximations and shown for information only.



SG0611

◆ SG0611 VARIANTS

SG0611 is available in different packages and in die form. SG0611 is also available in different temperature and screening classes as described below. Other package and test options are possible. Please consult SGA for special requests.

Package options

Part Number	Package	Description
SG0611/X	Die form	Die size 2.30 * 2.18mm Normally delivered on chip tray with 100 die per tray
SG0611/V	20L CQFN	6x6mm Ceramic QFN Normally delivered on tray with 25 parts per tray
SG0611/G	24L CERDIP	Narrow version, 0.3" wide Normally delivered in sticks with 15 parts per stick

Test options - Die part

SG0611/X (Die form) is 100% tested on wafer level in room temperature with an additional sample test over whole temperature range on assembled parts from the same production batch. The standard test option is:

Suffix	Description
/N1	Sample test has been done on packaged parts at -55°C, +25°C and +225°C to AQL level 0.1%

Test options - Packaged parts

All parts in all test options have gone through a limited screening program including:

- Internal visual inspection according to MIL-STD-883 method 2010.
- Temperature cycling according to MIL-STD-883 method 1010.
- Constant acceleration according to MIL-STD-883 method 2001.
- Seal fine/gross according to MIL-STD-883 method 1014.
- Electrical test in +25°C

The standard test options are:

Suffix	Description
/N1	100% test in +25°C, Sample test at -55°C, +25°C, and +225°C to AQL level 0.1%
/N4	100% test in -55°C, +25°C, and +225°C
/N8	100% test in -55°C, +25°C, and +225°C and screened including 160h burn-in at +125°C

Other test options are possible. Please consult SGA for special requests.

◆ SG0611 CUSTOMISATION

SG0611 can be tested or screened to customer requirements. SG0611 can also be customised for specific needs by changing one or more masks or even by adding additional analog or digital blocks. Please consult SGA for details



SG0611

◆ DIE INFORMATION

A conducting adhesive must be used to attach the die.
The substrate must be electrically connected to GND.

Die size	2.30 x 2.18mm
Die thickness	0.4 - 0.5mm
Passivation opening	90 x 90µm
Smallest pad pitch	187µm
Bonding Surface	Aluminium
Backside finish	Silicon

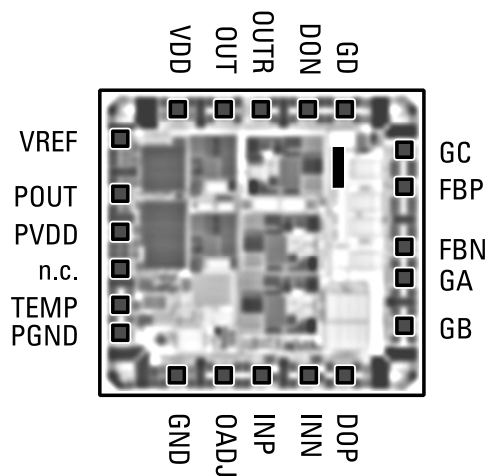

Die layout. Die orientation is defined by black rectangle which indicates text "SG0611".

Pin/Pad	X [µm]	Y [µm]
OUTR	917	1740
OUT	677	1740
VDD	371	1740
VREF	0	1550
POUT	0	1185
PVDD	0	938
n.c.	0	698
TEMP	0	452
PGND	0	265
GND	371	0
OADJ	677	0
INP	917	0
INN	1222	0
DOP	1462	0
GB	1860	324
GA	1860	630
FBN	1860	831
FBP	1860	1234
GC	1860	1474
GD	1462	1740
DON	1222	1740



SG0611

PACKAGE INFORMATION

20L CQFN Package

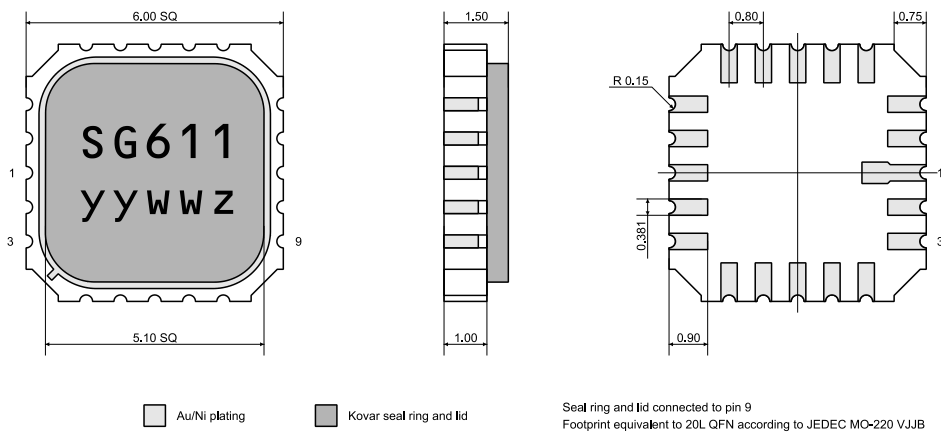

20L CQFN package drawing

24L CERDIP Package

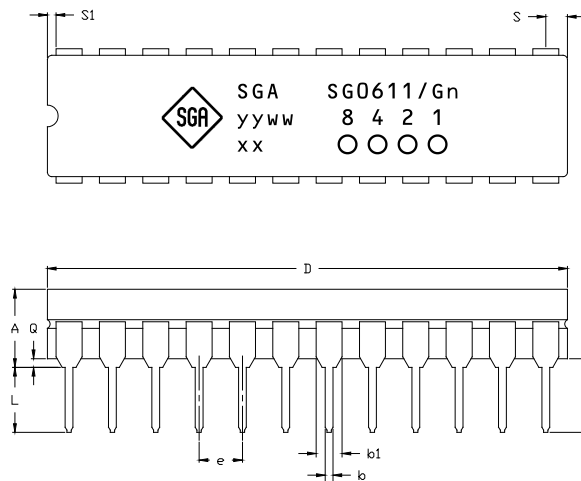

Note: Test option marked as a coloured circle below the corresponding number.

	Min [Inches]	Max [Inches]	Min [mm]	Max [mm]
A	-	0.200	-	5.08
b	0.014	0.023	0.36	0.58
b1	0.045	0.065	1.14	1.65
c	0.008	0.015	0.20	0.38
D	-	1.280	-	32.51
E	0.220	0.310	5.59	7.87
E1	0.290	0.320	7.37	8.13

	Min [Inches]	Max [Inches]	Min [mm]	Max [mm]
e	-	0.100 BSC	-	2.54 BSC
L	0.125	0.200	3.18	5.08
L1	0.150	-	3.81	-
Q	0.015	0.060	0.38	1.52
S	-	0.098	-	2.49
S1	0.005	-	0.13	-
α	0°	15°	0°	15°

24L CERDIP package drawing



◆ SALES CONTACT

***Please visit our website www.sga.se
for more information about our
representatives and distributors,
or contact SGA directly.***

specific 
components

Svenska Grindmatriser AB
Brigadgatan 16
SE-587 58 Linköping
Sweden

Phone: +46 13 36 46 60
Fax: +46 13 36 46 61
E-mail: info@sga.se
www.sga.se

◆ ADDITIONAL INFORMATION

Support

If you need any technical advice or help in any way regarding this product, please send an E-mail to support@sga.se, or call SGA, +46 13 364660, and ask for support. We will always be pleased to discuss your requirements and how this product could be used in your application.

Electrostatic discharge (ESD) precautions

Electrostatic Discharge (ESD) can damage this integrated circuit. SGA recommends that all integrated circuits are handled with appropriate precautions. Failure to observe proper handling may cause performance degradation or complete failure.

Data sheet identification

Advance Information

The product is in a formative or design stage. The data sheet contains target specifications for product development. Engineering samples may or may not be available.

Preliminary Specification

The data sheet contains preliminary data. Additional data may be added later. Engineering samples are available. Production quantities may or may not be available.

Product Specification

The data sheet contains final product specifications. The product is in full production.

Notice

Svenska Grindmatriser AB (SGA) believes the information contained in this data sheet to be correct and accurate at the time of printing. However, SGA assumes no liability for the use of this information. Use shall be entirely at the user's own risk.

Svenska Grindmatriser AB (SGA) reserves the right to make changes without further notice to the product to improve reliability, function or design. SGA does not assume any liability arising out of the application or use of any product or circuits described herein.

© 2012 Svenska Grindmatriser AB.
All rights reserved