

Power MOSFET

P10F50HP2

500V 10A

特長

- 高耐圧
- 低オン抵抗
- 高速スイッチング
- 高アバランシェ耐量、高 di/dt 耐量

Feature

- High Voltage
- Low R_{ON}
- Fast Switching
- High Avalanche durability, High di/dt durability

■ 外観図 OUTLINE

Package : FTO-220AG (3pin)

Unit : mm

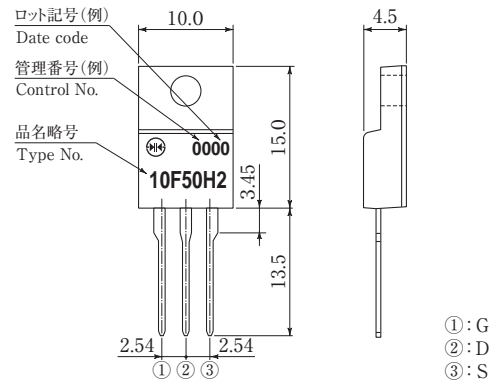

外形図については新電元 Web サイトをご参照下さい。捺印表示については捺印仕様をご確認下さい。

For details of the outline dimensions, refer to our web site. As for the marking, refer to the specification "Marking, Terminal Connection".

■ 定格表 RATINGS

● 絶対最大定格 Absolute Maximum Ratings (指定のない場合 T_c = 25°C / unless otherwise specified)

項目 Item	記号 Symbol	条件 Conditions	規格値 Ratings	単位 Unit
保存温度 Storage Temperature	T _{stg}		-55~150	°C
チャネル温度 Channel Temperature	T _{ch}		150	
ドレイン・ソース間電圧 Drain-Source Voltage	V _{DSS}		500	V
ゲート・ソース間電圧 Gate Source Voltage	V _{GSS}		±30	
ドレイン電流 (直流) Continuous Drain Current (DC)	I _D		10	A
ドレイン電流 (ピーク) Continuous Drain Current (Peak)	I _{DP}	パルス幅 10 μs, duty = 1/100 Pulse width 10 μs, duty = 1/100	40	
ソース電流 (直流) Continuous Source Current (DC)	I _S		10	W
全損失 Total Power Dissipation	P _T		79	
繰り返しアバランシェ電流 Repetitive Avalanche Current	I _{AR}	Starting T _{ch} = 25°C, T _{ch} ≤ 150°C	10	A
単発アバランシェエネルギー Single Avalanche Energy	E _{AS}	Starting T _{ch} = 25°C, T _{ch} ≤ 150°C	60	mJ
繰り返しアバランシェエネルギー Repetitive Avalanche Energy	E _{AR}	Starting T _{ch} = 25°C, T _{ch} ≤ 150°C	6	mJ
ドレイン・ソースダイオード耐量 Drain-Source Diode di/dt	di/dt	I _S = 10A, T _c = 25°C	350	A/μs
絶縁耐圧 Dielectric Strength	V _{dis}	一括端子・ケース間, AC 1 分間印加 Terminals to case, AC 1 minute	2	kV
締め付けトルク Mounting Torque	TOR	(推奨値: 0.3N·m) (Recommended torque: 0.3N·m)	0.5	N·m

● 電氣的・熱的特性 Electrical Characteristics (指定のない場合 T_c = 25°C / unless otherwise specified)

項目 Item	記号 Symbol	条件 Conditions	規格値 Ratings			単位 Unit
			MIN	TYP	MAX	
ドレイン・ソース間降伏電圧 Drain-Source Breakdown Voltage	V _{(BR)DSS}	I _D = 1mA, V _{GS} = 0V	500	—	—	V
ドレイン遮断電流 Zero Gate Voltage Drain Current	I _{DSS}	V _{DS} = 500V, V _{GS} = 0V	—	—	100	μA
ゲート漏れ電流 Gate-Source Leakage Current	I _{GSS}	V _{GS} = ±25V, V _{DS} = 0V	—	—	±10	μA
順伝達コンダクタンス Forward Transconductance	g _{fs}	I _D = 5A, V _{DS} = 10V	5	10.5	—	S
ドレイン・ソース間オン抵抗 Static Drain-Source On-state Resistance	R _{(DS)ON}	I _D = 5A, V _{GS} = 10V	—	0.6	0.75	Ω
ゲートしきい値電圧 Gate Threshold Voltage	V _{TH}	I _D = 1mA, V _{DS} = 10V	3.0	3.75	4.5	V
ソース・ドレイン間ダイオード順電圧 Source-Drain Diode Forward Voltage	V _{SD}	I _S = 5A, V _{GS} = 0V	—	—	1.5	V
熱抵抗 Thermal Resistance	θ _{jc}	接合部・ケース間 Junction to case	—	—	1.58	°C/W
ゲート全電荷量 Total Gate Charge	Q _g	V _{DD} = 400V, V _{GS} = 10V, I _D = 10A	—	20	—	nC
入力容量 Input Capacitance	C _{iss}	V _{DS} = 50V, V _{GS} = 0V, f = 1MHz	—	820	—	pF
帰還容量 Reverse Transfer Capacitance	C _{rss}		—	6	—	
出力容量 Output Capacitance	C _{oss}		—	85	—	
ターンオン遅延時間 Turn-on delay time	t _{d(on)}	I _D = 5A, R _L = 30Ω, V _{DD} = 150V, R _g = 50Ω, V _{GS(+)} = 10V, V _{GS(-)} = 0V	—	20	—	ns
上昇時間 Rise time	t _r		—	32	—	
ターンオフ遅延時間 Turn-off delay time	t _{d(off)}		—	68	—	
降下時間 Fall time	t _f		—	30	—	

■特性図 CHARACTERISTIC DIAGRAMS

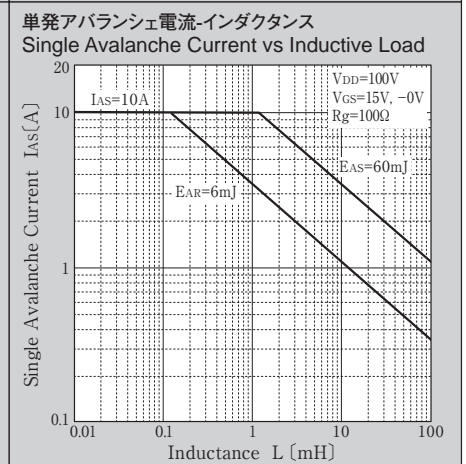
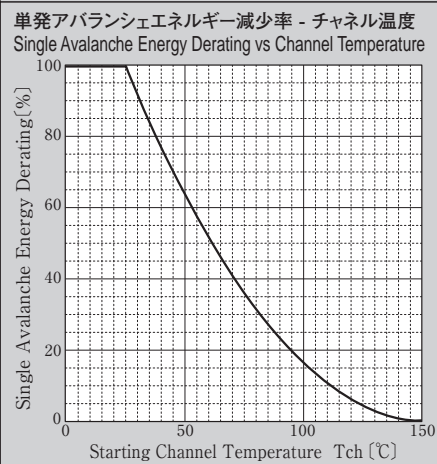
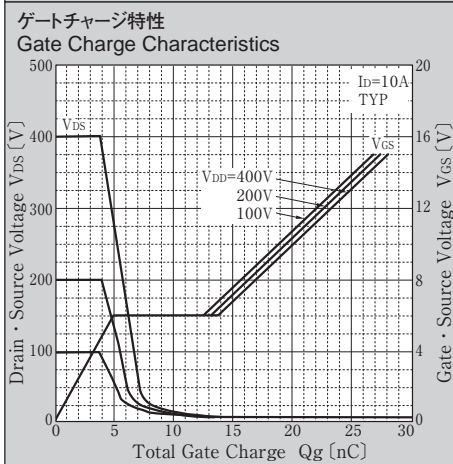
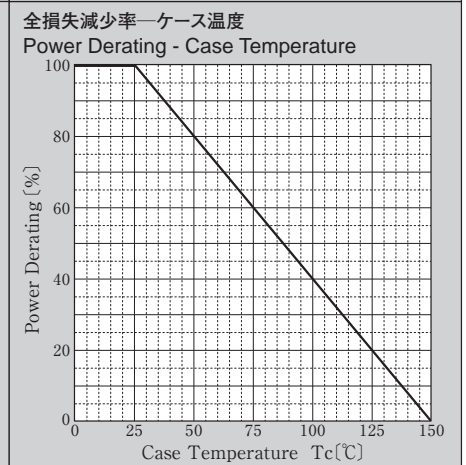
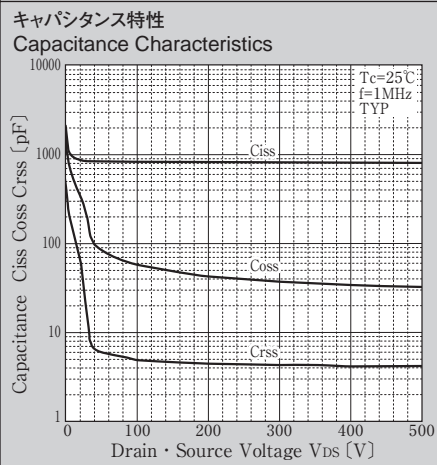
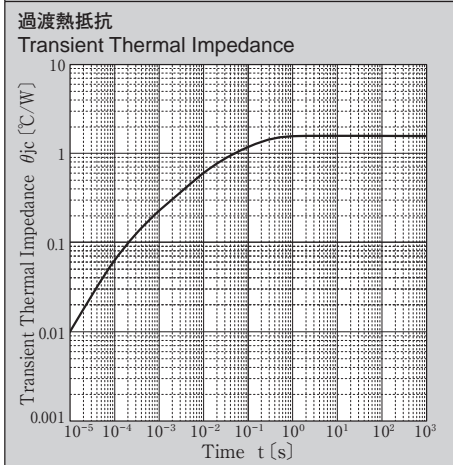
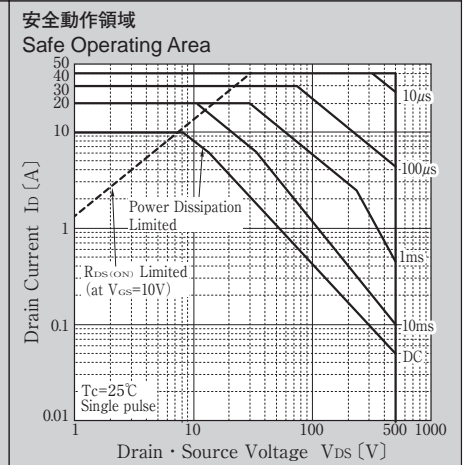
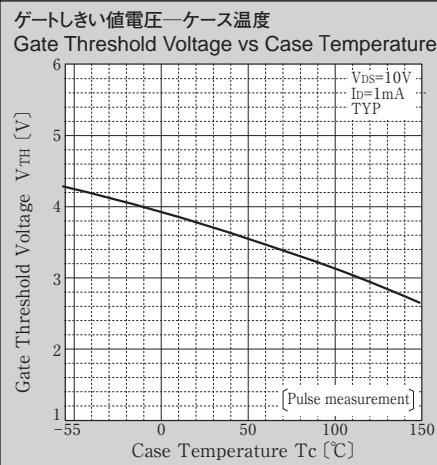
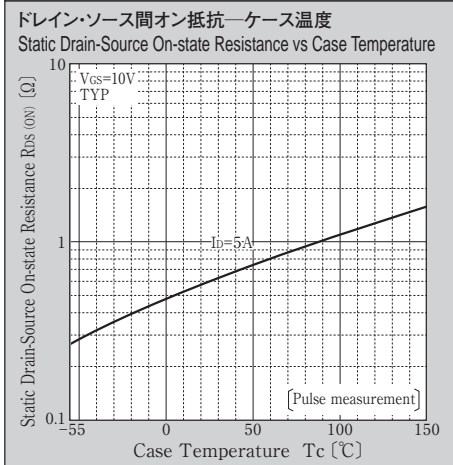
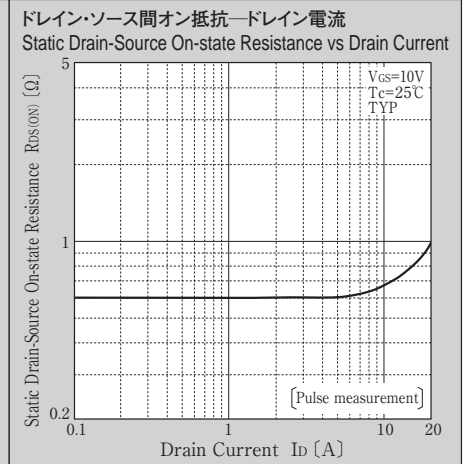
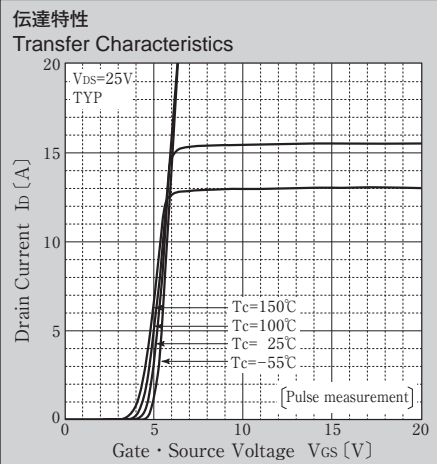
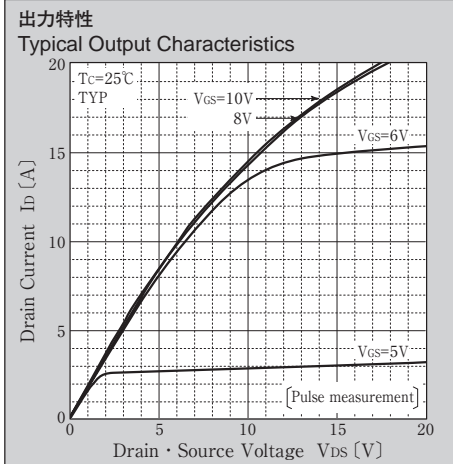

* Sine wave は 50Hz で測定しています。
* 50Hz sine wave is used for measurements.