

D1FJ4**40V 2A****特長**

- 小型SMD
- 低 $I_R=0.2\text{mA}$
- 熱暴走を起こしにくい

Feature

- Small SMD
- Low $I_R=0.2\text{mA}$
- Resistance for thermal run-away

用途

- スイッチング電源
- DC/DC コンバータ
- 家電、ゲーム、OA 機器
- 通信、ポータブル機器

Main Use

- Switching Regulator
- DC/DC Converter
- Home Appliance, Game, Office Automation
- Communication, Portable set

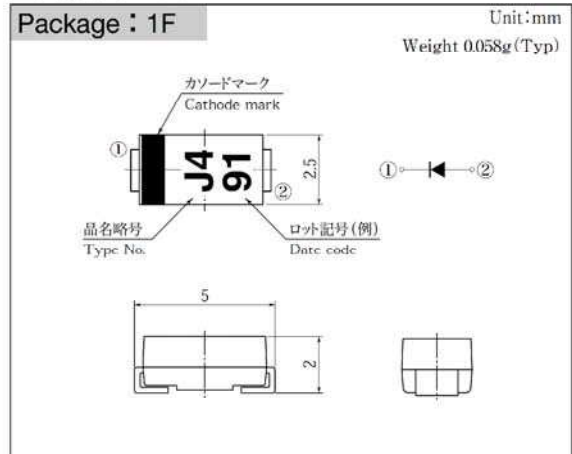
■外観図 OUTLINE

外形図については新電元Webサイト又は〈半導体製品一覧表〉をご参照下さい。捺印表示については捺印仕様をご確認下さい。

For details of the outline dimensions, refer to our web site or Semiconductor Short Form Catalog. As for the marking, refer to the specification "Marking, Terminal Connection".

■定格表 RATINGS**●絶対最大定格 Absolute Maximum Ratings (指定のない場合 $T_I = 25^\circ\text{C}$)**

| 項目 Item | 記号 Symbol | 条件 Conditions | 品名 Type No. | D1FJ4 | 単位 Unit |
|---|------------------|---|---|---------|------------------|
| 保存温度 Storage Temperature | T_{stg} | | | -55~150 | $^\circ\text{C}$ |
| 接合部温度 Operation Junction Temperature | T_j | | | 150 | $^\circ\text{C}$ |
| せん頭逆電圧 Maximum Reverse Voltage | V_{RM} | | | 40 | V |
| 出力電流 Average Rectified Forward Current | I_o | 50Hz正弦波、抵抗負荷 50Hz sine wave, Resistance load | $T_a = 62^\circ\text{C}$ プリント基板実装 On glass-epoxy substrate | 1.0 | A |
| | | | $T_a = 48^\circ\text{C}$ アルミナ基板実装 On alumina substrate | 1.5 | |
| | | | $T_I = 117^\circ\text{C}$ | 2.0 | |
| せん頭サージ順電流 Peak Surge Forward Current | I_{FSM} | 50Hz正弦波、非繰り返し1サイクルせん頭値、 $T_j = 25^\circ\text{C}$ 50Hz sine wave, Non-repetitive 1 cycle peak value, $T_j = 25^\circ\text{C}$ | | 50 | A |

●電氣的・熱的特性 Electrical Characteristics (指定のない場合 $T_I = 25^\circ\text{C}$)

| | | | | |
|------------------------------|------------------|--|--------------------------------------|--------------------|
| 順電圧 Forward Voltage | V_F | $I_F = 1.5\text{A}$, パルス測定 Pulse measurement | MAX 0.57 | V |
| | | $I_F = 2.0\text{A}$, パルス測定 Pulse measurement | MAX 0.61 | |
| 逆電流 Reverse Current | I_R | $V_R = V_{\text{RM}}$, パルス測定 Pulse measurement | MAX 0.2 | mA |
| 接合容量 Junction Capacitance | C_j | $f = 1\text{MHz}$, $V_R = 10\text{V}$ | TYP 96 | pF |
| 熱抵抗 Thermal Resistance | $\theta_{j\ell}$ | 接合部・リード間 Junction to lead | MAX 23 | $^\circ\text{C/W}$ |
| | | 接合部・周囲間 Junction to ambient | アルミナ基板実装 On alumina substrate | |
| | | | プリント基板実装 On glass-epoxy substrate | MAX 157 |

■特性図 CHARACTERISTIC DIAGRAMS

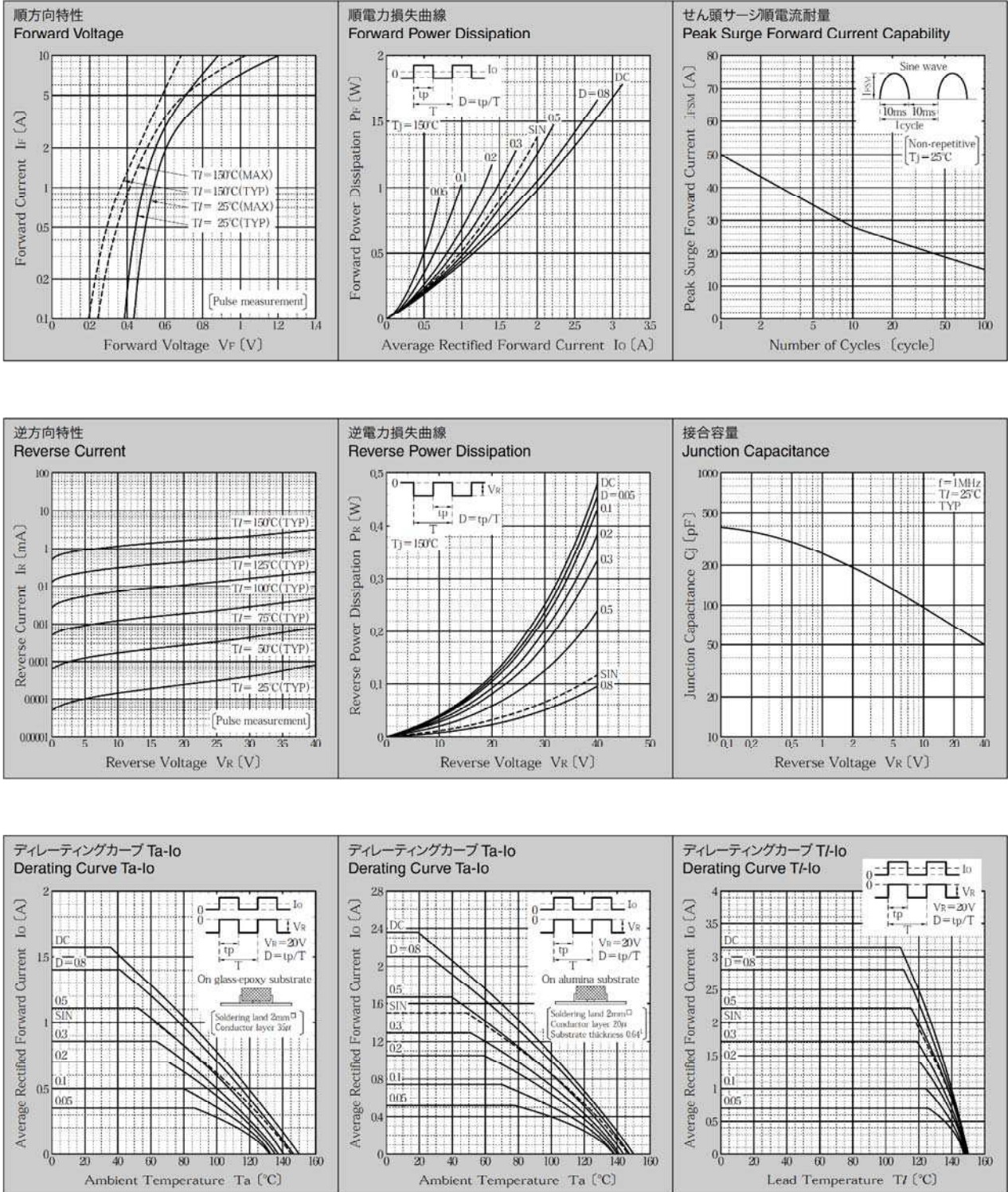

* Sine waveは50Hzで測定しています。
 * 50Hz sine wave is used for measurements.
 * 半導体製品の特性は一般的にバラツキを持っています。
 Typical is a statistical average of the device's ability.
 * Semiconductor products generally have characteristic variation.
 Typical is a statistical average of the device's ability.