

The SDD216 fast recovery diode is designed for use in voltage fed inverter circuits normally requiring the bypass function. Its relatively low recovery current and charge in combination with low thermal resistance offer a new advantage for optimizing other circuit components. It is manufactured by the proven multi-diffusion process with 77mm diameter silicon and is supplied in a disc-type package ready to mount using commercially available heat dissipators and clamping hardware.

#### FORWARD CONDUCTION CHARACTERISTIC

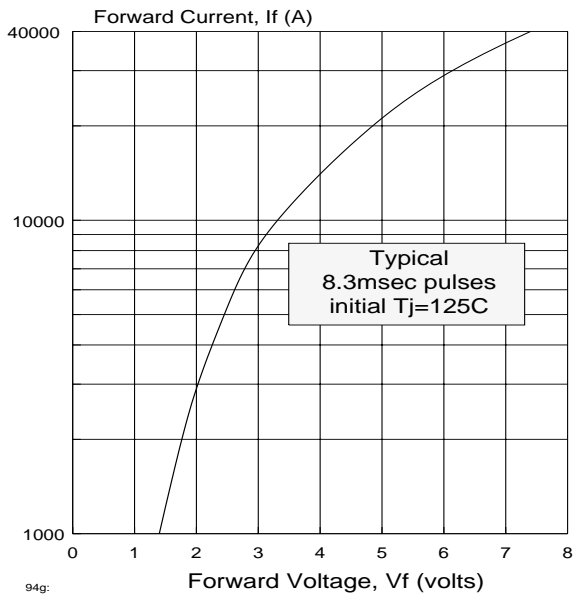

#### MAXIMUM RATINGS & PARAMETERS

Maximum repetitive peak reverse voltage	$V_{RRM}$	$T_j = 0$ to $+125^\circ\text{C}$	$t_D$ 2500	V
Maximum forward average & RMS current ratings	$I_{P(AV)}$ $I_{RMS}$	$T_{case} 70^\circ\text{C}$	1850 2900	A
Maximum reverse leakage current	$I_{RRM}$		200	ma
Forward voltage drop	$V_{FM}$	$I_T = 2000\text{A}$ $t_p = 8.3\text{ms}$ $T_j = 125^\circ\text{C}$	1.75	V
Maximum peak recovery current*	$I_{RR}$	@ 10 A/us @ 100 A/us	40 300	A
Maximum recovery charge	$Q_{RR}$	@ 10 A/us @100A/us	128 720	$\mu\text{C}$

#### SELECTION TABLE

MODEL	$V_{RRM}$ $T_j = 0$ to $125^\circ\text{C}$
SDD216DK	2500 volts
SDD216TT	2000

#### THERMAL IMPEDANCE vs. ON-TIME

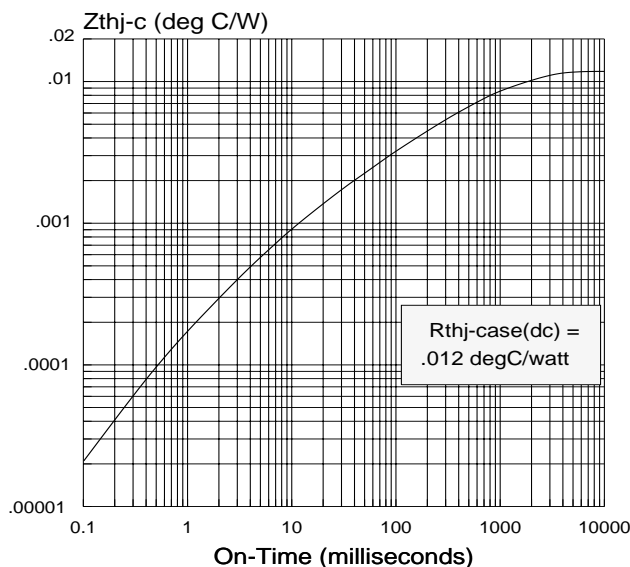

#### MECHANICAL OUTLINE

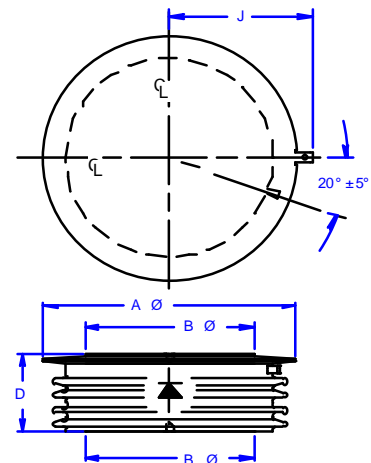

$A \Phi = 4.35$  in (110.5 mm)  
 $B \Phi = 2.88$  in (73.2 mm)  
 $D = 1.07$  in (27.2 mm)

CLAMPING FORCE REQUIRED  
 7000 - 9000 lb / 31.1 - 40.0 kN