

A641

40mm RECTIFIER DIODE

2600V / 1500A

The A641 rectifier diode features a nominal 40mm silicon junction diameter design, manufactured by the proven multi-diffusion process. High reverse voltage blocking capability is optimized with moderate recovery current and low forward voltage.

A641 is designed specifically for transportation, industrial and utility 50/60 Hz rectifiers having very high current surge and I²t requirements.

SELECTION TABLE

Model No.	Repetitive Peak Reverse Voltage $V_{RRM} @ T_J =$ 0 - 185°C	$V_{RRM} @ T_J$ = -40°C
A641LM	2600 V	2400 V
A641LE	2500	2300
A641LD	2400	2200
A641LC	2300	2100
A641LB	2200	2000
A641LA	2100	1900
A641L	2000	1800
A641PT	1900	1700
A641PN	1800	1600

FORWARD CHARACTERISTIC
Process Maximum @ T_J=160 C

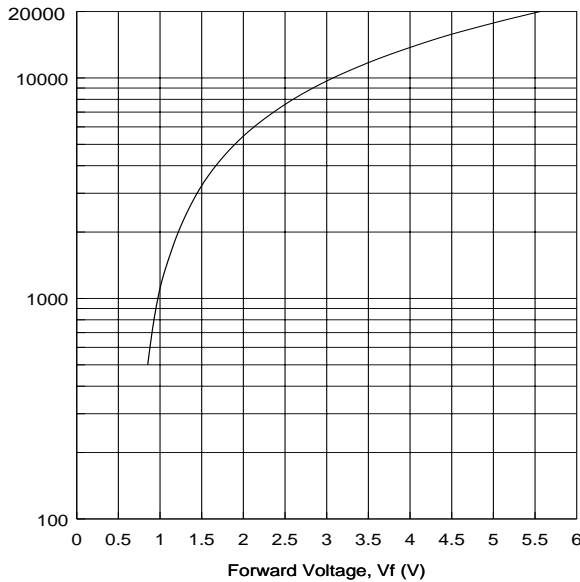

93c

THERMAL IMPEDANCE vs> POWER ON-TIME

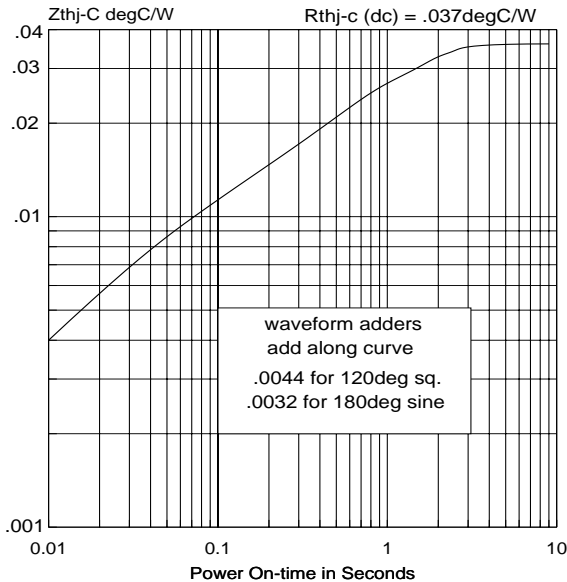

MECHANICAL OUTLINE

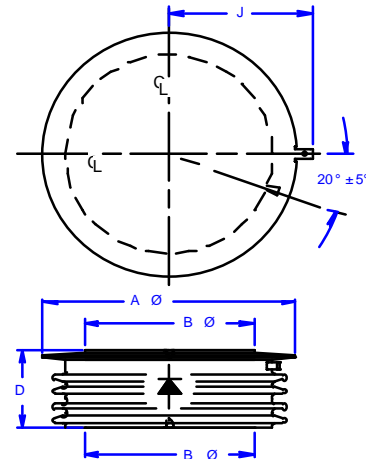

AØ = 2.30 in (58.0 mm)
BØ = 1.35 in (34.3 mm)
D = 1.04 in (26.4 mm)

CLAMPING FORCE REQUIRED
3500 -4200 lbs. 15.6 - 18.7kN

LIMITING CHARACTERISTICS AND RATINGS

PARAMETER UNITS	SYMBOL	TEST CONDITIONS	MAX. VALUES	
Average current	I_{AV}	half sine $T_C = 95^\circ\text{C}$	1500	A
Repetitive peak reverse voltage	V_{RRM}	$T_J = -40$ to $+185^\circ\text{C}$ 50/60 Hz	see page 1	V
Repetitive peak reverse current	I_{RRM}	$T_J = 185^\circ\text{C}$ 25°C	70 10	ma
Forward voltage	V_{FM}	$I_F = 1\text{kA}$, 25°C 160°C	1.095 0.99	V
Peak recovery current	I_{RM}	$T_J = 125^\circ\text{C}$ @ 10A/us	160	A
Non-rep peak surge current	I_{FSM}	$T_J = 160^\circ$ $t_p = 8.3\text{ms}$ $t_p = 10\text{ms}$ $V_R = 0$	17 15	kA

NON-REPETITIVE SURGE CURRENT AND I^2t CAPABILITY FOR FUSE COORDINATION

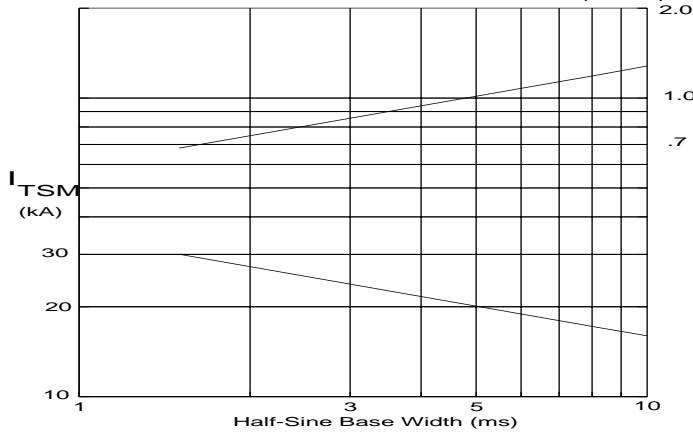

MAXIMUM PEAK RECOVERY CURRENT

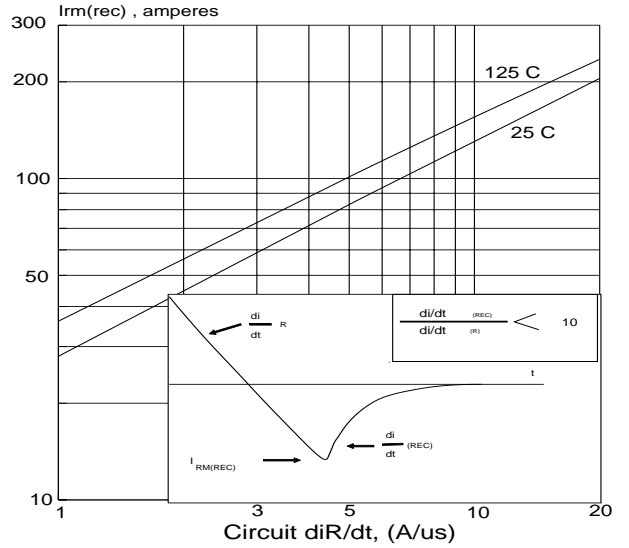

POWER DISSIPATION Full Cycle Average

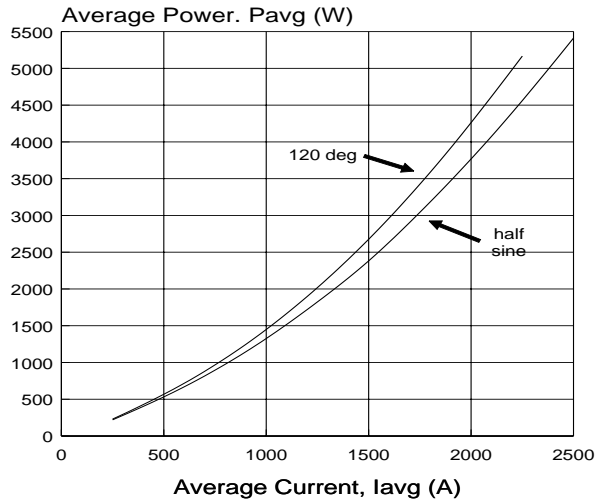

AVERAGE POWER DISSIPATION

$T_J = 160 \text{ degC}$

I_{AV} (A)	half sine	120° sq.
250	220	230
500	517	550
750	882	950
1000	1314	1435
1250	1817	2004
1500	2360	2661
1750	3035	3407
2000	3753	4242