

A800

77mm RECTIFIER DIODE

2600V / 4400A

The A800 rectifier diode features a nominal 77mm silicon junction diameter design, manufactured by the proven multi-diffusion process. High reverse voltage blocking capability is optimized with moderate recovery current and low forward voltage.

A800 is designed specifically for transportation, industrial and utility 50/60 Hz rectifiers having very high current surge and I²t requirements.

MAXIMUM FORWARD CHARACTERISTIC

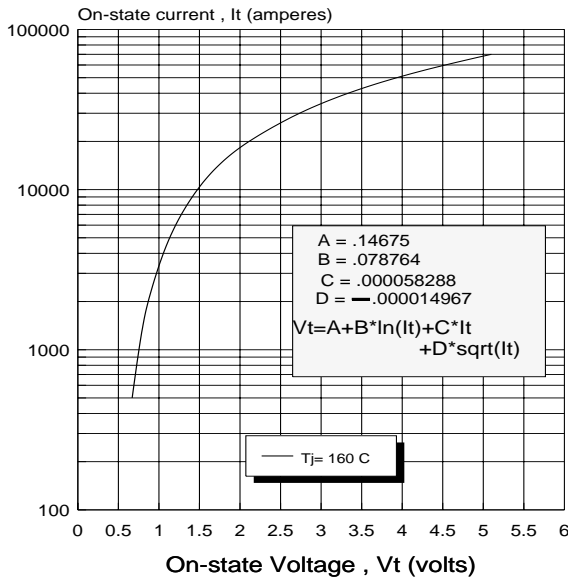

THERMAL IMPEDANCE vs. ON-TIME

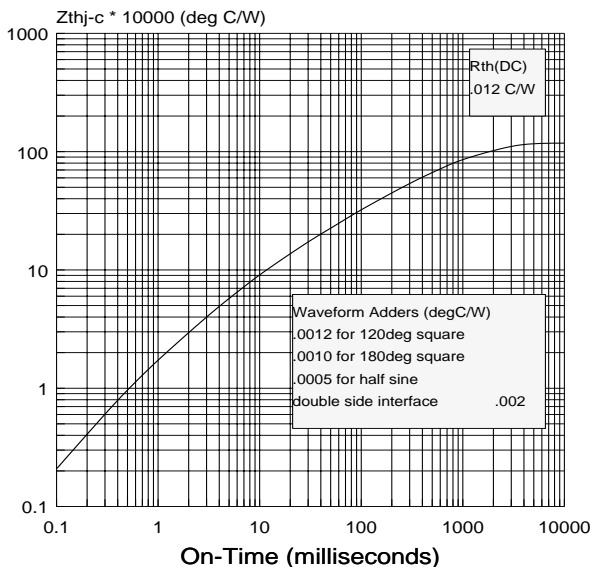

SELECTION TABLE

Model No.	Repetitive Peak Reverse Voltage	
	$V_{RRM} @ T_J = 0 - 185^\circ C$	$V_{RRM} @ T_J = -40^\circ C$
A800LM	2600V	2400V
A800LE	2500	2300
A800LD	2400	2200
A800LC	2300	2100
A800LB	2200	2000
A800LA	2100	1900
A800L	2000	1800
A800PT	1900	1700
A800PN	1800	1600

MECHANICAL OUTLINE

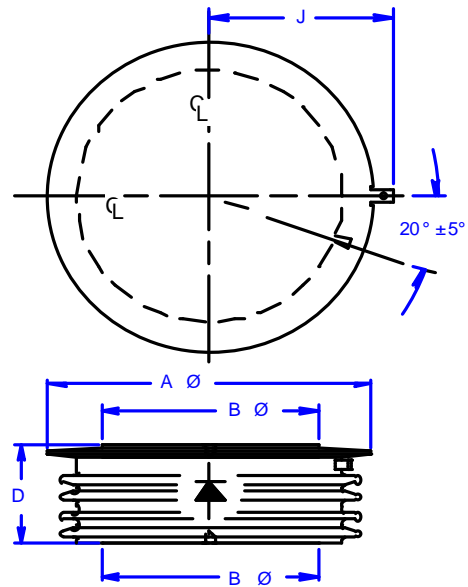

$A\phi = 4.35$ in (110.5 mm)
 $B\phi = 2.88$ in (73.2 mm)
 $D = 1.45$ in (36.8 mm)

CLAMPING FORCE REQUIRED
 7000 - 9000 lb / 31.1 - 40.0 kN

LIMITING CHARACTERISTICS AND RATINGS

<u>PARAMETER</u>	<u>SYMBOL</u>	<u>TEST CONDITIONS</u>	<u>MAX. VALUES</u>	<u>UNITS</u>
Average current	I_{AV}	half sine $T_c=100^\circ\text{C}$	4400	A
Repetitive peak reverse voltage	V_{RRM}	$T_J = -40$ to $+185^\circ\text{C}$ 50/60 Hz	see page 1	V
Repetitive peak reverse current	I_{RRM}	$T_J=185^\circ$ 25°	100 15	ma
Forward voltage	V_{FM}	$T_J=160^\circ$ $I_F=2000\text{A}$	0.865	V
Non-rep peak surge current	I_{FSM}	$T_J=160^\circ$ $t_p=8.3\text{ms}$ $t_p=10\text{ms}$ $V_R=0$	67 63	kA
Peak recovery current	I_{RM}	$di/dt=10\text{A}/\mu\text{s}$ $T_J=160^\circ$	290	A

POWER DISSIPATION
Full Cycle Average

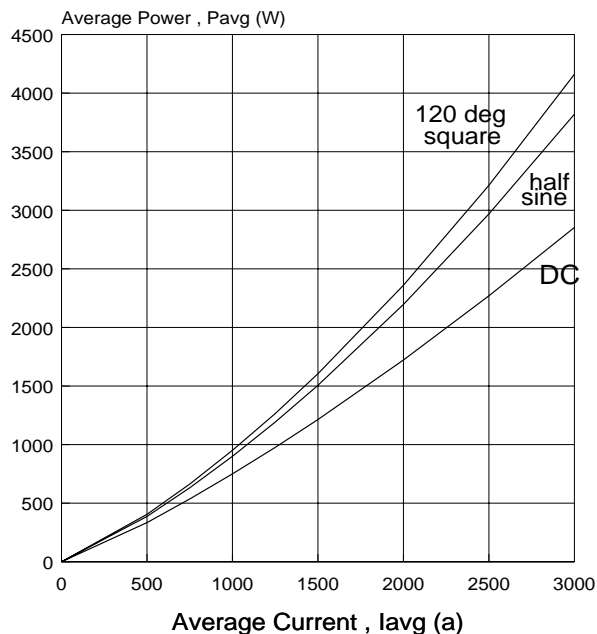

AVERAGE POWER DISSIPATION

$T_J = 160^\circ\text{C}$

I_{AV} (A)	(watts)		
	DC	half sine	120° sq. wave
500	334	387	405
750	533	631	663
1000	750	900	951
1250	976	1192	1265
1500	1214	1506	1605
1750	1463	1841	1970
2000	1722	2196	2360
2250	1991	2572	2774
2500	2270	2969	3213
2750	2558	3385	3658
3000	2853	3820	4161

MAXIMUM PEAK RECOVERY CURRENT

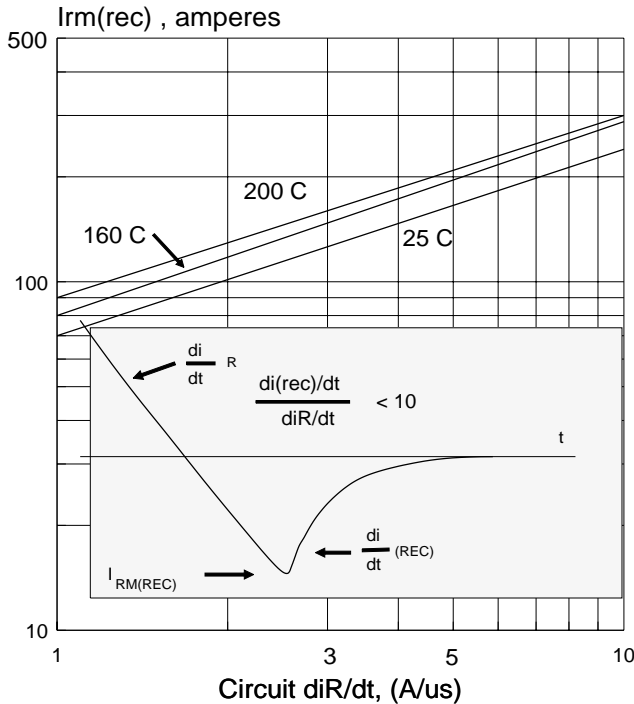

Non-repetitive Sub-Cycle Surge Rating

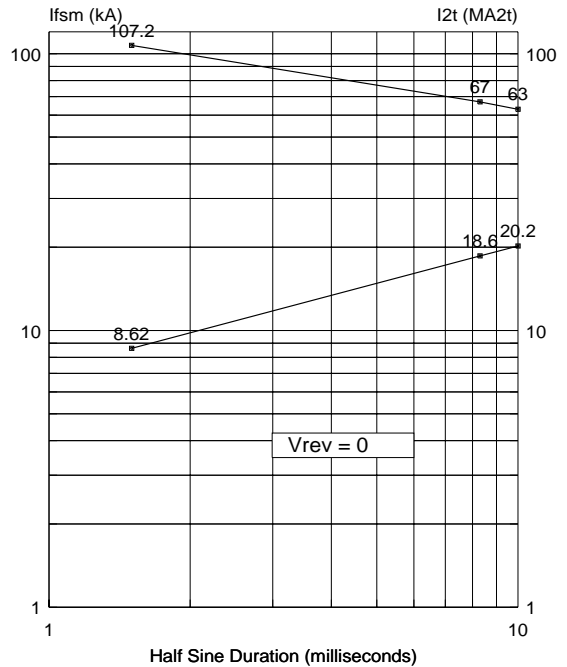

96h:

MOUNTING PRESSPAKS TO HEAT DISSIPATORS

The following instruction is essential for maintaining low, stable thermal and electrical resistances associated with the PRESSPAK to heat dissipator surfaces.

1. INSPECTION OF MATING SURFACES

Check each mating surface for nicks, scratches and surface finish. The PRESSPAK surface has a total indicator reading TIR < .0005 inch and surface finish 32 prior to factory electrical test in pressure fixtures. The dissipator surface should be equally as good. The TIR of a fully tested PRESSPAK may run higher but not exceed 0.001 inch (**) not including some minor nicks and scratches associated with the test fixtures. Any bow created by clamp system at assembly must keep flatness within 0.001 inch. (**) .002 inch for 77mm PRESSPAKS

2. SURFACE DEOXIDATION AND CLEANING

Although plated surfaces are recommended for aluminum and copper heat dissipators, bare surfaces may be used if careful attention to cleaning and treating is assured. Plated surfaces and PRESSPAKS should be lightly sanded with 600 grit paper, then oil or compound applied as recommended. Unplated aluminum surfaces should be vigorously abraded with a fine wire brush or 3M "Scotchbrite" coated with Alcoa EJC #2 compound. The EJC # 2 should be removed and the recommended compound applied.

3. FINAL SURFACE TREATMENT

Apply silicone oil or a very thin layer of grease or compound as indicated below. Rotate the PRESSPAK to properly distribute the applied agent.

- . bare copper - use G322L or LS2037
- . bare aluminum - use EJC #2 or G322L
- . tin plated copper or aluminum
 - preferably reapply DC550 or SF1154
 - alternatively use G623 or G322L
- . nickel plated aluminum - use DC550, G623 or G322L
- . silver plating - not recommended

Recommended silicone oils are SF1154 or DC550 (200 centistoke)

4. MOUNTING

Assemble with specified mounting force applied through a self-leveling swivel connection. The diameter of the swivel should be preferably equal but not smaller than the poleface diameter of the PRESSPAK. Center holes on the top and bottom of the PRESSPAK are for locating and positioning it to identical holes anticipated at the heat dissipator surfaces using 1/8" dia 3/16" roll pins.

NOTES:

Silicone oil DC550 (200 centistoke) is a product of DOW CORNING; clear silicone grease G623, yellow G322L and SF1154(200 centistoke) GE Silicones Waterford NY; EJC# 2 from ALCOA and black LS2037 from ARCO , 7301 Bessemer Ave. Cleveland OH.

Limit maximum joint temperature to:

- 95 C using EJC #2
- 150 C using SF1154, DC550 or G322L

5. APPLIED MOUNTING FORCE

The selection of an appropriate commercially available spring clamping hardware* should consider establishing and maintaining the specified mounting force over the operating temperature range and operating life of the PRESSPAK. Thus essential ratings such as thermal resistance, di/dt , surge current and thermal cycling will not be impaired.

Specified forces for this product are as

follows:

- 7000-9000 lbs.
- 31.1 -40.0 kN

* Consult factory for recommendations or more detailed instructions.