

# A801 77mm RECTIFIER DIODE

## 3200V / 3900A

The rectifier diode feature a nominal 77mm silicon junction diameter design, manufactured by the proven multi-diffusion process. High reverse voltage blocking capability is optimized with moderate recovery current and low forward voltage.

It is designed specifically for transportation, industrial and utility 50/60 Hz rectifiers having very high current surge and I<sup>2</sup>t requirements and are supplied as disc-type housings, ready to mount using commercially available heat dissipators and mechanical clamping hardware.

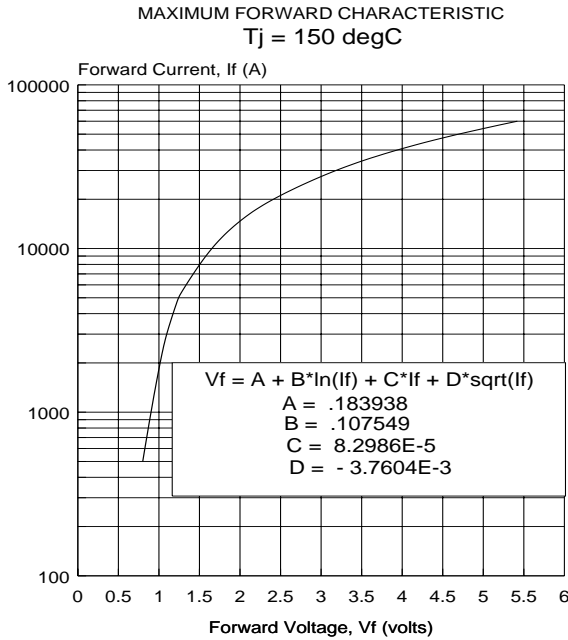

xyz-1:

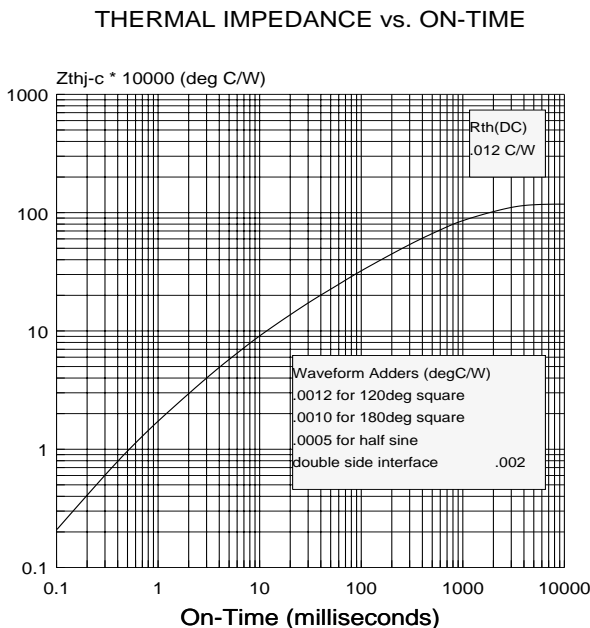

### SELECTION TABLE

**A801**

Model No.	Repetitive Peak Reverse Voltage		
	V <sub>RRM</sub> @ T <sub>J</sub> = 0 - T <sub>Jmax</sub>	T <sub>Jmax</sub>	V <sub>RRM</sub> @ T <sub>J</sub> = -40°C
A801CB	3200V	175°C	2900V
A801CA	3100		2800
A801CP	3000		2700
A801LT	2900		2650
A801LN	2800		2600
A801LS	2700		2500

### MECHANICAL OUTLINE

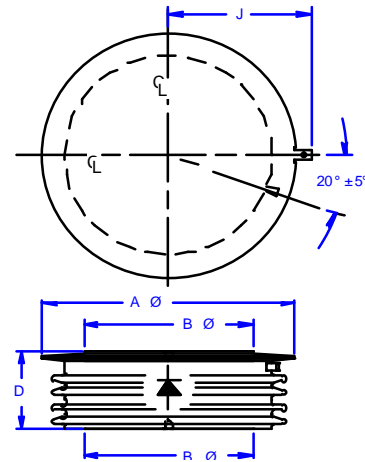

**AΦ = 4.35 in (110.5 mm)**  
**BΦ = 2.88 in (73.2 mm)**  
**D = 1.07 in (27.2 mm)**

**CLAMPING FORCE REQUIRED**  
 7000 - 9000 lb / 31.1 - 40.0 kN

LIMITING CHARACTERISTICS AND RATINGS

<u>PARAMETER</u>	<u>SYMBOL</u>	<u>TEST CONDITIONS</u>	<u>MAX. VALUES</u>	<u>UNITS</u>
Average current	$I_{AV}$	$T_j=175^\circ\text{C}$ $T_c=100^\circ\text{C}$ half sine wave	3900	A
Repetitive peak reverse voltage	$V_{RRM}$	$T_j = -40$ to $175^\circ\text{C}$ 50/60 Hz	see page 1	V
Repetitive peak reverse current	$I_{RRM}$	$T_j=175^\circ\text{C}$ $2^\circ$	100 15	ma
Forward voltage	$V_{FM}$	$T_j=150^\circ$ $I_F=2000\text{A}$	1.05	V
Non-rep peak surge current	$I_{FSM} / I^2t$	$T_j=175^\circ\text{C}$ $t_p=8.3\text{ms}$ $t_p=10\text{ms}$ $V_R=0$	60 / 14.9 57 / 16.2	kA / $\text{MA}^2\text{s}$
Peak recovery current	$I_{RM}$	$di/dt=10\text{A}/\mu\text{s}$ $T_j=175^\circ$	310	A

POWER DISSIPATION  
Full Cycle Average

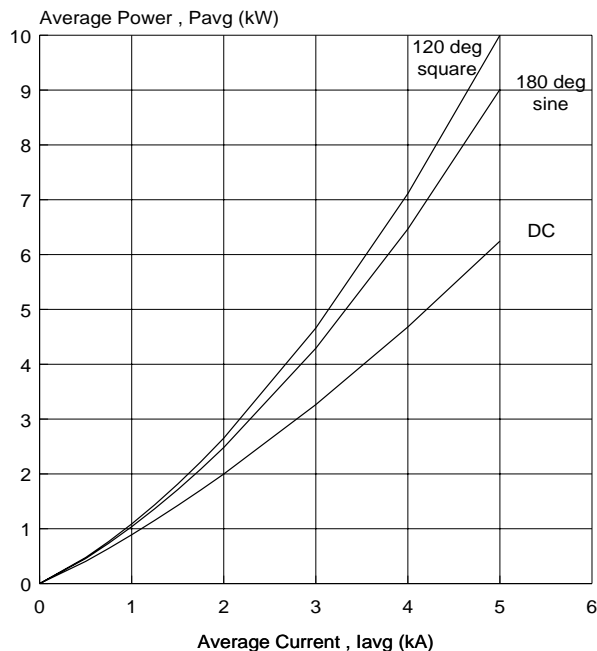

AVERAGE POWER DISSIPATION

$T_j = 150^\circ\text{C}$   
(watts)

$I_{AV}$ (A)	DC	half sine	$120^\circ$ sq. wave
500	405	457	475
750	641	735	767
1000	891	1038	1088
1250	1152	1364	1437
1500	1424	1713	1815
1750	1706	2086	2220
2000	1998	2841	2652
3000	3264	4291	4660
4000	4680	6467	7112
5000	6245	9010	10012

MAXIMUM PEAK RECOVERY CURRENT

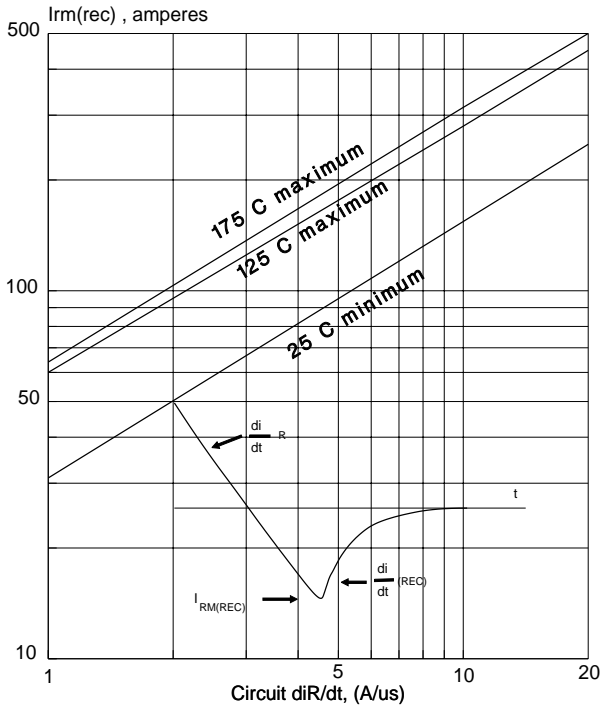

93f:

NON-REPETITIVE  $I_{fsm}$  &  $I_{2t}$  CAPABILITY

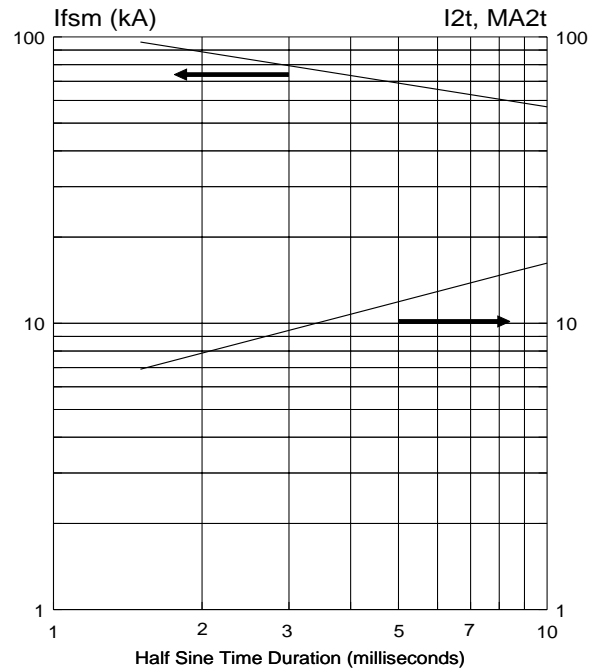

93g:

MOUNTING PRESSPAKS TO HEAT DISSIPATORS

The following instruction is essential for maintaining low, stable thermal and electrical resistances associated with the PRESSPAK to heat dissipator surfaces.

1. INSPECTION OF MATING SURFACES

Check each mating surface for nicks, scratches and surface finish. The PRESSPAK surface has a total indicator reading TIR < .0005 inch and surface finish 32 prior to factory electrical test in pressure fixtures. The dissipator surface should be equally as good. The TIR of a fully tested PRESSPAK may run higher but not exceed 0.001 inch (\*\*) not including some minor nicks and scratches associated with the test fixtures. Any bow created by clamp system at assembly must keep flatness within 0.001 inch. (\*\*) .002 inch for 77mm PRESSPAKS

2. SURFACE DEOXIDATION AND CLEANING

Although plated surfaces are recommended for aluminum and copper heat dissipators, bare surfaces may be used if careful attention to cleaning and treating is assured. Plated surfaces and PRESSPAKS should be lightly sanded with 600 grit paper, then oil or compound applied as recommended. Unplated aluminum surfaces should be vigorously abraded with a fine wire brush or 3M "Scotchbrite" coated with Alcoa EJC #2 compound. The EJC # 2 should be removed and the recommended compound applied.

3. FINAL SURFACE TREATMENT

Apply silicone oil or a very thin layer of grease or compound as indicated below. Rotate the PRESSPAK to properly distribute the applied agent.

- . bare copper - use G322L or LS2037
- . bare aluminum - use EJC #2 or G322L
- . tin plated copper or aluminum
  - preferably reapply DC550 or SF1154
  - alternatively use G623 or G322L
- . nickel plated aluminum - use DC550, G623 or G322L
- . silver plating - not recommended

Recommended silicone oils are SF1154 or DC550 (200 centistoke)

4. MOUNTING

Assemble with specified mounting force applied through a self-leveling swivel connection. The diameter of the swivel should be preferably equal but not smaller than the poleface diameter of the PRESSPAK. Center holes on the top and bottom of the PRESSPAK are for locating and positioning it to identical holes anticipated at the heat dissipator surfaces using 1/8" dia 3/16" roll pins.

NOTES:

Silicone oil DC550 (200 centistoke) is a product of DOW CORNING; clear silicone grease G623, yellow G322L and SF1154(200 centistoke) GE Silicones Waterford NY; EJC# 2 from ALCOA and black LS2037 from ARCO, 7301 Bessemer Ave. Cleveland OH.

Limit maximum joint temperature to:

- 95 C using EJC #2
- 150 C using SF1154, DC550 or G322L

5. APPLIED MOUNTING FORCE

The selection of an appropriate commercially available spring clamping hardware\* should consider establishing and maintaining the specified mounting force over the operating temperature range and operating life of the PRESSPAK. Thus essential ratings such as thermal resistance,  $di/dt$ , surge current and thermal cycling will not be impaired.

Specified forces for this product are as

follows:

- 7000-9000 lbs.
- 31.1 -40.0 kN

\* Consult factory for recommendations or more detailed instructions.