

The SDD303 rectifier diode features a nominal 100mm diameter silicon junction design, manufactured by the proven multi-diffusion process.

SDD303 is designed specifically for high current surges as appropriate for pulse power applications.

**EI-CHARACTERISTICS**  
Process Maximum

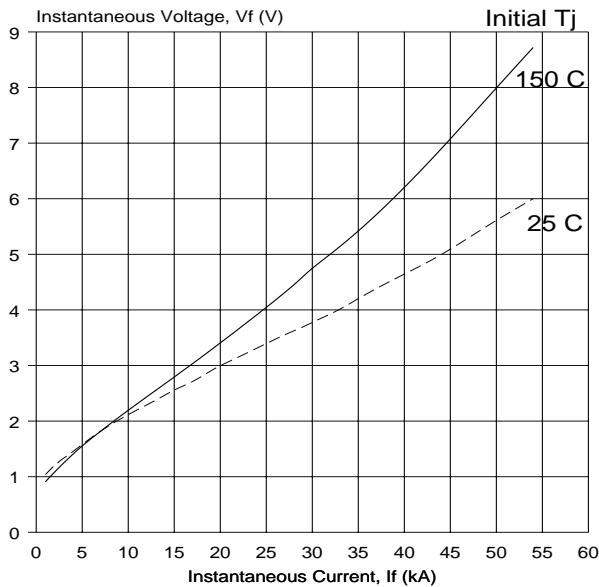

89A:

**THERMAL IMPEDANCE vs. TIME**  
Junction to Case (DC)

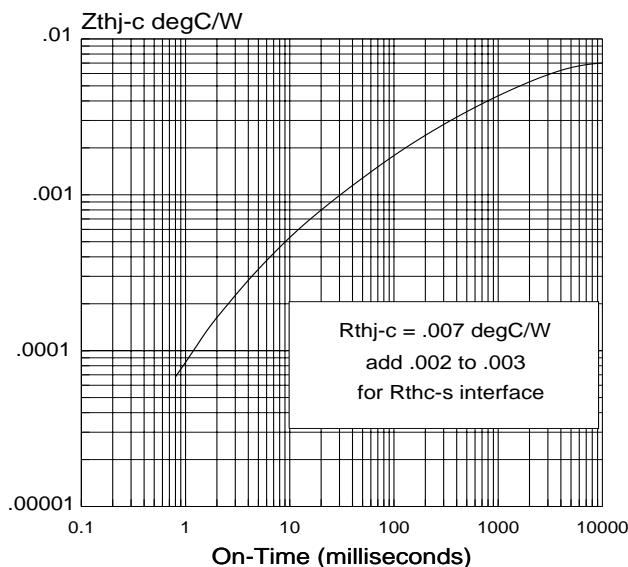

89a:

**PRINCIPAL LIMITS AND RATINGS**

Operating Temperature Range  
-40°C to +150°C

Rep. Peak Reverse Voltage & Current

$$V_{RRM} = 6000 \text{ V}; I_{RRM} = 100 \text{ mA}$$

Non Repetitive Peak Surge Current

$$I_{FSM} (8.3 \text{ ms}, V_R = 0) = 60000 \text{ A}$$

Maximum Peak Recovery Current

$$I_{RM} (150^\circ\text{C}, 140\text{A}/\mu\text{s}) = 1900 \text{ A}$$

(RC snubber required)

Maximum Average Current

$$I_{F(AV)} = 3500\text{A} @ T_{CASE} = 100^\circ\text{C}$$

**MECHANICAL OUTLINE**

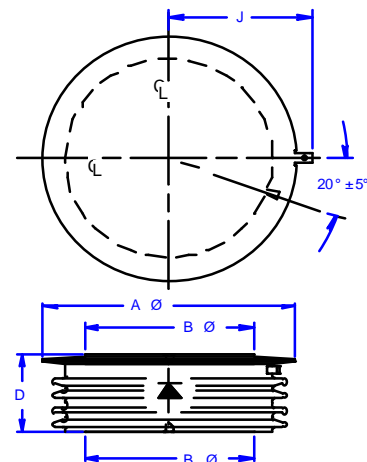

$$A = 5.65 \text{ in (143.5 mm)}$$

$$B = 3.92 \text{ in (99.4 mm)}$$

$$D = 1.45 \text{ in (36.8 mm)}$$

**ELECTRICAL CREEPAGE**

$$1.6 / 1.0 \text{ in}$$

$$40.6 / 25.4 \text{ mm}$$

**CLAMPING FORCE REQUIRED**

$$17000 - 19000 \text{ lb.}$$

$$75 - 85 \text{ kN}$$

LIMITING CHARACTERISTICS AND RATINGS

<u>PARAMETER</u>	<u>SYMBOL</u>	<u>TEST CONDITIONS</u>	<u>MAX. VALUES</u>	<u>UNITS</u>
Average current	$I_{AV}$	half sine $T_c=100^\circ\text{C}$	3500	A
Repetitive peak reverse voltage	$V_{RRM}$	$T_j = 0$ to $+150^\circ\text{C}$ 50/60 Hz	6000	V
Repetitive peak reverse current	$I_{RRM}$	$T_j=150^\circ$ $25^\circ$	100 15	ma
Forward voltage	$V_{FM}$	2kA , $25^\circ\text{C}$ 22kA , $150^\circ\text{C}$ 8ms pulse	1.20 3.75	V
Non-rep peak surge current	$I_{FSM}$	$T_j=150^\circ$ $t_p=8.3\text{ms}$ $t_p=10\text{ms}$	60 55	kA
Peak recovery current	$I_{RM}$	5500A pulse (snubber, 2.3uF/2 ohms) 80A/us $T_j=150^\circ\text{C}$ snappiness "S" approx.= 1	1385A	

Full Cycle Average Power Dissipation  
@  $T_j = 150 \text{ degC}$

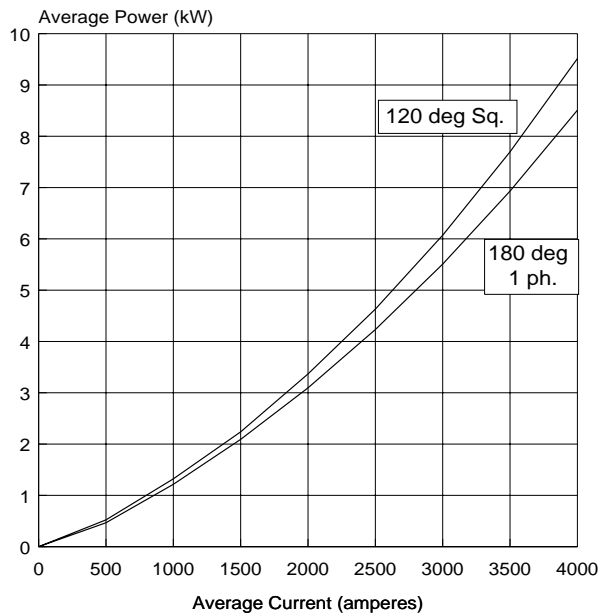

AVERAGE POWER DISSIPATION

@  $T_j = 150^\circ\text{C}$

$I_{AVG}$ (A)	$120^\circ$ sq. wave	half sine
500	523	466
1000	1322	1215
1500	2268	2092
2000	3367	3096
2500	4632	4232
3000	6071	5508
3500	7696	6931
4000	9514	8508