

Type C448 reverse blocking thyristor is suitable for inverter applications. The silicon junction is manufactured by the all-diffused process and utilizes the field-proven, interdigitated amplifying gate structure. It is supplied in an industry accepted disc-type package, ready to mount using commercially available heat dissipators and mechanical clamping hardware.

ON-STATE CHARACTERISTICS

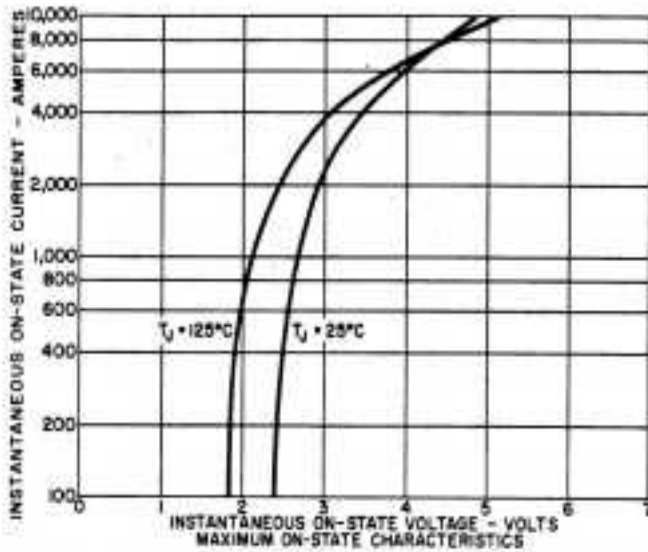

THERMAL IMPEDANCE

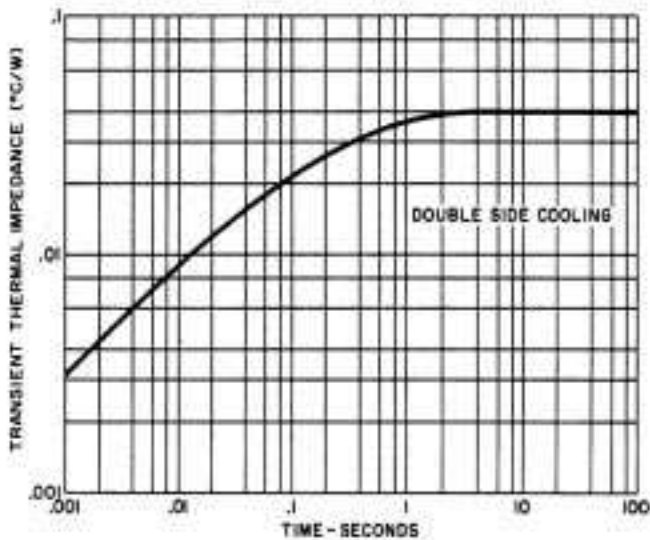

MODEL	V_{DRM} / V_{RRM} 0 to +125°C	@ -40°C
C448PD	1400	1300
C448PB	1200	1100
C448P	1000	900

Gate Drive Requirements:

20 V / 10 ohms / 0.5us risetime

10 - 20 us minimum duration

External Clamping Force

3000 - 3500 lbs.

13.3 - 15.5 kN

MECHANICAL OUTLINE

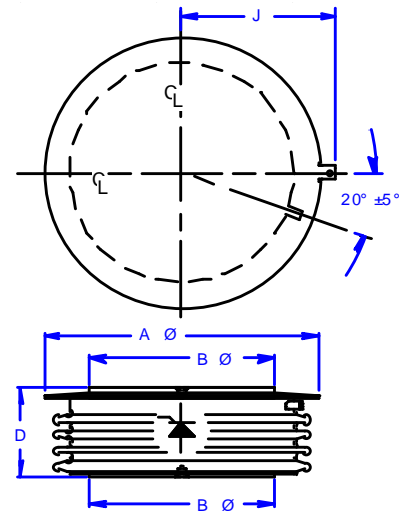

$A \Phi = 2.30$ in (58.0 mm)

$B \Phi = 1.35$ in (34.3 mm)

$D = 1.04$ in (26.4 mm)

LIMITING CHARACTERISTICS

PARAMETER	SYMBOL	TEST CONDITIONS	LIMIT	UNITS
Repetitive peak off-state & reverse voltage	V_{DRM}/V_{RRM}	$T_J = -40$ to $+125^\circ\text{C}$	up to 1400V	volts
Off-state & reverse current	I_{DRM}/I_{RRM}	$T_J = 125^\circ\text{C}$	35	ma
Peak half cycle non-repetitive surge current	I_{TSM}	60Hz (8.3ms) 50Hz (10ms)	10 9.1	kA
For fusing	I^2t	8.3ms	415	kA^2s
On-state voltage	V_{TM}	$I_T = 2000\text{A}$ $t_p = 8.3\text{ms}$ $T_J = 125^\circ\text{C}$	2.45	volts
Critical rate of rise of on-state current	di/dt_{rep}	$V_D = 60\% V_{DRM}$ 60Hz $T_J = 125^\circ\text{C}$ see gate drive	400	A/us
Critical rate of rise of off-state voltage	dv/dt	$V_{DCRIT} = 80\% V_{DRM}$ $T_J = 125^\circ\text{C}$	500	v/us
Reverse recovery charge	Q_{RR}	$I_T = 1000\text{A}, T_J = 125^\circ\text{C}$ @ 10A/us @ 50A/us @ 100 A/us	80 230 320	μC
Circuit commutated turn-off time	t_Q	400V/us to 80% V_{DRM} $V_r = > 50\text{V}$	25	us

