

Type C771 reverse blocking thyristor is suitable for inverter applications. The silicon junction is manufactured by the proven multi-diffusion process and utilizes the exclusive involute gate structure. It is supplied in an industry accepted disc-type package, ready to mount using commercially available heat dissipators and mechanical clamping hardware.

ON-STATE CHARACTERISTIC

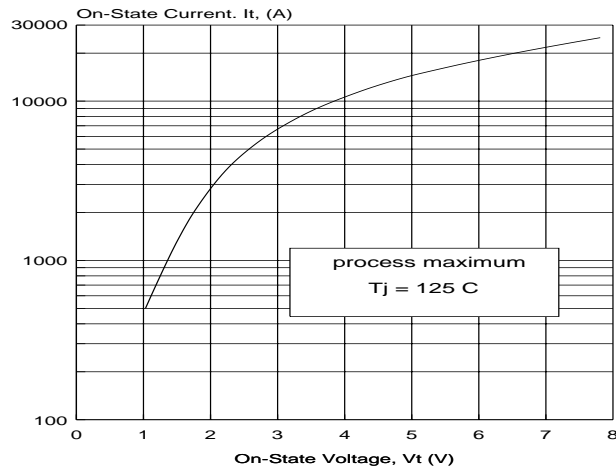

THERMAL IMPEDANCE

THERMAL IMPEDANCE vs. ON-TIME

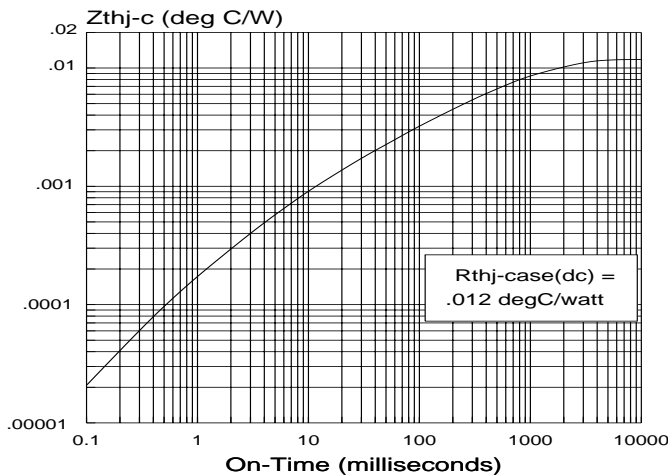

MODEL	V_{DRM} / V_{RRM} 0 to +125°C	@ -40°C
	volts	
C771LS	2800	2700
C771LM	2700	2600
C771LE	2600	2500
C771LD	2500	2400
C771LC	2400	2300
C771LB	2300	2200
C771LA	2200	2100
C771L	2100	2000

Gate Drive Requirements:

20 - 30V / 10 ohms / 0.5us risetime
10 - 20 us minimum duration

External Clamping Force

7000 - 9000 lbs.
31.1 - 40.0 kN

MECHANICAL OUTLINE

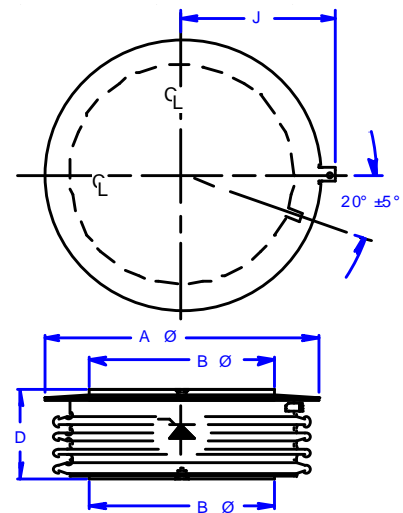

$A \Phi = 4.35$ in (110.5 mm)
 $B \Phi = 2.88$ in (73.2 mm)
 $D = 1.45$ in (36.8 mm)

LIMITING CHARACTERISTICS

PARAMETER	SYMBOL	TEST CONDITIONS	LIMIT	UNITS
Repetitive peak off-state & reverse voltage	V_{DRM}/V_{RRM}	$T_J = -40$ to $+125^\circ\text{C}$	up to 2800V	volts
Off-state & reverse current	I_{DM}/I_{RM}	$T_J = 125^\circ\text{C}$ @ V_{DRM}/V_{RRM} code LE @ $80\% V_{DRM}/V_{RRM}$ codes LM & LS	150	ma
Peak half cycle non-repetitive surge current	I_{TSM}	60Hz (8.3ms) 50Hz (10ms)	32.5 30	kA)
On-state voltage	V_{TM}	$I_T = 2000\text{A}$ $t_p = 8.3\text{ms}$ $T_J = 125^\circ\text{C}$	1.74	volts
Critical rate of rise of on-state current	di/dt_{rep}	$V_D = 60\% V_{DRM}$ 60Hz $T_J = 125^\circ\text{C}$ see gate drive	300	A/us
Critical rate of rise of off-state voltage	dv/dt	$V_{DCRIT} = 80\% V_{DRM}$ $T_J = 125^\circ\text{C}$	500	v/us
Peak recovery current	I_{RM}	$T_J = 125^\circ\text{C}$ @ 10A/us @ 50A/us @ 100 A/us	130 450 750	A
Circuit commutated turn-off time	t_Q	400V/us to $80\% V_{DRM}$ $V_r = > 50\text{V}$	100	us

Non-Repetitive Half-Cycle Peak Surge Current & I2t

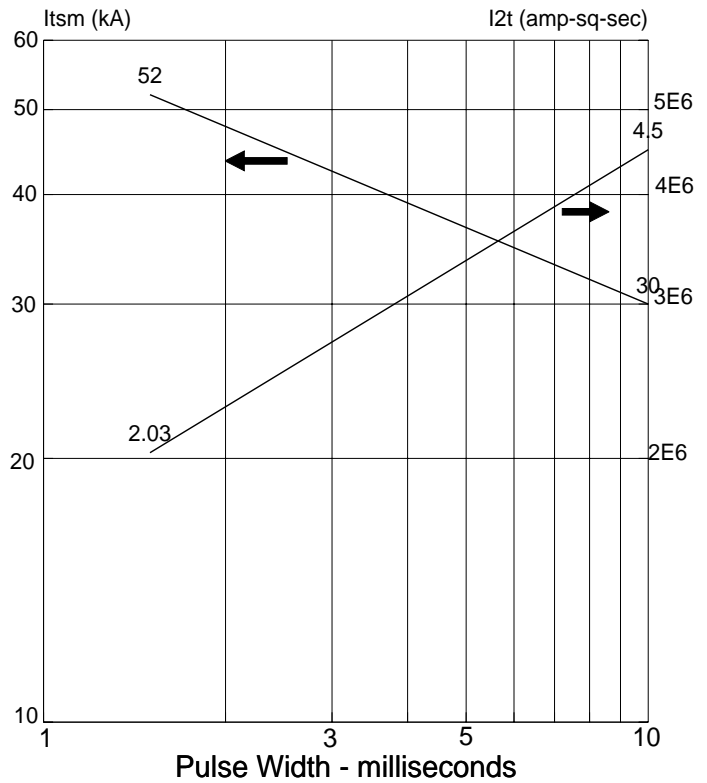

ON-STATE ENERGY Half Sine Pulses

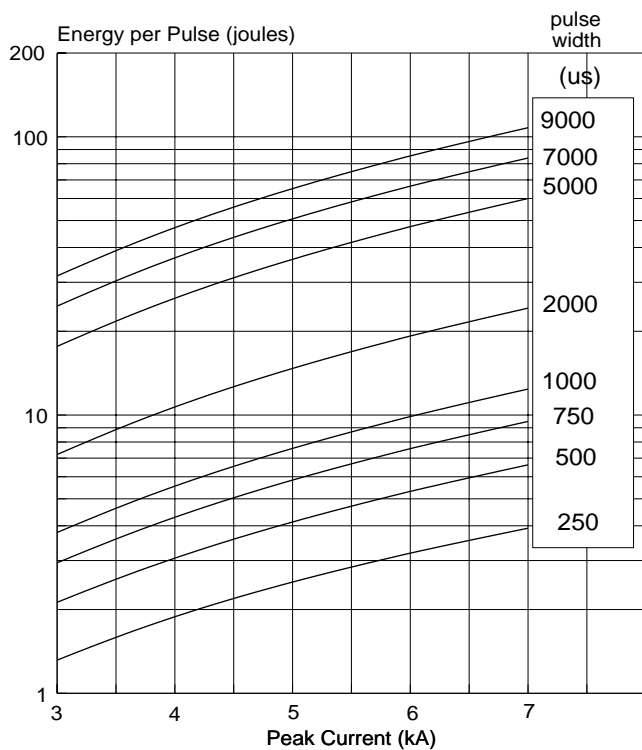

ON-STATE ENERGY Trapezoidal Wave $di/dt = 100\text{ A/us}$

