

SDT200

77mm / 1800V Thyristor

Type SDT200 reverse blocking thyristor, suitable for phase control applications, is especially designed for lowest on-state voltage drop. It is intended for heavy industrial, utility and transportation service.

The silicon junction is manufactured by the proven multi-diffusion process and is supplied in an industry standard disc-type package, ready to mount to natural or forced cooled heat dissipators using commercially available mechanical clamping hardware.

ON-STATE CHARACTERISTIC

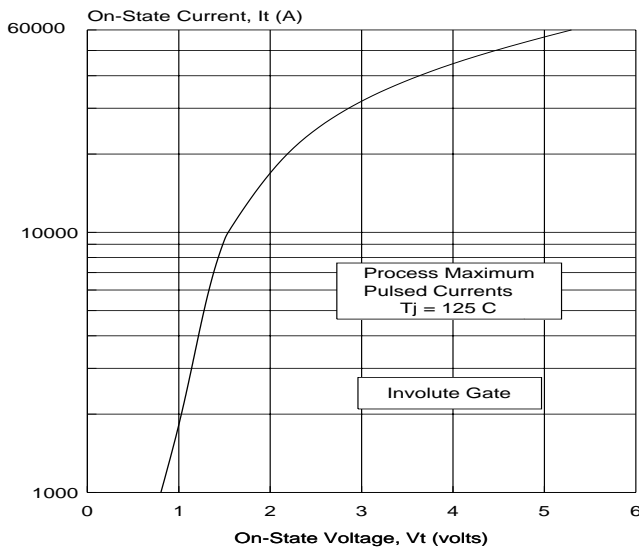

01k:T200ONST

MECHANICAL OUTLINE

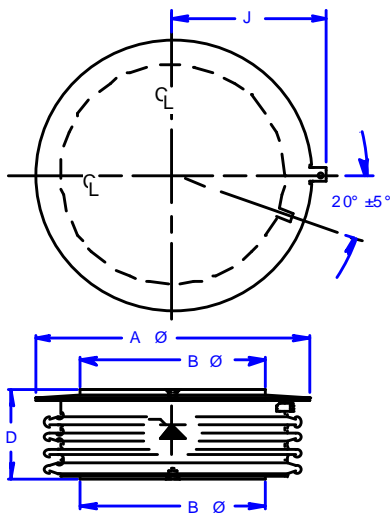

Af = 4.35 in (110.5 mm)
Bf = 2.88 in (73.2 mm)
D = 1.45 in (36.8 mm)

PRINCIPAL RATINGS AND CHARACTERISTICS

OPERATING JUNCTION TEMPERATURE RANGE
-40 to +125°C

- Repetitive peak off-state and reverse voltage V_{DRM} to V_{RRM} 1800V
- Average on-state current @ $T_c = 70^\circ\text{C}$ $I_{T(AV)}$ 3200A
- Peak half cycle surge current for $V_r = 0$ V I_{TSM} 8.3 ms / 10.0 ms
55.0 kA / 51.0 kA
- Maximum peak recovery current, @ 2A/ms I_{RM} 49A
- On-state Voltage @ $I_T = 2000$ A V_{TM} 0.975V
- Critical rate of rise of current @ $V_D = 1500$ V di/dt 125A/us
- Critical rate of rise of off-state voltage dv/dt 1000V/us to $0.8V_{DRM}$
- Turn-off time (typ) t_q 400us

Model No.	V_{DRM} / V_{RRM} -40°C to +125°C	
SDT200TR	1800	1800
SDT200TP	1700	1700
SDT200TM	1600	1600
SDT200TK	1500	1500

GATE DRIVE REQUIREMENTS

- Open circuit voltage / short circuit current 30V / 3A
- Short circuit risetime 0.5us
- Minimum pulse duration 10us

EXTERNALLY REQUIRED CLAMPING FORCE
8000 - 9000 lbs. / 35.6 - 40.0 kN

THERMAL IMPEDANCE vs. ON-TIME

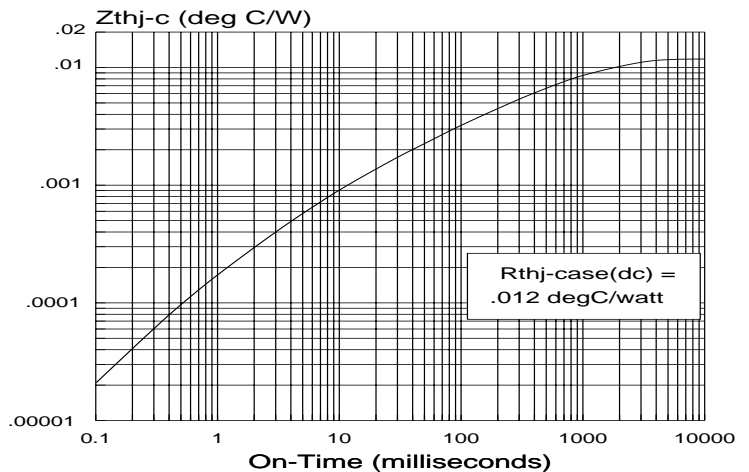

FULL CYCLE AVERAGE POWER

@ T_J = 125 C
60 Hz

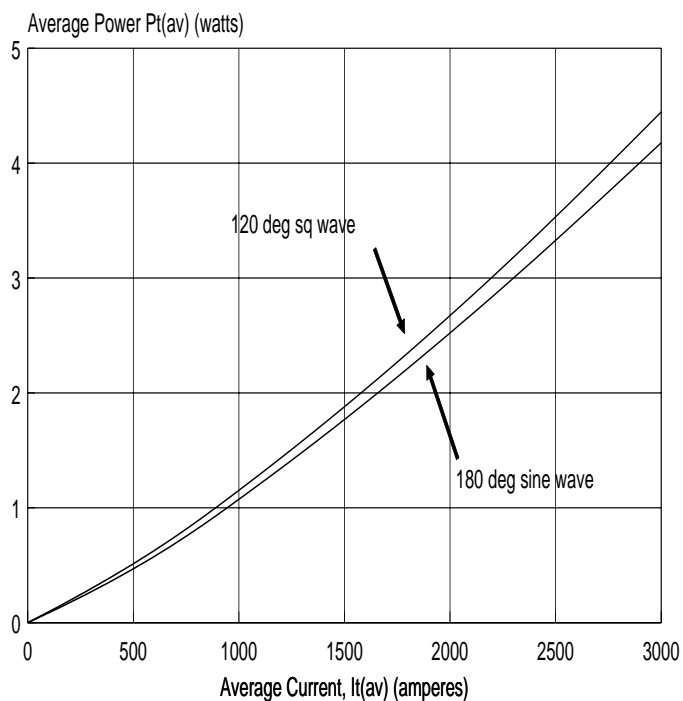

01k:T200PTAV

FULL CYCLE AVERAGE POWER at T_J = 125°C

Full Cycle average	180° half-sine	120° square wave
I _{T(AV)} (A)	P _{T(AV)} (W)	P _{T(AV)} (W)
500	423	471
600	544	599
700	699	730
800	798	865
900	929	1001
1000	1060	1140
1200	1335	1425
1400	1617	1719
1600	1907	2022
1800	2205	2336
2000	2511	2660
2500	3315	3516
3000	4177	4445
3200	4539	4840

Non-Repetitive Sub-cycle Surge Ratings with Commutating di/dt

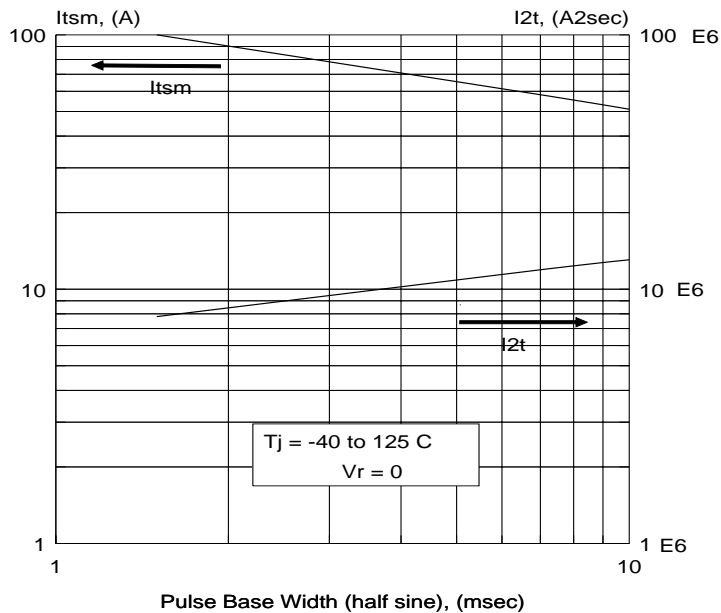

01K:T200ITSM

Peak Recovery Current Relationship with Commutating di/dt

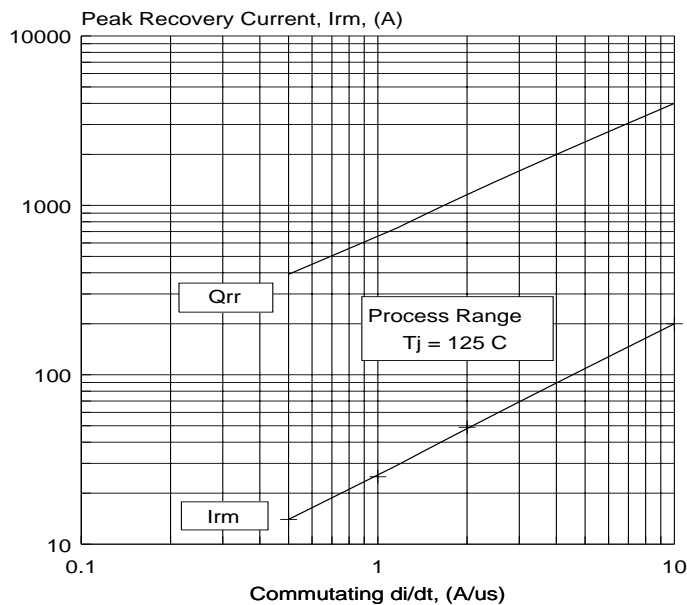

01K:T200REC